

Handwheels and Mechanical Position Indicators

Tangible Quality-
Pure Ergonomics!



In numerous areas of industry, it is necessary to adjust quickly and safely, change settings or regulate values. Also in the era of modern automation, mechanical measuring systems have their permanent place since their economy is convincing and the simple mounting makes retrofitting easy.

Handwheels, Scales ...

Looking hardly distinguishable from conventional handwheels, these precision measuring instruments combine reliable technology and ergonomic design. Whether purely analogue or with additional digital indication, in both cases they provide individual scaling for nearly every gear ratio. The ideal solution for both horizontal and vertical spindles.

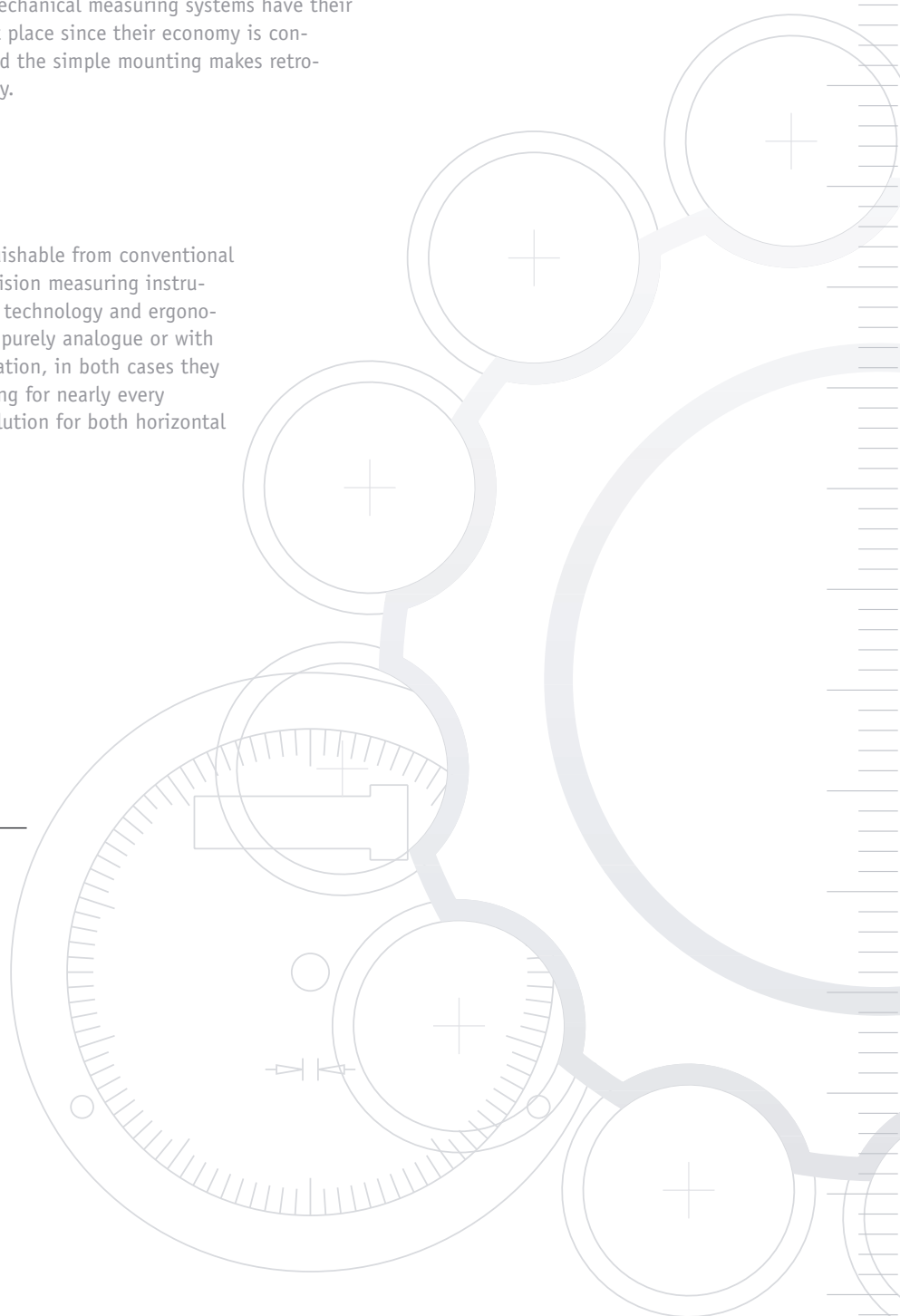
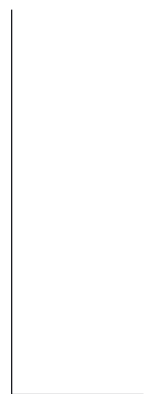

Contents

Position Indicators and Handwheels

4 Product Concept and Operating Principle

5 Handwheels: Indicate and Control

6 The Measure of all Things: Scales, Analogue and Digital Indicators, Specialties ...

7 Position Indicators

9 Handwheels

19 Position Indicator S0 100

20 Handwheel RS0/HS0

22 Accessories for Handwheels

23 Fax Inquiry

23 Fold-out Page with Reference Tables

Timeless, Robust Mechanics

Hand wheels and position indicators from SIKO are prepared for hard times.
with Ergonomical Strengths.

Precision based on the interplay of individual, well thought-out details. Handwheels from SIKO: Highly developed mechanical technology to last for a long time.



Handwheels are mainly used for manual adjustment of axial movements. Therefore, the desire arises to have the adjustments visually displayed. The built-in indicator is the solution. In total, this results for SIKO – above all where the daily usefulness is concerned – in compact, precision mechanical measuring instruments that one can really take hold of with force.

In the interior of the various types, highly precise mechanical measuring units are located to which an indicator mechanism is coupled that

makes the adjusted values directly and analogue readable. The combination of analogue pointer display and digital counting units provides an alternative for still more reading security. The range of the possible applications, even in our era of electronics, is enormous since these indicators also function when the power fails.

For the actual read-out, SIKO provides a range of different scales that can be individualised depending on the respective gear ratio and, naturally, on the requirements of the customer. In order to fulfil as many application criteria as possible, numerous standard gear ratios are selectable for all handwheel types. Nearly every spindle pitch is taken

into consideration.

The design of the handwheels and their built-in position indicators permit the attachment to horizontal spindles exactly the same way as conventional adjustment wheels. A variation of the basic type makes possible the attachment on spindles with any alignment in space. Only the correct mechanical connection between the handwheel and the shaft must be taken into consideration. In total, one can expect a very rugged but advantageous system with regard to the mounting.

For special applications, corrosion-proof, water-tight or oil-filled versions are available. An oil-filled configuration prevents, for example, the clouding over of the glass by moisture that has penetrated into the unit. Anyone requiring a clear view of the position indication under all circumstances finds the solution with this version. The paraffin oil has an additional, positive characteristic: The oil acts as a damping medium which is important for all applications that are subjected to strong vibrations.

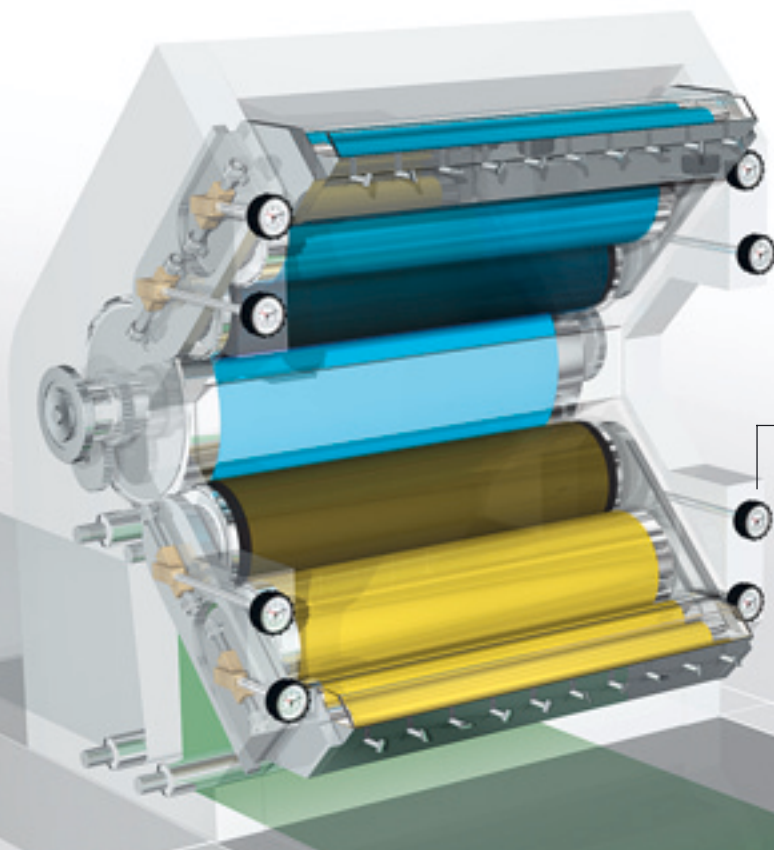

On printing machines, the sensitive adjustment by means of handwheels is efficient and effective. Illustrated here graphically, they regulate the application pressure of the colour carrying cylinder.

Excellent functionality even after a long period: For frequently repeated position and limit settings, manageable, easily readable measuring instruments are essential.

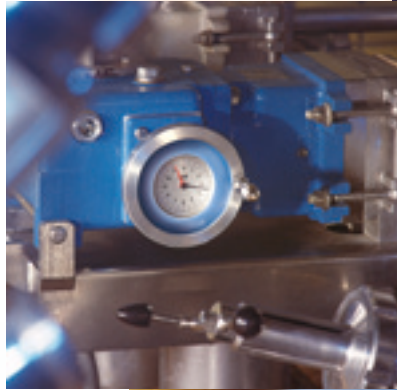

Handwheels and position indicators from SIKO are applied in the most varied applications in industry. As a result of the precise and reliable operating principle, one finds them on printing machines where they regulate the application pressure of the rotating cylinder or in the food industry – as shown here in the picture at the upper left, in a brewery installation to regulate the mixing ratio.



The rugged construction of the handwheels is an important plus point for application in the metal processing industry.

Robust enough to exhibit durability even in the rough working environments of trade and production. The robust operating principle of the position indicators coupled with tangible ergonomics makes the SIKO handwheels extremely reliable.

It is therefore not surprising that these regulating aids can also be found in use in most standard applications amongst the sheet metal and wood industries.

As a result of its very special construction, the handwheel type HKF can be dependably applied in any position.



Scales: The Measure of all Things ...

... regardless if standard or customer-specified.



Standard scales for position indication

As a result of the very different specifications for handwheels, every scale or every divisioning of the position indication must satisfy various requirements. The basis for the indicated values is always formed by the selected gear ratio. This defines the distance that should be travelled for a certain number of revolutions.

The position indicator of the type S can be configured with two pointers whereby one pointer is always moved with a gear ratio. With only one pointer and an assumed gear ratio of 20, a geared pointer moves through a scale range of 360° for 20 hand wheel revolutions, i. e., the complete adjustment distance must be within only one revolution of

Free angle:

In some cases, it may be necessary to include a so-called free angle on the scale. This is dependent on your application and the reductions offered by SIKO.

this pointer. With the selection of a second pointer, it moves 1:1 with the actual handwheel movement.

The position indicator of the type SZ is designed for large measured distances. For this unit, the geared pointer of the indicator type S is replaced with a digital counter. In this manner, it is possible to display absolutely more than one revolution of the reduced pointer. This combination has proven itself above all in applications for which a large number of rotations and precise position information are required.

Naturally, standard scales cannot satisfy all requirements. Therefore, SIKO provides special scales that are fabricated according to

customer requirements, for example, to indicate adjustments in both directions that start from a zero value and require a

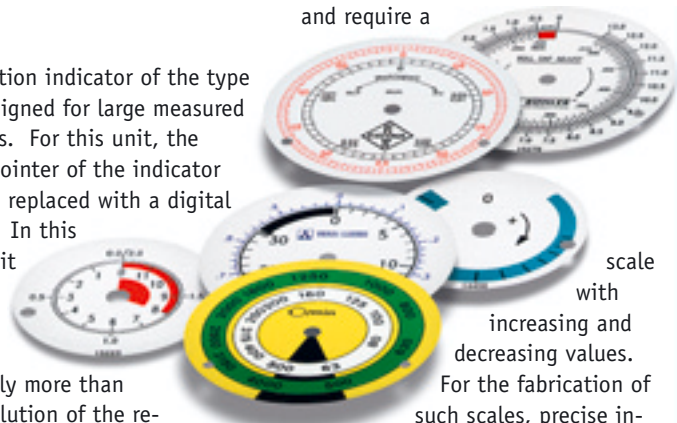

Special scales according to customer's requirements: In most cases a sketch is already adequate.

scale with increasing and decreasing values.

For the fabrication of such scales, precise information in the form of sketches or technical drawings are required. We are glad to comply with special wishes such as division marks, numbers, company logos or requests in regard to colour.

Computation Example* for Type S:

Machine axis, pitch p = 1.75
Measuring range 150 mm

Approach to a Solution:

Number of rotations "U" over the complete measurement range

$$\frac{150 \text{ mm}}{1.75} = 85.71 \text{ U}$$

If the reduction ratio i = 85.71 is not available, select the next possible reduction ratio (> see fold-out page). Assuming the available standard reduction ratio is 100 with free angle, the calculation is then exactly this free angle:
100 revolutions = 360°

Pointer movement:

$$\frac{85.71 \text{ U} \times 360^\circ}{100 \text{ U}} = 308.55^\circ$$

Free angle:
360° - 308.55° = 51.43°

* Example not valid for SZ80/1-

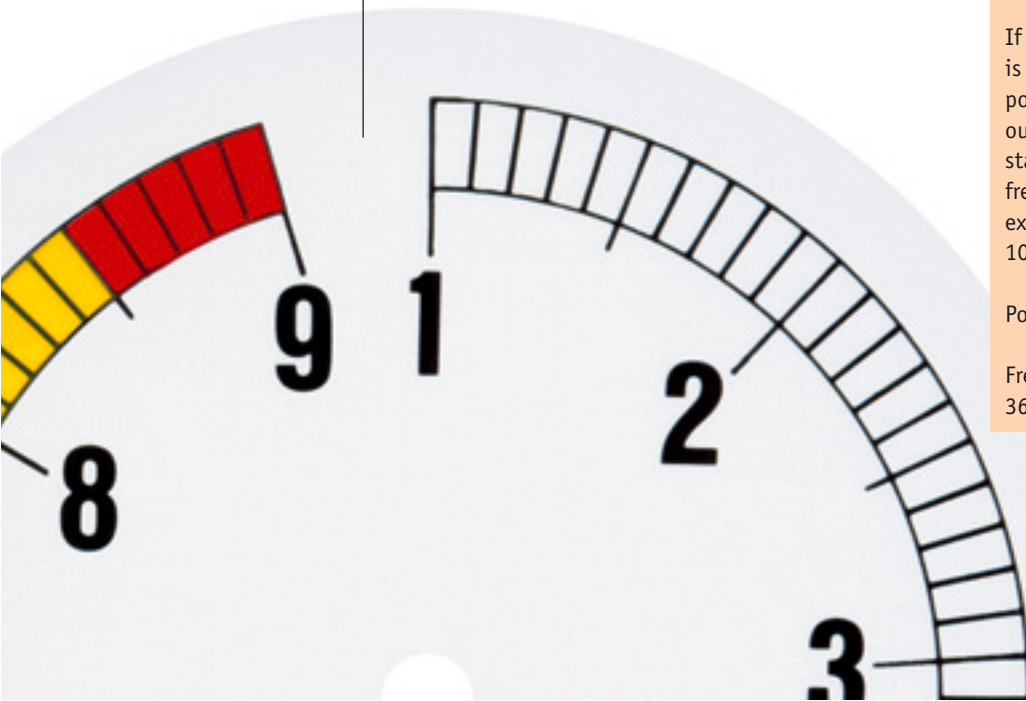

Gravity as the Partner

Why a flick of the wrist is adequate to determine a position...
of Precision Mechanics.

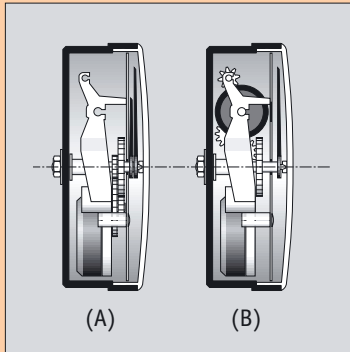

Schematic construction of analogue (A) and digital (B) position indicators. Small weights provide in this example for the vertical reference of the indicator.

The operating principle of the position indicators from SIKO is based on the physical law of gravity. The suspension design in the housing makes possible a double bearing supported pointer shaft that is formed as a suspension axle for a freely swinging weight.

The scale, the gearbox with the required gear ratio and the pointer bushing orient themselves to the weight alignment. If the handwheel is turned, a gear that is firmly attached to the pointer shaft causes the turning motion to be transmitted to the swinging suspended reduction gearbox in the

ratio of 1 : x. This direct connection between handwheel and the bearing supported gearbox makes possible a 100 % accurate value.

For handwheels used on horizontal spindles, this maintenance-free and reliable construction makes possible the exact adjustment and reading even of the finest rotational settings independent of the pitch of the spindle to be measured.

The type HKF makes possible a secure and vibration-free

position acquisition primarily on vertical spindles. For this special SIKO handwheel, a planetary gear-

N	• Dust-tight configuration, standard
P	• Filled with paraffin oil, absorbs vibrations and shocks • is condensation-free
W	• water-tight, without filling

box with additional holder is used whereby the scale for rotation of the handwheel remains in its rest position. The remaining construction is comparable to that of handwheel types for horizontal application.

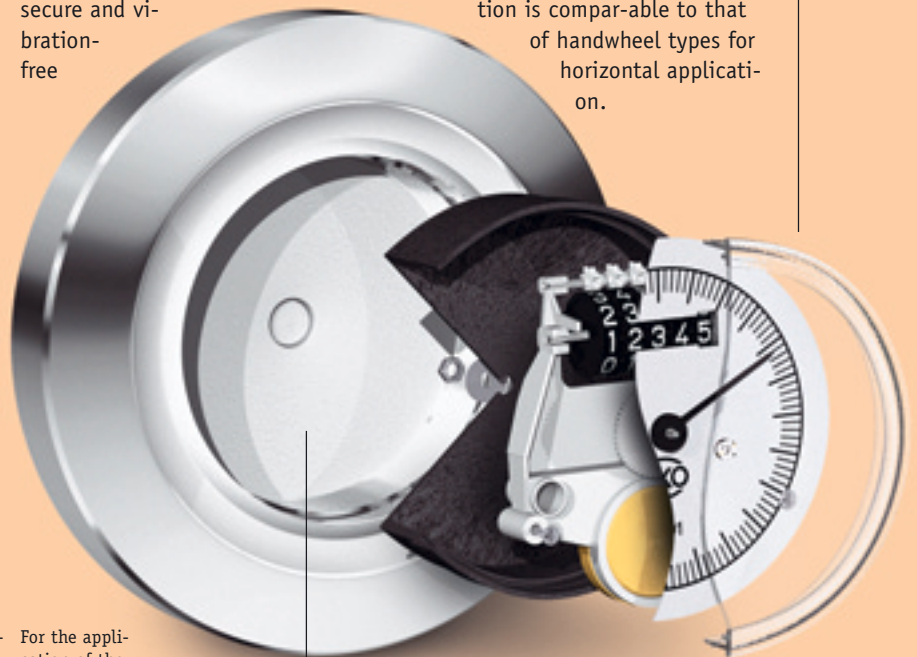

A zero adjustment takes place simply with a screwdriver from the front side of the housing. For the application of the SIKO handwheels without indicator (e. g., purely as cranks), various closing covers are available. Information about the ordering possibilities can be found under the accessories.



Product matrix



Position Indicators S.../1 (General)

This is a new generation of the position indicators that have proven themselves for decades. Improved technology and higher stability as well as an attractive design are only some of the qualities of this new indicator.

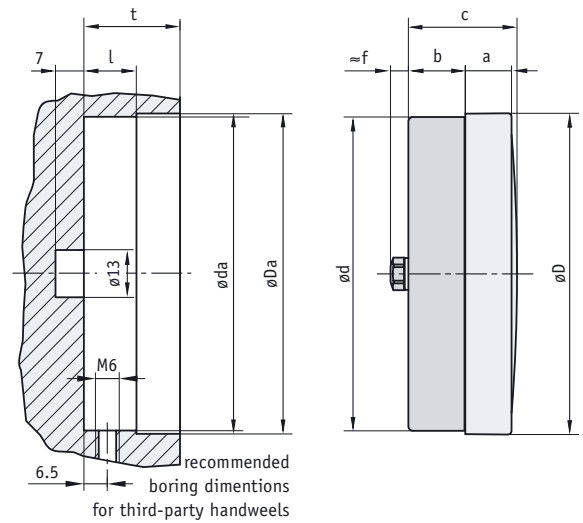

Features:

- high stability as a result of a doubly supported pointer shaft
- very solid fiber-glass reinforced plastic housing
- special scales also for small number of parts
- large selection of gear ratios

Option:

oil-filled (protection against vibration and shock)

recommended installation dimensions for the position indicator

Type	øD	ød	a	b	c	f
S50/1	51.7	50.2	11.5	14.7	29.2	4.2
S70/1	66.8	65.0	11.3	16.2	28.5	4.5
S80/1	86.8	84.8	12.7	15.6	29.8	4.5
S120/1	124.2	122.6	12.7	15.6	29.8	4.5

recommended boring dimensions

Type	øDa	øda	l	t
S50/1	52.0 ^{+0.2}	50.5 ^{+0.1}	12.2 ^{-0.2}	24.0
S70/1	67.2 ^{+0.2}	65.4 ^{+0.1}	14.0 ^{±0.1}	24.0
S80/1	87.0 ^{+0.2}	85.2 ^{+0.1}	14.5 ^{±0.1}	26.5
S120/1	124.6 ^{+0.2}	123.0 ^{+0.3}	14.5 ^{±0.1}	26.5

Feature	Ordering data	S50/1	S70/1	S80/1	S120/1	Technical data	Additional information
Type	N P W	A	•	•	•	dust-tight oil-filled water-tight	standard
Gear ratio		B	•	•	•	see fold-out page	
Rotation direction = increas. values	I E	C	•	•	•	clockwise counter-clockwise	
Pointer	1 2	D	•	•	•	pointer continuously geared one pointer geared	and one pointer runs 1:1
Cover glass	S A	E		•		plastic plastic, acetone-resistant	standard
Zero reset	ON MN	F		•	•	without zero reset with zero reset	standard
Scale	N VK	G	•	•	•	normal scale special scale	standard, related to the gear ratio customer-specified, for first fabrication, no VK
Scale printing	C1 C2 C3	H	•	•	•	single-colour two-colour three-colour	standard
Housing material						plastic, reinforced	
Weight N and W versions			0.1	0.1	0.1	0.2	in kg
Weight P version			0.1	0.2	0.2	0.4	in kg

Your ordering data: S ... /1 - [A] - [B] - [C] - [D] - [E] - [F] - [G] - [H]

Position Indicator SZ80/1

This new generation of the position indicator with counter for unambiguous measured value indication provides like the SIKO Series S.../1, for example, an improved technology and higher stability as well as a modern, attractive design.

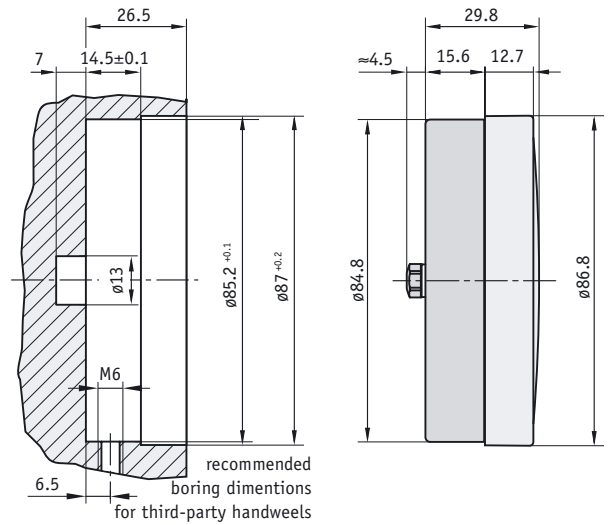

Features:

- high stability as a result of doubly supported pointer shaft
- very solid fiber-glass reinforced plastic housing
- unambiguous measured value display thanks to digital counter

Option:

- oil-filled (protection against vibration and shock)
- various special indication values available

recommended installation dimensions for the position indicator

Type	øD	ød	a	b	c	f
S50/1	51.7	50.2	11.5	14.7	29.2	4.2
S70/1	66.8	65.0	11.3	16.2	28.5	4.5
S80/1	86.8	84.8	12.7	15.6	29.8	4.5
S120/1	124.2	122.6	12.7	15.6	29.8	4.5

recommended boring dimensions

Type	øDa	øda	l	t
S50/1	52.0 ^{+0.2}	50.5 ^{+0.1}	12.2 ^{-0.2}	24.0
S70/1	67.2 ^{+0.2}	65.4 ^{+0.1}	14.0 ^{±0.1}	24.0
S80/1	87.0 ^{+0.2}	85.2 ^{+0.1}	14.5 ^{±0.1}	26.5
S120/1	124.6 ^{+0.2}	123.0 ^{+0.3}	14.5 ^{±0.1}	26.5

Feature	Ordering data	Technical data	Additional information
Type	N P	A dust-tight oil-filled	standard
Display after 1 revolution	B	see fold-out page "gear ratios"	e.g. 00010
Comma positions	0 or 1,2,3,4 C	e.g. 1 = 0.0 or 2 = 0.00	
Rotation direction = increas. values	I E D	clockwise counter-clockwise	
Pointer	1 OZ E	pointer running 1:1 without pointer	
Cover glass	S A F	plastic plastic, acetone-resistant	standard
Scale	N VK G	normal scale special scale	standard , related to display after 1 revolution customer-specified, for initial fabrication, no VK
Scale printing	C1 C2 C3 H	single-colour two-colour three-colour	standard
Housing material		plastic, reinforced	
Weight N version		0.2 kg	
Weight P version		0.3 kg	

Your ordering data: SZ80/1 - - - - - - - -

Handwheel KHB...

This favourably priced plastic handwheel with robust aluminium hub is available in various sizes.

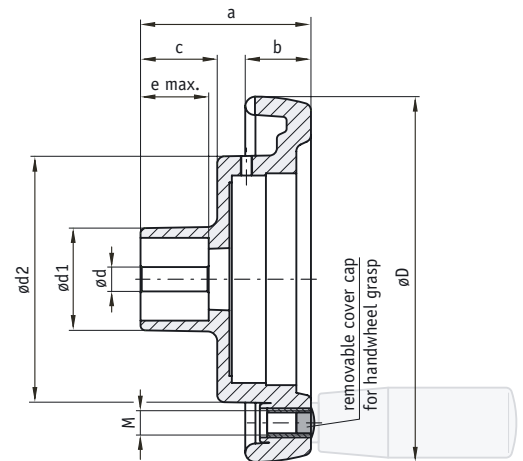

Features:

- various sizes
- aluminium hub for high stability and easy shaft mounting

Type	øD	ødv	ødx	ødn	ød1	ød2	a	b	c	e	GfG	Suitable for	Weight
KHB 9	87	5.8	16	12	32	63	54	17	21	20	M6	S50/1	0.16 kg
KHB 13	130	6.8	26	20	42	98.2	66	24	28.5	24	M8	S80/1; SZ80/1	0.35 kg
KHB 15	150	6.8	26	20	42	101	70	27	31.5	28	M10	S80/1; SZ80/1	0.43 kg
KHB 20	200	6.8	30	25	46	136	72	32	25	23	M10	S120/1	0.81 kg

dv = d pre-drilled; dx = d max.; dn = d max. with key groove; GfG = thread for handle

Feature	Ordering data	Technical data	Additional information
Handwheel	KHB... A	see table above	
Bore ød	d pre-dr. ... B	pre-drilled, see table above, value ødv d max. in mm steps (H7)	standard see table above (smallest bore corresponding to d pre-dr.)
Key groove	OP JS9 C	without key groove transition fit	standard acc. to DIN 6885 T1
Pin hole (only without key groove)	OS No. x ø/f D	without pin hole see fold-out page	standard no. of pinholes x diameter / dimension f e.g. 2x3.8/12
Hub thread	ONG No. x ø/f E	without hub thread see fold-out page	standard no. of hub threads x diameter / dimension f e.g. 2xM4/12
Turned-down hub	OAN 20x15 F	without turned-down hub see fold-out page	Standard nur KHB9
Position indicator mounted (*)	PM PS G	position indicator mounted position indicator separate	standard
Material		handwheel: plastic, black	hub: aluminium

* separate ordering of a position indicator necessary! (> see pages 9/10)

Your ordering data: - - - - - - -

Handwheel HK.../HKL...

A classic made of cast aluminium that can be utilised very flexibly as a result of a series of selectable diameters.

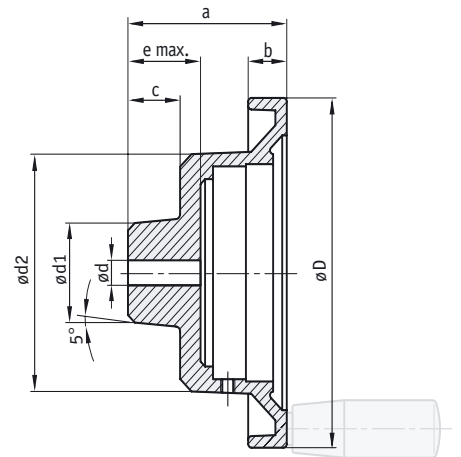

Features:

- robust design

Option:

- various hub options
- surface plastic coated

Type	ØD	Ødv	Ødx	Ød1	Ød2	a	b	c	e	l2	GfG	Suitable for	Weight
HK 8	80	5.8	16	26	60	52	14	20	21	43	M6	S50/1	0.2 kg
HK 10	100	5.8	16	26	60	55	15	20	23	43	M6	S50/1	0.4 kg
HK 12	120	6.8	25	40	95	64	15	23	30	43	M6	S80/1; SZ80/1	0.5 kg
HK 14	140	7.8	25	40	95	70	17	23	30	65	M8	S80/1; SZ80/1	0.6 kg
HK 16	160	7.8	25	40	95	70	20	23	24	65	M8*	S80/1; SZ80/1	0.7 kg
HK 20	200	7.8	30	45	95	75	22	25	32	80	M10*	S80/1; SZ80/1	0.8 kg
HKL 20	200	7.8	30	45	132	75	22	25	31	80	M10*	S120/1	0.9 kg

dv = d pre-drilled; dx = d max.; GfG = thread for handle

Feature	Ordering data	Technical data	Additional information
Handwheel	HK...	see table above	
	HKL...	see table above	
Surface	B	without varnish	standard
	C	plastic-coated, hammer finish, light grey	
	CS	plastic-coated, black RAL9005 half-matt	
Handle bore	OG	without handle bore	
	...	with handle bore or thread	see table above, value GfG (or also 6.4 possible)
Bore Ød	d pre-dr.	pre-drilled, see table above, value Ødv	standard
	...	d max. in mm steps (H7)	see table above (smallest bore corresponding to d pre-dr.)
Key groove	OP	without key groove	standard
	JS9	transition fit	acc. to DIN 6885 T1
	P9	press fit	acc. to DIN 6885 T1
Pin hole (only without key groove)	OS	without pin hole	standard
	No. x Ø/f	see fold-out page	no. of pinholes x diameter/dimension f e.g. 2x3.8/12
or			
Hub thread	ONG	without hub thread	standard
	No x Ø/f	see fold-out page	no. of hub threads x diameter/dimension f e.g. 2xM4/12
Turned-down hub	OAN	without turned-down hub	standard
	d1 (f7)xL	see fold-out page	dependent on d max.
Position indicator mounted (*)	PM	position indicator mounted	standard
	PS	position indicator separate	
Material		aluminium	

* separate ordering of a position indicator necessary! (> see pages 9/10)

Your ordering data: - - - - - - - - -

Handwheel HS.../HSL...

Made of cast aluminium and very robust as a result. The large number of sizes is a special characteristic of this handwheel type.

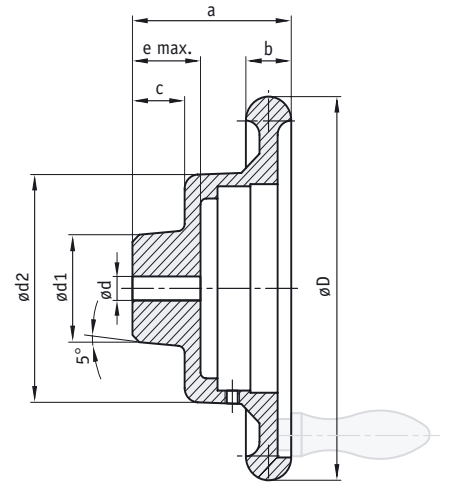

Features:

- robust design

Option:

- various hub options
- surface plastic coated

Type	øD	ødv	ødx	ød1	ød2	a	b	c	e	l2	GfG	Suitable for	Weight
HS 8	80	5.8	16	26	60	55	15	18	20	49	M6	S50/1	0.2 kg
HS 10	100	5.8	16	30	60	55	16	17	21	50	M6	S50/1	0.3 kg
HS 12	120	6.8	25	40	95	70	16.5	23	30	48	M6	S80/1; SZ80/1	0.5 kg
HS 14	140	6.8	20	32	95	70	18	23	29	61.5	M8	S80/1; SZ80/1	0.6 kg
HS 16	160	7.8	30	45	95	70	20	23	30	60.5	M8*	S80/1; SZ80/1	0.7 kg
HS 18	180	7.8	30	45	95	75	22	28	34	75.5	M10*	S80/1; SZ80/1	0.8 kg
HSL 16	160	7.8	30	45	130	65	20	23	28	64	M8	S120/1	0.7 kg
HSL 20	200	7.8	35	55	134	75	22	28	34	75.5	M10	S120/1	0.9 kg
HSL 32	320	9.8	45	80	134	83	28	33	39	75	M12*	S120/1	3.0 kg

* at HS 25 and HSL 32 = M10 for reversing handle
dv = d pre-drilled; dx = d max.; GfG = thread for handle

Feature	Ordering data	Technical data	Additional information
Handwheel	HS... HSL... A	see table above	
Surface	B C	without varnish plastic-coated, hammer finish, light grey others on request	standard
Handle bore	OG ... C	without handle bore with handle bore or thread	see table above, value GfG (or also 6.4 possible)
Bore ød	d pre-dr. ... D	pre-drilled, see table above, value ødv d max. in mm steps (H7)	standard see table above (smallest bore corresponding to d pre-dr.)
Key groove	OP JS9 P9 E	without key groove transition fit press fit	standard acc. to DIN 6885 T1 acc. to DIN 6885 T1
Pin hole (only without key groove)	OS No. x ø/f F	without pin hole see fold-out page	standard no. of pinholes x diameter/dimension f e.g. 2x3.8/12
Hub thread	ONG No x ø/f G	without hub thread see fold-out page	standard no. of hub threads x diameter/dimension f e.g. 2xM4/12
Turned-down hub	OAN d1 (f7)x1 H	without turned-down hub see fold-out page	standard dependent on d max.
Clamp ring	OK MK I	without clamp ring with clamp ring	standard
Position indicator mounted (*)	PM PS K	position indicator mounted position indicator separate	standard
Material		aluminium	

* separate ordering of a position indicator necessary! (> see pages 9/10)

Your ordering data: **HS ...** - **A** - **B** - **C** - **D** - **E** - **F** - **G** - **H** - **I** - **K**

Handwheel HST...

Designed as a compact star grip, this aluminium handwheel is intended to house position indicators.

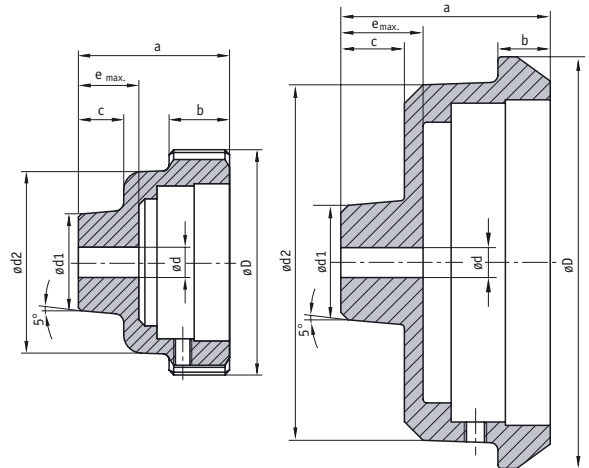

Features:

- robust aluminium design

Option:

- various hub options
- surface plastic coated

Type	øD	ødv	ødx	ød1	ød2	a	b	c	e	Suitable for	Weight
HST 7	78	5.8	20	32	60	50	20	15	20	S50/1	0.2 kg
HST 8	75	5.8	12	20	60	43	10	10	13	S50/1	0.2 kg
HST 11	110	6.8	16	30	95	56	14	17	22	S80/1; SZ80/1	0.5 kg

dv = d pre-drilled; dx = d max.

Feature	Ordering data	Technical data	Additional information
Handwheel	KHK... A	see table above	
Surface	B CS	without varnish plastic-coated, black RAL9005 half-matt others on request	standard not for HST 7
Bore ød	d pre-dr. ...	pre-drilled, see table above, value ødv d max. in mm steps (H7)	standard see table above (smallest bore corresponding to d pre-dr.)
Key groove	OP JS9 P9	without key groove transition fit press fit	standard acc. to DIN 6885 T1 acc. to DIN 6885 T1
Pin hole (only without key groove)	OS No. x ø/f	without pin hole see fold-out page	standard no. of pinholes x diameter/dimension f e.g. 2x3.8/12
Hub thread	ONG No. x ø/f	without hub thread see fold-out page	standard no. of hub threads x diameter/dimension f e.g. 2xM4/12
Turned-down hub	OAN d1 (f7)xl	without turned-down hub see fold-out page	standard dependent on d max.
Position indicator mounted (*)	PM PS	position indicator mounted position indicator separate	standard
Material		aluminium	

* separate ordering of a position indicator necessary! (> see pages 9/10)

Your ordering data: HST... - **A** - **B** - **C** - **D** - **E** - **F** - **G** - **H**

Handwheel HG...

An economically priced plastic handwheel and compact turning handle for housing position indicators.

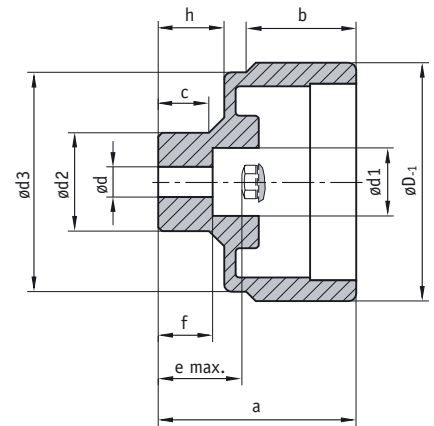

Features:

- fiber-glass reinforced plastic

Option:

- various hub options
- version with rounded edges for the prevention of dirt/particle ingress

Typ	Hub material	øD	ødv	ød	ød1	ød2	ød3	a	b	c	e	f	h	Suitable for	Weight
HG 5	Plastic	63	-	06-12 ^{H9}	13	21	58	49	28.9	14.3	19.2	17.3	14.3	S50/1	0.1 kg
	Metal	63	5.8	06-16 ^{H7}	18	26	58	52	28.9	13.3	22.2	14.3	17.3	S50/1	0.1 kg
HG 10	Plastic	98	-	06-16 ^{H9}	16	30	93	56	31.5	18.7	22.8	20.7	18.7	S80/1; SZ80/1	0.2 kg
	Metal	98	5.8	06-16 ^{H7}	25.5	35	93	59	31.5	18.2	25.8	18	21.7	S80/1; SZ80/1	0.2 kg

dv = d pre-drilled

Feature	Ordering data	Technical data	Additional information
Handwheel	HG... A	see table above	
Hub material	A K VA	aluminium plastic reinforced Nirosta	standard
Bore ød	d pre-dr. ... C	pre-drilled, see table above, value ødv d max. in mm steps (H7)	standard see table above (smallest bore corresponding to d pre-dr.)
Key groove	OP JS9 P9 D	without key groove transition fit ** press fit **	standard acc. to DIN 6885 T1 acc. to DIN 6885 T1
Pin hole (only without key groove)	OS No. x ø/f E	without pin hole see fold-out page	standard no. of pinholes x diameter/dimension f e.g. 2x3.8/12
Hub thread	ONG No x ø/f F	without hub thread see fold-out page **	standard no. of hub threads x diameter/dimension f e.g. 2xM4/12
Turned-down hub	OAN d1 (f7)xl G	without turned-down hub see fold-out page **	standard dependent on d max.
Position indicator mounted (*)	PM PS H	position indicator mounted position indicator separate	standard
Material		handwheel: plastic	hub: aluminium (option: Nirosta, plastic)
Colour		black	

* separate ordering of a position indicator necessary! (> see pages 9/10), ** only with hub material "Metal"

Your ordering data: - - - - - - - -

Handwheel HR...

A very high quality, knurled aluminium handwheel for housing SIKO position indicators.

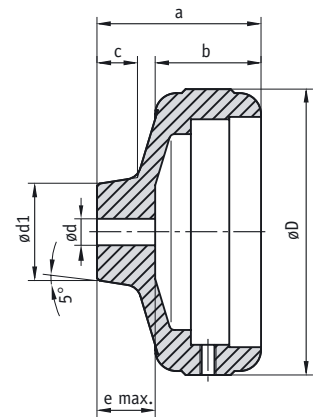

Features:

- compact design
- robust configuration made of aluminium
- surface plastic coated, anodised or blank

Option:

various hub options

Type	øD	ødv	ødx	ød1	a	b	c	e	Suitable for	Weight
HR 6	65	5.8	16*	30	50	35	15	20	S50/1	0.3 kg
HR 11	108	6.8	20	36	62	40	15	22	S80/1; SZ80/1	0.5 kg

*ø17-20 without groove, pin hole, turned-down hub possible
dv = d pre-drilled; dx = d max.

Feature	Ordering data	Technical data	Additional information
Handwheel	HR... A	see table above	
Surface	B ES EF	B without varnish black anodised naturally anodised others on request	standard
Bore ød	d pre-dr. ... C	pre-drilled, see table above, value ødv d max. in mm steps (H7)	standard see table above (smallest bore corresponding to d pre-dr.)
Key groove	OP JS9 P9 D	without key groove transition fit press fit	standard acc. to DIN 6885 T1 acc. to DIN 6885 T1
Pin hole (only without key groove)	OS No. x ø/f E	without pin hole see fold-out page	standard no. of pinholes x diameter/dimension f e.g. 2x3.8/10
Hub thread	ONG No x ø/f F	without hub thread see fold-out page	standard no. of hub threads x diameter/dimension f e.g. 2xM4/10
Turned-down hub	OAN d1 (f7)xl G	without turned-down hub see fold-out page	standard dependent on d max.
Position indicator mounted (*)	PM PS H	position indicator mounted position indicator separate	standard
Material		aluminium	

* separate ordering of a position indicator necessary! (> see pages 9/10)

Your ordering data: - - - - - - - -

Handwheel HR5

Compact handwheel made of aluminium with permanently fixed position indicator.

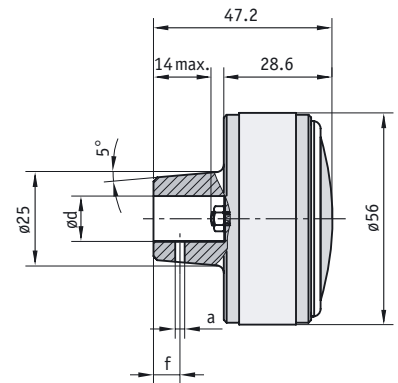

Features:

- surface anodised or blank
- various gear ratios and special scales

Option:

- various hub options

Type	ød	ødx
HR5	8	12

dx = d max.

Feature	Ordering data	Technical data	Additional information
Bore ød	d ...	A see table above, value ød - ødx d max. in mm steps (H7)	standard see table above
Surface	B ES EF	B without varnish black anodised naturally anodised	standard
Gear ratio	•••	C see fold-out page for values	
Rotation direction	I E	D clockwise counter-clockwise	
Pointer	1 2	E pointer continuously geared one pointer geared and one pointer runs 1:1	
Pin hole	OS 1x2.5/7	F without pin hole see fold-out page	standard no. of pinholes x diameter/dimension f
Hub thread	ONG 1xM6/8 2xM6/8	G without hub thread see fold-out page see fold-out page	standard no. of hub threads x diameter/dimension f no. of hub threads x diameter/dimension f
Scale	N VK	H normal scale special scale	standard , referenced to the gear ratio customer-specified, for 1st fabrication, no VK
Skalenbedruckung	C1 C2 C3	I einfarbig zweifarbig dreifarbig	Standard
Material		aluminium	
Weight		0.1 kg	

Your ordering data: - - - - - - - - -

Handwheel HKS...

Extremely operator-friendly and very robust spoke handwheel made of cast aluminium.

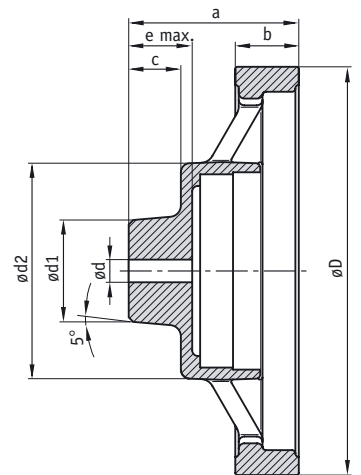

Features:

- robust design
- bored for S80/1 or SZ80/1

Option:

- various hub options
- surface plastic coated

Type	øD	ødv	ødx	ød1	ød2	a	b	c	e	Suitable for	Weight
HKS 18	180	7.8	30	45	95	75	28	23	25	S80/1; SZ80/1	0.9 kg

dv = d pre-drilled; dx = d max.

Feature	Ordering data	Technical data	Additional information
Handwheel HKS...	A	see table above	
Surface	B C	without varnish plastic coat, hammer finish, light grey	standard
Bore ød	d pre-dr. ...	pre-drilled, see table above, value ødv d max. in mm steps (H7)	standard see table above (smallest bore corresponding to d pre-dr.)
Key groove	OP JS9 P9	without key groove transition fit press fit	standard acc. to DIN 6885 T1 acc. to DIN 6885 T1
Pin hole (only without key groove)	OS No. x ø/f	without pin hole see fold-out page	standard no. of pinholes x diameter/dimension f e.g. 2x3.8/12
Hub thread	ONG No. x ø/f	without hub thread see fold-out page	standard no. of hub threads x diameter/dimension f e.g. 2xM4/12
Turned-down hub	OAN d1 (f7)xl	without turned-down hub see fold-out page	standard dependent on d max.
Position indicator mounted (*)	PM PS	position indicator mounted position indicator separate	standard
Material		aluminium	

* separate ordering of a position indicator necessary! (> see pages 9/10)

Your ordering data: - - - - - - - -

Handwheel HKF...

With its built-in position indicator, this handwheel of aluminium is designed for mounting on spindles of any orientation – and therefore suitable even for critical installation positions.

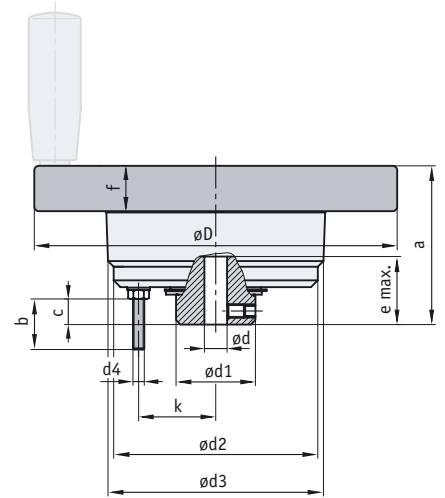

Features:

- various sizes
- various gear ratios

Option:

- various hub options
- easy mounting

	øD	ødv	ødx	ød1	ød2	ød3	d4	a	b	c	e	f	k	GfG	Weight
HKF12	120	6.8	20	35	90	95	M5	64	22.3	13.3	32	15	34	M6	1.0 kg
HKF16	160	7.8	20	35	90	95	M5	70	22.3	11.3	30	20	34	M8*	1.1 kg

dv = d pre-drilled; dx = d max.; GfG = thread for handle

Feature	Ordering data	Technical data	Additional information
Handwheel	HKF... A	see table above	
Surface	C KS	B plastic coated, hammer finish, light-grey plastic coated, black RAL9005 half-matt	standard
Handle bore	OG ...	C without handle bore with handle bore or handle thread	see table above, value GfG (or also 6.4 possible)
Bore ød	d pre-dr. ...	D pre-drilled, see table above, value ødv d max. in mm steps (H7)	standard see table above (smallest bore corresponding to d pre-dr.)
Key groove	OP JS9 P9	E without key groove transition fit press fit	standard acc. to DIN 6885 T1 acc. to DIN 6885 T1
Clamp ring	OK MK	F without clamp ring with clamp ring	standard
Gear ratio	... G	value see fold-out page	
Rotational direction	I E	H clockwise counter-clockwise	
Pointer	1 2	I pointer continuously geared one pointer geared and one pointer runs 1:1	
Zero reset	ON MN	K without with	standard
Scale	N VK	L normal scale special scale	standard , related to gear ratio customer specified, for 1st fabrication, no VK
Material		aluminium	

Your ordering data: **HKF...** - **A** - **B** - **C** - **D** - **E** - **F** - **G** - **H** - **I** - **K** - **L**

Position Indicator SO 100

For all applications where front position indicators would not be visible, this handwheel / indicator combination with drum scale provides the solution. By means of a precision measuring ring, the resolution can be additionally increased.

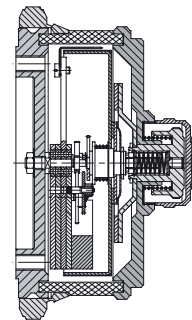
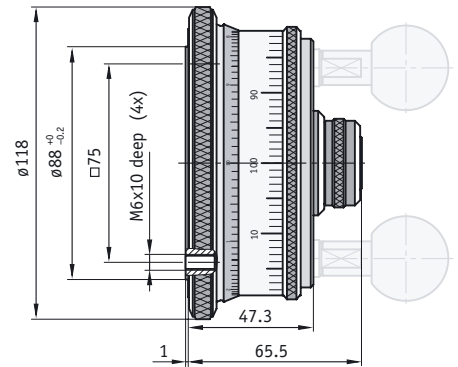

Features:

- for installation to horizontal spindles
- special gear ratios available
- special scales on request
- zero reset

Option:

- ball turning handle

Feature	Ordering data	Technical data	Additional information
Gear ratio	...	A see fold-out page	
Rotation direction = increas. values	I E	B clockwise counter-clockwise	
Scale	N VK	C normal scale special scale	standard customer-specified, for 1st fabrication, no VK
Measuring ring ratio / division	x/y	D x = ratio / y = division	both for the first rotation
Handle	OG 1x 2x	E without handle 1 handle 2 handles	standard
Material		aluminium	
Colour		black	
Weight		0.9 kg	

Your ordering data: SO 100 - - - - -

Handwheel RSO / HSO 16

These handwheels are intended especially for use with the SO 100 position indicator

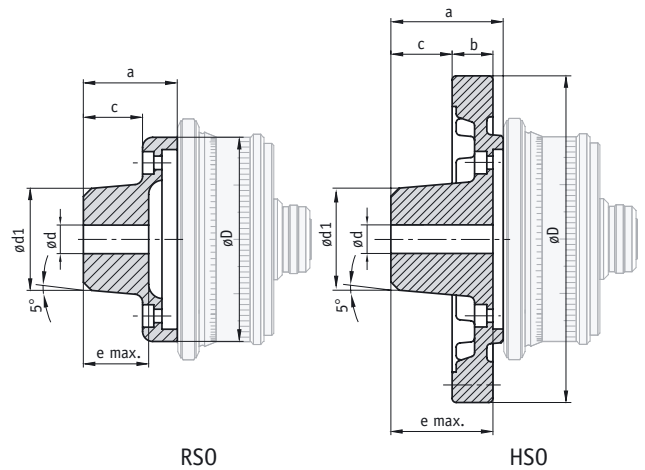

Features:

- robust aluminium design

Option:

- hub adaptation in various versions

Type	øD	ødv	ødx	ød1	a	b	c	e	GfG	Weight
HSO 16	160	7.8	35	50	55	20	30	50	M10	1.6 kg
RSO	100	7.8	35	50	46	./.	29	32		0.4 kg

dv = d pred-drilled; dx = d max.; GfG = thread for handle

Feature	Ordering data	HSO	RSO	Technical data	Additional information
Handwheel	HSO 16	•		see table above	
	RSO		•	see table above	
Handle bore	OG	•		without handle bore	
	M10	•		with handle bore or thread	
Bore ød	d pre-dr.	•	•	pre-drilled, s. table above, value ødv	standard
	...	•	•	d max. in mm steps (H7)	s. table above (smallest bore corresponding to d pre-dr.)
Key groove	OP	•	•	without key groove	standard
	JS9	•	•	transition fit	acc. to DIN 6885 T1
	P9	•	•	press fit	acc. to DIN 6885 T1
Pin hole (only without key groove)	OS	•	•	without pin hole	standard
	No. x ø/f	•	•	see fold-out page	no. of pinholes x diameter/dimension f, e.g. 2x3.8/12
Hub thread	ONG	•	•	without hub thread	standard
	No x ø/f			see fold-out page	no. of hub threads x diameter/dimension f, e.g. 2xM4/12
Material		•	•	aluminium	
Colour		•	•	plastic coated, hammer finish, light grey	

Your ordering data: - - - - - -

Accessories

Handwheel handles

Handle types:

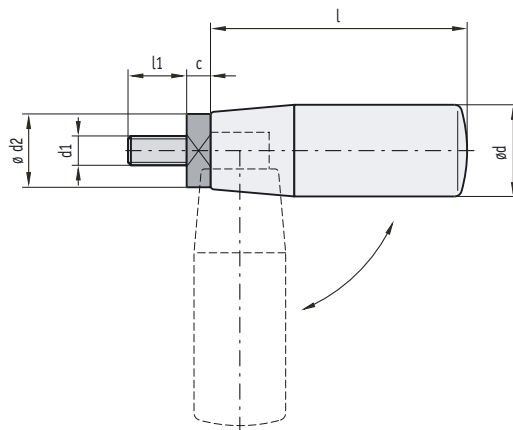
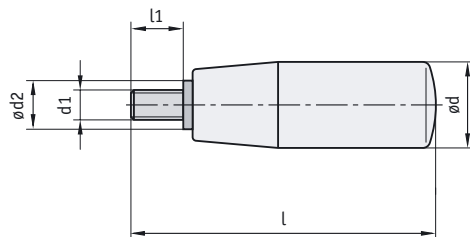
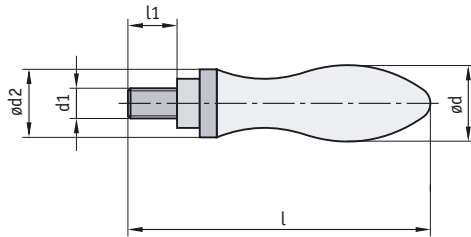

Closing cover:



Ball handle:

Type	Ordering data	d	d1	d2	l	l1
fixed	BGF M6	16	M6	10	61	11
fixed	BGF M8	20	M8	13	77	13
fixed	BGF M10	25	M10	16	94	14
fixed	BGF M12	32	M12	20	121	21
rotatable	BGD M6	16	M6	14	66	11
rotatable	BGD M8	20	M8	18	80	13
rotatable	BGD M10	25	M10	21	97	14
rotatable	BGD M12	32	M12	26	127	21

Order: -

Cylinder handle:

Type	Ordering data	d	d1	d2	l	l1
rotatable	ZGD M6	18	M6	10	55	12
rotatable	ZGD M8	23	M8	13	82	14
rotatable	ZGD M10	26	M10	13	99	16

Order: -

Reversing handle:

Type	Ordering data	d	d1	d2	l	l1	c
rotatable	UG M6	20	M6	15	49	9	5
rotatable	UG M8	25	M8	19	69	10	6
rotatable	UG M10	26	M10	26	82	17	7.5

Order:

Type	Ordering data	Feature
D80	71504	no printing
D80	71505	+/-
D80	71506	-/+
D50	71501	no printing
D50	71502	+/-
D50	71503	-/+

Order:

Fax Inquiry

For immediate information
0 76 61 / 3 94 - 388

To receive more information, simply mark the appropriate item(s) in the list below and fax this page to us.

- Technical advice on SIKO handwheels
- Prospect on digital position indicators
- Visit of a SIKO sales representative
- Pricelist for SIKO products
- Catalogue with brochures on the complete SIKO product range

From:

Name _____

Company _____

Department/Function _____

Street _____

Zip-Code/City _____

Phone _____

Fax _____

eMail _____

Company stamp

**SIKO GmbH**

Weihermattenweg 2
79256 Buchenbach
Germany

Telephone

+49 7661 394-0

Telefax

+49 7661 394-388

E-Mail

info@siko.de

Internet

www.siko.de

Looking for a dealer near
to you?

You can find the complete
addresses of all SIKO product
representatives in the support
section of our website:

www.siko.de

SIKO Products Inc.

P.O. Box 279
Dexter, MI 48130
USA

Telephone

+1 734 42 63 476

Telefax

+1 734 42 63 453

E-Mail

sales@sikoproducts.com

Internet

www.sikoproducts.com

SIKO Ltd.

Unit 6, Dalton Lane
Codbeck Estate, Dalton
Thirsk, North Yorkshire
YO7 3HR
United Kingdom

Telephone

+44 1845 578845

Telefax

+44 1845 577781

E-Mail

sales@siko-uk.com

Internet

www.siko-uk.com

SIKO Italia S.r.l.

Via Borromeo, 4
I-20017 Rho MI
Italy

Telephone

+39 02 9390 6329

Telefax

+39 02 93469532

E-Mail

info@siko-italia.com

Internet

www.siko-italia.com

**SIKO Mess- und
Positioniersysteme
GmbH**

Deisrütistrasse 11
8472 Seuzach
Switzerland

Telephone

+41 52 317 46 41

Telefax

+41 52 317 46 42

E-Mail

info@siko-schweiz.ch

Internet

www.siko-schweiz.ch

**SIKO International
Trading (Shanghai)
Co. Ltd.**

Unit A, 26th Floor New
Rainbow Jie Yun Bldg.,
2 Lane 600, Tian Shan
Road, Shanghai/
China 200051

Telephone

+86 21 62 59 47 45

Telefax

+86 21 32 11 04 20

E-Mail

info@siko.cn

Internet

www.siko.cn

■ Hub thread with key groove present

Feature	Ordering date	Designation		
		groove mm	thread	ød
Hub thread				
all hand wheels except	M3/12	4	M3	12
KHB9 and KHB20	M4/12	5	M4	14-16
	M5/12	6	M5	18-22
	M6/12	8	M6	24-30
	M8/12	10	M8	32-35
KHB9	M3/8	4	M3	12
KHB20	M3/10	4	M3	12
KHB20	M4/10	5	M4	14-16
KHB20	M5/10	6	M5	18-24

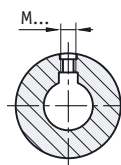

■ Hub thread or pin hole without key groove

Feature	Ordering date	Designation				
		ød >	up to ød	f	øa	b
Pin hole						
all hand wheels except	3.8/12	6	12	12	3.8	-
KHB9 and KHB20	4.8/12	12	25	12	4.8	-
	5.8/12	25	35	12	5.8	-
KHB9	3.8/8	6	12	8	3.8	-
KHB9	4.8/8	12	25	8	4.8	-
KHB20	3.8/10	6	12	10	3.8	-
KHB20	4.8/10	12	25	10	4.8	-
Hub thread						
all hand wheels except	M4/12	6	12	12	-	M4
KHB9 and KHB20	M6/12	12	25	12	-	M6
	M8/12	25	35	12	-	M8
KHB9	M4/8	6	12	8	-	M4
KHB9	M6/8	12	25	8	-	M6
KHB20	M4/10	6	12	10	-	M4
KHB20	M6/10	12	25	10	-	M6

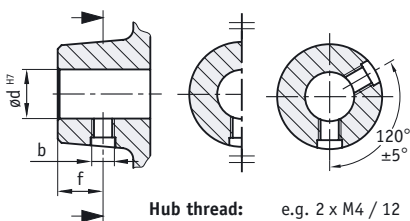
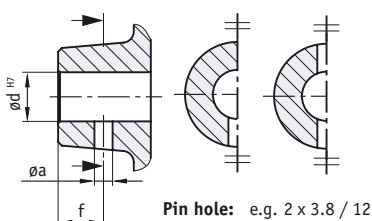

■ Hub turned down to length and circumference

Feature	Ordering date	Designation
Hub turned down	d1 (f7)xl	ød1 (f7) x length l
Example:	20x13	ø20 f7 x 13 mm

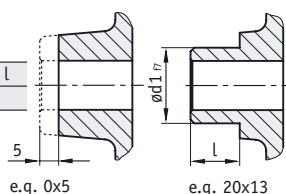

Fold-out Page

Reference tables

■ Gear ratios (also see free angle on page 6)

Type	Gear ratios
S50/1; S70/1; HR5	1; 2; 3; 6; 8; 10; 12; 15; 18; 20; 24; 30; 32; 36; 48; 50; 60; 72; 84; 96; 100; 120; 150; 200
S80/1; S120/1; HKF	1; 2; 3; 6; 8; 10; 12; 15; 18; 20; 24; 30; 36; 48; 50; 60; 72; 84; 96; 100; 120; 150; 200; 500; 600; 625
S0100	5; 6; 10; 15; 20; 50; 60; 80; 90; 100
SZ80/1	00002; 00003; 00004; 00005; 00006; 00008; 00010

■ Help for sketching of a custom scale:

