

ROTA^{MAG} Magnetic Rotary Encoders

Precise measurement of
angle of rotation, anytime –
... unaffected
by dirt and
vibration



Short profile

The ROTA^{MAG} family of rotary encoders opens up areas of application where optical measurement of distance, angle and rotational speed may lead to incorrect results. ROTA^{MAG} encoders are based on an indestructible magnetic scanning technology, which combines decisive advantages:

- Particularly high shock, vibration, and temperature resistance
- Absolutely insensitive to oil, lubricants, dirt and water
- Wear- and maintenance-free sensor unit
- Optional encapsulation of electronics enables its use also in the oil bath
- ROTA^{MAG} is universally applicable owing to different hollow and solid shaft versions
- Compact design thanks to a highly integrated sensor unit

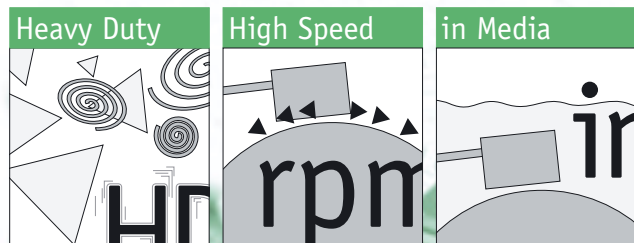
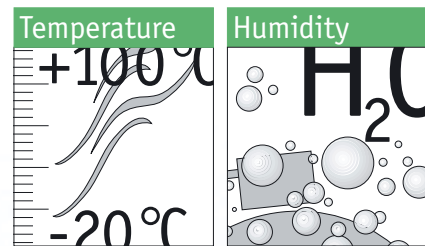

Contents

ROTAMAG Magnetic Rotary Encoders

4	ROTAMAG – Innovation and principle of functioning
5	Heavy-duty applications: Use under professional conditions
6	Easy to understand: Main areas of application
8	IV28M
10	IH28M
12	IV58M
14	IH58M
16	IG04M
18	IG07M
20	IG09M
22	Accessories
	Appendix/Circuits

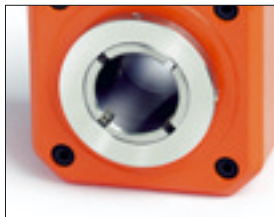

Magnetic rotary encoders – precise, tireless, and extremely reliable.

Time for a new generation, time for new standards!

Magnetic or optical? Under extreme industrial condition there is only one choice: SIKO's ROTAMAG .

With unprecedented reliability and precision, this SIKO development uses the fascinating advantages of a technology that is based on the varying pole forces of magnetism and is, therefore, not dependent on free sight or tidiness of the system.

Resolution, scanning accuracy and sturdiness of these compact measuring systems open new areas of application that go far beyond those possible with optical rotary encoders.

The high integration density of the device and its adjustment to established standards allow easy replacement of previously used encoders.

That's how the technology works:

Rotary movements of shafts or spindles are transmitted to a special electronic sensor system (2) via a magnetic ring (1) attached to the hollow or solid shaft. The pole division magnetised on the magnetic ring is transformed by a purpose-designed translation module into up to 2560 pulses per revolution. The incremental counting pulses are provided as a square-wave signal and can, therefore, be interpreted by any counting electronics. Furthermore, the sealing of the electronic components permits their safe use even in fluid media.

The high integration density of the device and its adjustment to established standards allow easy replacement of previously used encoders.

This technology is intended for operating environments where dirt and humidity prevail or where vibrations caused by the machinery make precise working difficult. The contactlessly measuring rotary encoders are nearly universally usable – even in combination with aggressive solutions such as salt water or in temperature-regulated oily environments.

In many industrial sectors, including food or packing industries, energy production or wood processing, passenger transport or in the complete area of mechanical engineering: the limits of optical measuring systems are insurmountable due to their inherent principle.

In contrast, SIKO's magnetic systems are in top form for these applications.

The signal path: A sensor scans the north and south poles of the specially magnetized ferrite ring and generates

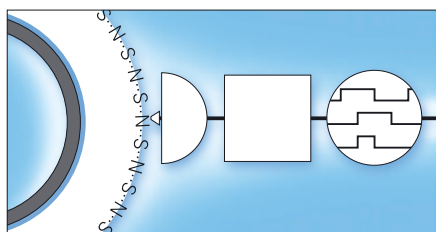

pulses that are processed real-time and provided as digital signals.

Digital output signal (3)

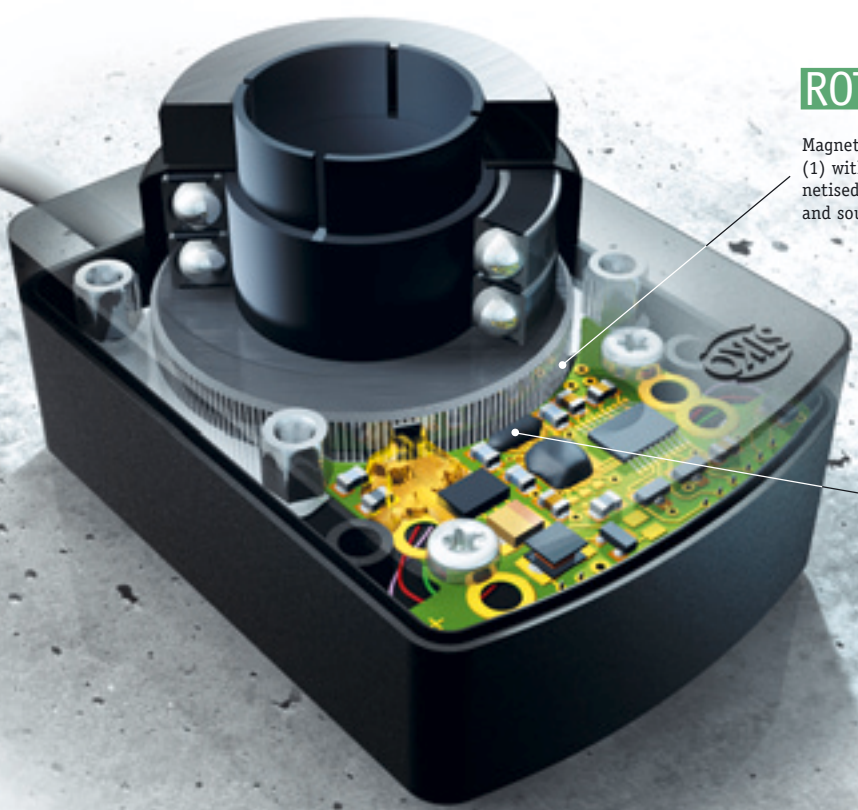

ROTA^{MAG}

Magnetic ring (1) with magnetised north and south poles

Sensor (2) with following real-time processing

Extreme vibrations as well as humid, caked abrasion make measurement control in rough wood processing difficult.



Abrasion, a fatty-greasy environment, temperature fluctuation as in lift technology or vibrations from punching or pressing machines that weigh many tons are no problem for the ROTAMAG.

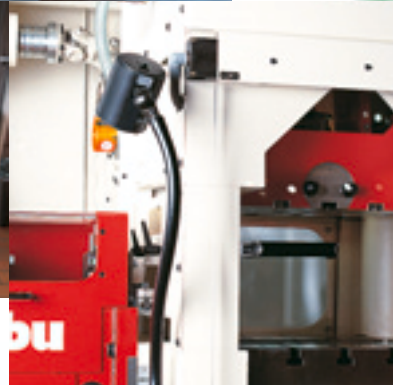

Scanning the measuring value under highly dynamic conditions: Balancing wheels involves a greasy environment full of micronised dust.



Many food production processes are accompanied by humidity, temperature fluctuation and aggressive cleaning agents.

"When you plane, you get shavings." Together with dust and abrasion and in combination with humidity, lubricants, vibration and temperature, these shavings are an absolute "killer environment" for constantly precise measurements. SIKO presents its new ROTAMAG magnetic measuring technology for rotary encoders, which guarantees consistent production safety in all border areas of industrial production.

industries should not be underestimated. Here, maintenance-free operation and reliability in a rough competitive environment are indispensable. Where else are so many applications interconnected, which all require similarly high and reliable production quality?

Therefore, the magnetic ROTAMAG rotary encoders are ideal for applications such as...

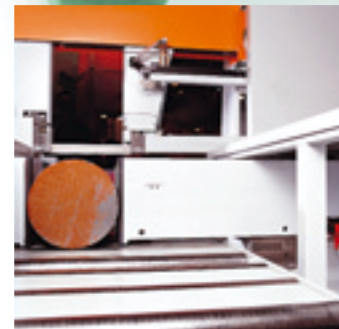

Vibrations, refrigerants and lubricants determine the atmosphere for metal-cutting saws.

Magnetic measurement Heavy-duty industrial applications... – clear advantage

Everybody understands the difficult conditions

of stone working or tunnelling. However, the parallel in wood or metal processing

- Sheet metal processing with punching and deformation techniques
- Lifting techniques
- Offshore environments
- Packaging and food industries
- Chemical-pharmaceutical industries
- Energy production (e.g., wind generators)
- Wherever precise measurement is required under difficult conditions

Main areas of application

Versatile, simple and always ready: SIKO's ROTAMAG rotary encoders

Environmental conditions

Functioning

Advantages

Humidity



Insensitive to humidity, since the scanning principle does not require visual contact.

- No mounting precautions necessary with regard to protection from humidity

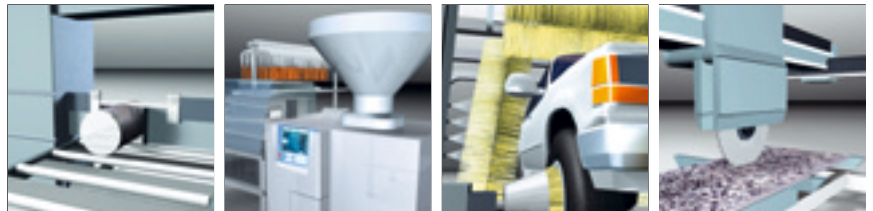

e.g., metal-cutting saws, food production, car washes, stoneworking ...

Shock and vibration



Indestructible: The components used are unbreakable; there is no glass pane as known from optical encoders, all components are safely integrated.

- High reliability
- No complicated mechanical uncoupling necessary



e.g., pressing and punching machines, construction equipment, lifts, rough wood processing...

Fluctuation of climate



Absolutely safe operation with condensation due to rapid changes of temperature or icing up of components in free-standing installations.

- High operational safety
- Maintenance-free

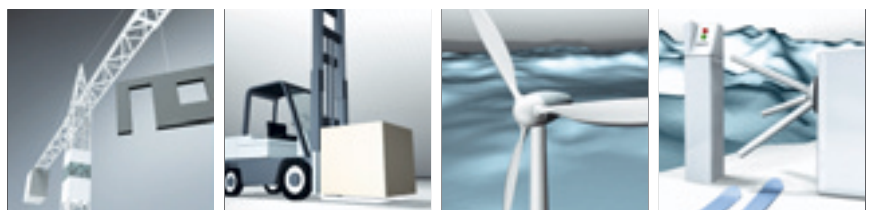

e.g., cranes, forklifts, wind generators, ski lifts...

Dirt



The encapsulated housing as well as scanning without sight and contact make the technique robust against invading particles.

- High operational safety
- no additional precautions necessary



e.g., wood processing, construction equipment, tunnel advance ...



Example of use

*You can count on it.

ROTAMAG rotary encoders are most reliable partners even under the most difficult conditions. No more problems due to ...

- Shock and vibration
- Oily or salty humidity
- Dirt of any kind
- Significant temperature fluctuation
- Any combination of the above-mentioned factors

Incremental encoders IV28M

Miniature rotary encoders with high precision: The encapsulated solid shaft encoder IV28M can take a lot with regard to vibration, dirt, and humidity and convince with their particularly compact design.



Features:

- up to 1000 pulses/revolution
- PP, OP, LD5, LD24 output circuit
- solid shafts up to 6 mm diam.
- IP54 or higher type of protection
- 28 mm flange diameter

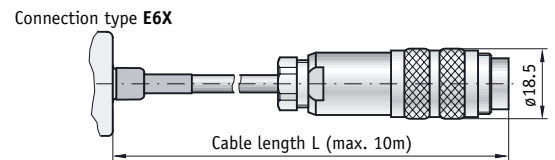
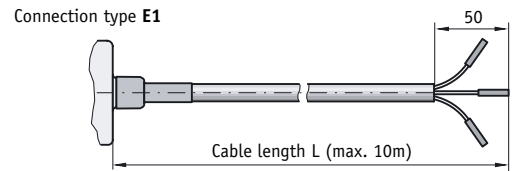
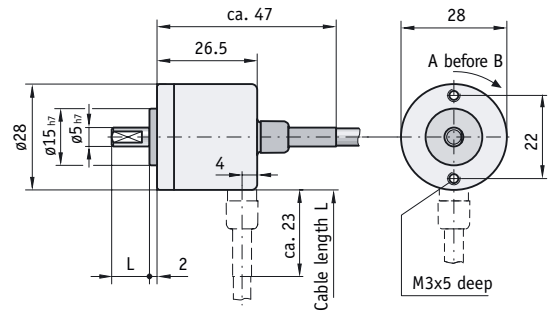

Pin-outs

E6X PIN	E1 Core colours	PP Signal
1	white	B
2	brown	+UB
3	green	0/I
4	yellow	A
5	grey	GND
6		
7		

E6X PIN	E1 Core colours	OP/LD24/LD5 Signal
A	blue	/B
B		
C	green	0
D	red	/0
E	yellow	A
F	pink	/A
G		
H	white	B
I		
K	grey	GND
L		
M	brown	+UB

Feature	Technical data	Additional information
Type of protection	IP54	
Max. rotational speed	3000 min ⁻¹	
Shaft moment of inertia	~0.24 x 10 ⁻⁶ kgm ²	
Starting torque (+20 °C)	≤0.1 Ncm	
Load capacity of shaft	radial 30 N, axial 15 N	only IV28M
Weight	~0.1 kg	
Working temperature	-20 °C ... +70 °C	storage temperature -20 °C ... +80 °C
Cable sheath	PUR	
Shock resistance	200 g/6 ms	acc. to DIN-IEC 68-2-27
Vibration resistance	10 g/50 Hz	acc. to DIN-IEC 68-2-6
Operating voltage	10 ... 30 V DC (PP, OP, LD24)	
	5 V DC ± 5% (LD5)	
Power cons. without load (typ.)	<25 mA	ABO version
Perm. load/channel (max.)	±30 mA	short-time up to 100 mA, t < 5 s
Pulse frequency (max.)	200 kHz	
Phase position	90° ± 15°	
Signal level high (min.)	29.2 V DC (not with LD5, LD24)	Ub = 30 V DC, I oh = -30 mA
Signal level low (max.)	0.5 V DC (not with LD5, LD24)	Ub = 30 V DC, I ol = 30 mA
Polarity protection on UB	yes (PP, OP, LD24), no (LD5)	
Housing	aluminium/plastic	
Shaft	stainless steel	
Test mark	CE	acc. to EN 61000-6-2, EN 61000-6-4

Ordering data

Output signals (see appendix)	ABX	A		standard
	ABO			
	ABI			
Pulses/revolution	...	B	50 ... 1000 in 50-increments	
Type of connection	E1	C	cable sleeve with flying leads	
	E6X		connector	
Cable length [m]	1.0	D	from 1.0 ... 10.0 m in steps of 1.0 m (E1)	standard
	0.3		only for E6X	
Output circuit (see appendix)	PP	E	push-pull	standard
	OP		push-pull, with inverted signals	
	LD5		line driver, 5 V DC encoder supply	RS422 A spec.
	LD24		line driver, 24 V DC encoder supply	RS422 A spec.
Shaft diameter	...	F	max. 8 mm	standard , hollow shaft
	5 x 10			standard , solid shaft

Accessories in the appendix

Your order: - - - - - - -

Incremental encoders IH28M

Miniature rotary encoders with high precision: The encapsulated encoder IH28M can take a lot with regard to vibration, dirt, and humidity and convince with their particularly compact design with through hollow shaft.



Features:

- up to 1000 pulses/revolution
- PP, OP, LD5, LD24 output circuit
- hollow shaft up to 8 mm diam./stainless steel
- IP54 or higher type of protection
- 28 mm flange diameter

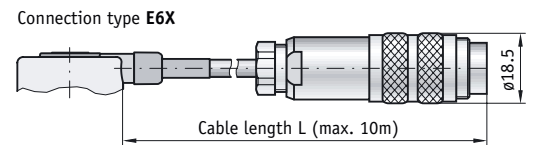
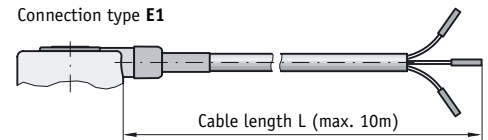
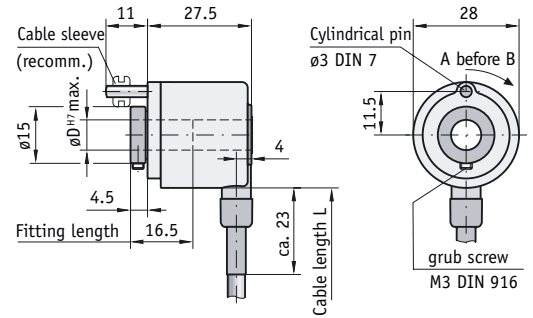

Pin-outs

E6X PIN	E1 Core colours	PP Signal
1	white	B
2	brown	+UB
3	green	0/I
4	yellow	A
5	grey	GND
6		
7		

E6X PIN	E1 Core colours	OP/LD24/LD5 Signal
A	blue	/B
B		
C	green	0
D	red	/0
E	yellow	A
F	pink	/A
G		
H	white	B
I		
K	grey	GND
L		
M	brown	+UB

Feature	Technical data	Additional information
Type of protection	IP54	
Max. rotational speed	3000 min ⁻¹	
Shaft moment of inertia	~0.24 x 10 ⁻⁶ kgm ²	
Starting torque (+20 °C)	≤0.1 Ncm	
Load capacity of shaft	radial 30 N, axial 15 N	only IV28M
Weight	~0.1 kg	
Working temperature	-20 °C ... +70 °C	storage temperature -20 °C ... +80 °C
Cable sheath	PUR	
Shock resistance	200 g/6 ms	acc. to DIN-IEC 68-2-27
Vibration resistance	10 g/50 Hz	acc. to DIN-IEC 68-2-6
Operating voltage	10 ... 30 V DC (PP, OP, LD24)	
	5 V DC ± 5% (LD5)	
Power cons. without load (typ.)	<25 mA	ABO version
Perm. load/channel (max.)	±30 mA	short-time up to 100 mA, t < 5 s
Pulse frequency (max.)	200 kHz	
Phase position	90° ± 15°	
Signal level high (min.)	29.2 V DC (not with LD5, LD24)	Ub = 30 V DC, I oh = -30 mA
Signal level low (max.)	0.5 V DC (not with LD5, LD24)	Ub = 30 V DC, I ol = 30 mA
Polarity protection on UB	yes (PP, OP, LD24), no (LD5)	
Housing	aluminium/plastic	
Shaft	stainless steel	
Test mark	CE	acc. to EN 61000-6-2, EN 61000-6-4

Ordering data

Output signals (see appendix)	ABX	A		standard
	ABO			
	ABI			
Pulses/revolution	...	B	50 ... 1000 in 50-increments	
Type of connection	E1	C	cable sleeve with flying leads	
	E6X		connector	
Cable length [m]	1.0	D	from 1.0 ... 10.0 m in steps of 1.0 m (E1)	standard
	0.3		only for E6X	
Output circuit (see appendix)	PP	E	push-pull	standard
	OP		push-pull, with inverted signals	
	LD5		line driver, 5 V DC encoder supply	RS422 A spec.
	LD24		line driver, 24 V DC encoder supply	RS422 A spec.
Shaft diameter	...	F	max. 8 mm	standard , hollow shaft
	5 x 10			standard , solid shaft

Accessories in the appendix

Your order: - IH28M - - - - - -

Incremental encoder IV58M

The rotary encoder IV58M is extremely resistant to dirt, humidity, and vibration. Robust in standard design combines the advantages of magnetic scanning and an encapsulated aluminium housing.



Features:

- 58 mm servo or clamping flange
- up to 2560 pulses/revolution
- solid shafts up to 10 mm diameter, stainless steel

Options:

Sealed electronics (condensation permitted)

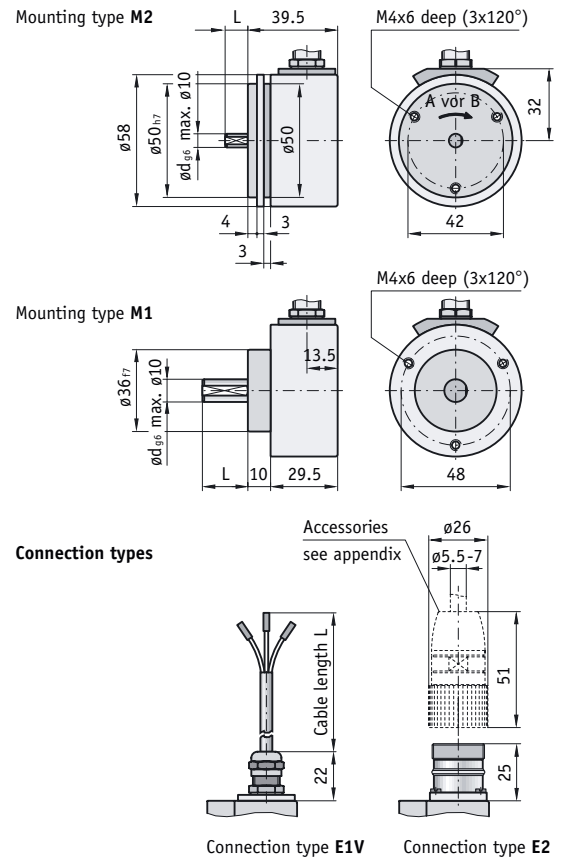

Pin-outs

E2 PIN	E1T, E1V Core colours	PP Signal	OP/LD24 Signal	LD5 Signal
1	blue		/B	/B
2	violet			+SUB
3	green	0/I	0	0
4	red		/0	/0
5	yellow	A	A	A
6	pink		/A	/A
7				
8	white	B	B	B
9				
10	grey	GND	GND	GND
11	black			SGND
12	brown	+UB	+UB	+UB

Feature	IV58M	Technical data	Additional information
Type of protection		IP65	
Max. rotational speed		6000 min ⁻¹	
Shaft moment of inertia		~0.15 × 10 ⁻⁶ kgm ²	
Starting torque (+20 °C)		≤1.5 Ncm	
Load capacity of shaft		radial 80 N, axial 40 N	
Weight		0.4 kg	
Working temperature		-20 °C ... +100 °C	storage temperature -20 °C ... +100 °C
Cable sheath		PUR	
Shock resistance		200 g/6 ms	acc. to DIN-IEC 68-2-27
Vibration resistance		10 g/50 Hz	acc. to DIN-IEC 68-2-6
Operating voltage		10 ... 30 V DC (PP, OP, LD24)	
		5 V DC ± 5 % (LD5)	
Power cons. without load (typ.)		<25 mA	Ub = 24 V DC, ABO version
Perm. load/channel (max.)		±30 mA	short-time up to 100 mA, t < 5 s
Pulse frequency (max.)		100 kHz	at 6000 min ⁻¹ and 1000 increments
Phase position		90° ± 15°	
Signal level high (min.)		29.2 V DC (PP, OP)	Ub = 30 V DC, I oh = -30 mA
Signal level low (max.)		0.5 V DC (PP, OP)	Ub = 30 V DC, I ol = 30 mA
Signal level LD5, LD24		RS422 A spec.	
Polarity protection on UB		yes (PP, OP, LD24)	
Housing		aluminium	
Shaft		stainless steel	
Test mark		CE	acc. to EN 61000-6-2, EN 61000-6-4

Ordering data

Output signals (see appendix)	ABX ABO ABI	A		standard
Pulses/revolution	...	B	50, 64, 100, 128, 200, 250, 320, 400, 500, 512, 1000, 1024, 1280, 1600, 2000, 2048, 2560	others on request
Type of connection	E1V E2	C	screwing with flying leads connector	standard
Cable length [m]	1.0	D	from 1.0 to 20.0 m in in steps of 1.0	standard
Mounting mode	M1 M2	E	clamping flange servo flange	
Output circuit (see appendix)	PP OP LD5 LD24	F	push-pull push-pull, with inverted signals line driver, 5 V DC encoder supply line driver, 24 V DC encoder supply	standard RS422 A spec. RS422 A spec.
Shaft diameter (diam. x L)	6 x 10 8 x 10 10 x 20	G	diam. 6 mm x 10 mm diam. 8 mm x 10 mm diam. 10 mm x 20 mm	
Environmental conditions	S E	H	condensation not permitted condensation permitted	standard

Accessories in the appendix

Your order: - - - - - - - - -

Incremental encoder IH58M

The IH58M is SIKO's the most compact hollow shaft encoder With bores up to 22 mm diameter and high precision. Dirt, humidity and vibration do not affect this encoder.



Features:

- 58 mm flange diameter
- up to 2560 pulses/revolution
- hollow shafts up to 22 mm diam.

Options:

- sealed electronics (condensation permitted)

Shaft version
Grub screw **GW**

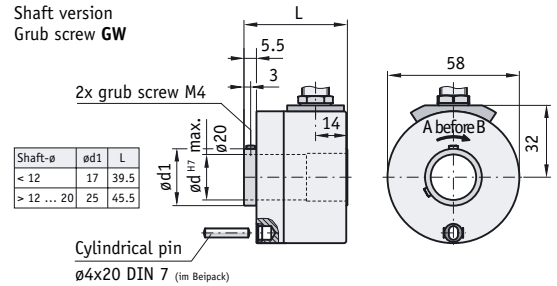

Shaft version
Clamping ring **KL**

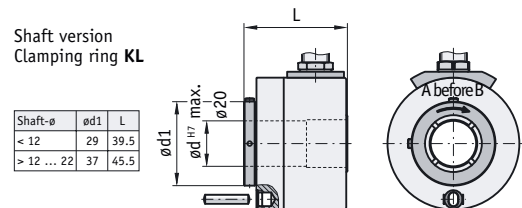

Recommended intallation

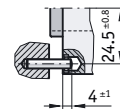

Connection types

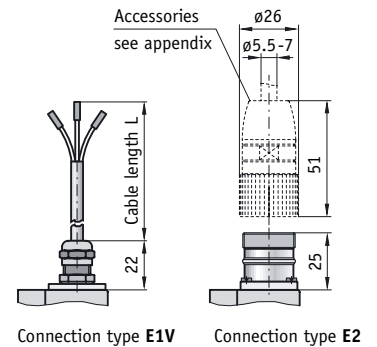

Pin-outs

E2 PIN	E1T, E1V Core colours	PP Signal	OP/LD24 Signal	LD5 Signal
1	blue		/B	/B
2	violet			+SUB
3	green	0/I	0	0
4	red		/0	/0
5	yellow	A	A	A
6	pink		/A	/A
7				
8	white	B	B	B
9				
10	grey	GND	GND	GND
11	black			SGND
12	brown	+UB	+UB	+UB

Feature	IH58M	Technical data	Additional information
Type of protection		IP65	
Max. rotational speed		6000 min ⁻¹	
Shaft moment of inertia		~0.3 x 10 ⁻⁶ kgm ²	
Starting torque (+20 °C)		≤4 Ncm	
Weight		0.4 kg	
Working temperature		-20 °C ... +100 °C	storage temperature -20 °C ... +100 °C
Cable sheath		PUR	
Shock resistance		200 g/6 ms	acc. to DIN-IEC 68-2-27
Vibration resistance		10 g/50 Hz	acc. to DIN-IEC 68-2-6
Operating voltage		10 ... 30 V DC (PP, OP, LD24)	
		5 V DC ± 5 % (LD5)	
Power cons. without load (typ.)		<25 mA	Ub = 24 V DC, ABO version
Perm. load/channel (max.)		±30 mA	short-time up to 100 mA, t < 5 s
Pulse frequency (max.)		100 kHz	at 6000 min ⁻¹ and 1000 increments
Phase position		90° ± 15°	
Signal level high (min.)		29.2 V DC	Ub = 30 V DC, I oh = -30 mA
Signal level low (max.)		0.5 V DC	Ub = 30 V DC, I ol = 30 mA
Signal level LD5, LD24		RS422 A spec.	
Polarity protection on UB		yes (PP, OP, LD24)	
Housing		aluminium	
Shaft		stainless steel	
Test mark		CE	acc. to EN 61000-6-2, EN 61000-6-4

Ordering data

Output signals (see appendix)	ABX	A		standard
	ABO			
	ABI			
Pulses/revolution	...	B	50, 64, 100, 128, 200, 250, 256, 320, 400, 500, 512, 1000, 1024, 1280, 1600, 2000, 2048, 2560	others on request
Type of connection	E1V	C	PG screwing with flying leads	standard
	E2		connector	
Cable length [m]	1.0	D	from 1.0 to 20.0 m in in steps of 1.0	standard
Output circuit (see appendix)	PP	E	push-pull	standard
	OP		push-pull, with inverted signals	
	LD5		line driver, 5 V DC encoder supply	RS422 A spec.
	LD24		line driver, 24 V DC encoder supply	RS422 A spec.
Fixing version	GW	F	fastening with headless screw	diam. 6 ... 20 mm
	KL		fastening with clamping ring	diam. 14 ... 22 mm
Shaft diameter	...	G	6, 8, 10, 12, 14, 15, 20, 22	
Environmental conditions	S	H	condensation not permitted	standard
	E		condensation permitted	

Accessories in the appendix

Your order: - - - - - - - - -

Incremental encoder IG04M

High resolution, robust magnetic scanning, stable plastic housing in very flat design. Designed for applications with very confined space including motive power engineering, medical equipment, etc.



Features:

- compact installation depth
- max. resolution 2000 pulses/revolution
- hollow shafts up to 14 mm diam.
- combination with mech. counter, type DA04

Options:

- intermediate plate

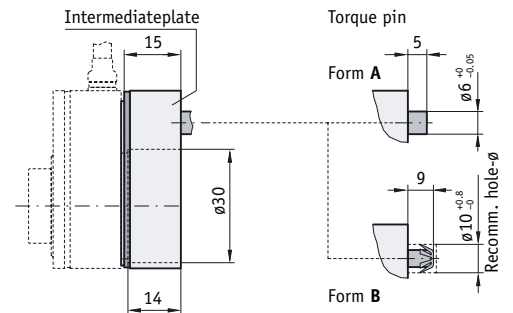
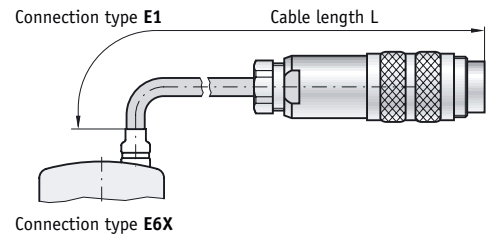
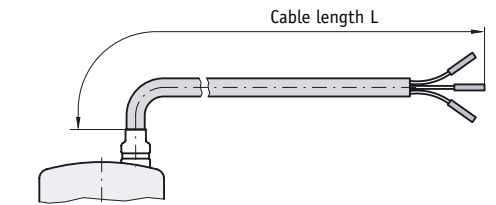
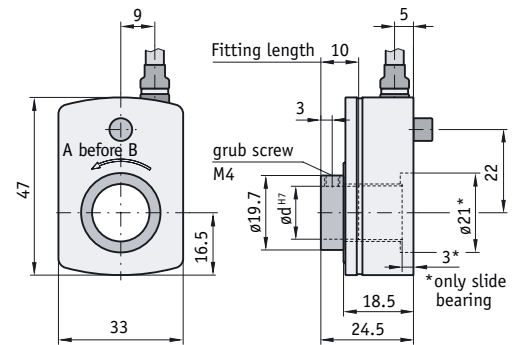

Pin-outs

E6X PIN	E1 Core colours	PP Signal
1	white	B
2	brown	+UB
3	green	0/I
4	yellow	A
5	grey	GND
6		
7		

E6X PIN	E1 Core colours	OP/LD24/LD5 Signal
A	blue	/B
B		
C	green	0
D	red	/0
E	yellow	A
F	pink	/A
G		
H	white	B
I		
K	grey	GND
L		
M	brown	+UB

Feature	Technical data		Additional information
Type of protection		IP53 slide bearing; IP63 ball bearing	
Max. rotational speed		slide bearing shor term 600 min ⁻¹	ball bearing 3000 min ⁻¹
Shaft moment of inertia		~0.9 x 10 ⁻⁶ kgm ²	
Weight		appr. 0.1 kg	
Working temperature		-20 °C ... +70 °C	storage temperature -20 °C ... +80 °C
Cable sheath		PUR	
Shock resistance		200 g/6 ms	acc. to DIN-IEC 68-2-27
Vibration resistance		10 g/50 Hz	acc. to DIN-IEC 68-2-6
Operating voltage		10 ... 30 V DC (PP, OP, LD24)	
		5 V DC ± 5% (LD5)	
Power cons. without load (typ.)		<20 mA	ABO version
Perm. load/channel (max.)		±30 mA	short-time up to 100 mA, t < 5 s
Pulse frequency (max.)		100 kHz	
Phase position		90° ± 15°	
Signal level high (min.)		29.2 V DC (not with LD5, LD24)	Ub = 30 V DC, I oh = -30 mA
Signal level low (max.)		0.5 V DC (not with LD5, LD24)	Ub = 30 V DC, I ol = 30 mA
Signal level LD5, LD24		RS422 A Spec.	
Polarity protection on UB		yes (PP, OP, LD24), no (LD5)	
Housing		reinforced plastic	
Shaft		blue steel	
Test mark		CE	acc. to EN 61000-6-2, EN 61000-6-4

Ordering data

Output signals (see appendix)	ABX	A		standard
	ABO			
	ABI			
Pulses/revolution	...	B	50 ... 2000 in 50-increments	
Cable outlet	L0	C	see drawing	
Type of connection	E1	D	PG screwing with flying leads	standard
	E6X		plug connection	
Cable length [m]	1.0	E	1.0 ... 10.0 m in steps of 1.0 m	standard , LD5 max. 3 m
Output circuit (see appendix)	PP	F	push-pull	standard
	OP		push-pull, with inverted signals	
	LD5		line driver, 5 V DC encoder supply	RS422 A spec.
	LD24		line driver, 24 V DC encoder supply	RS422 A spec.
Shaft ø	G14	G	slide bearing ø14 mm	standard
	K10		ball bearing ø10 mm	
Torque support form	A	H	cylindrical pin, diam. 6 mm	standard
	B		for mech. tolerance compensation	
Intermediate plate	OZP	I	with	standard
	ZP		without	

Accessories in the appendix

Your order: - - - - - - - - - -

Incremental encoder IG07M

Rough environmental conditions are the business of the IG07M: Robust magnetic scanning in a stable die-casting housing make the IG07M a particularly sturdy rotary encoder solution.



Features:

- resolution max. 2560 pulses/revolution
- housing made of zinc die-casting
- solid shafts up to 20 mm diam., stainless steel
- high axial and radial load capacity of shaft

Options:

- sealed electronics (condensation permitted)

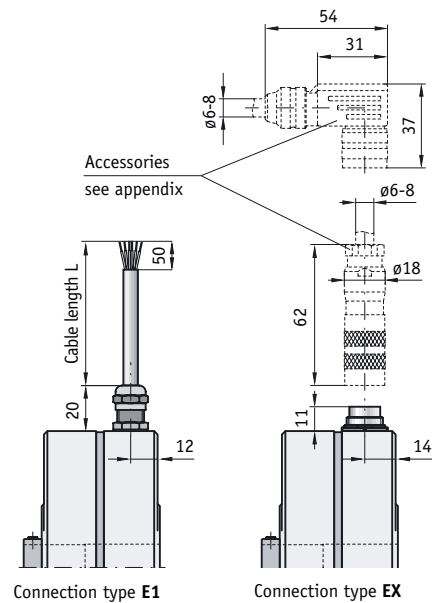
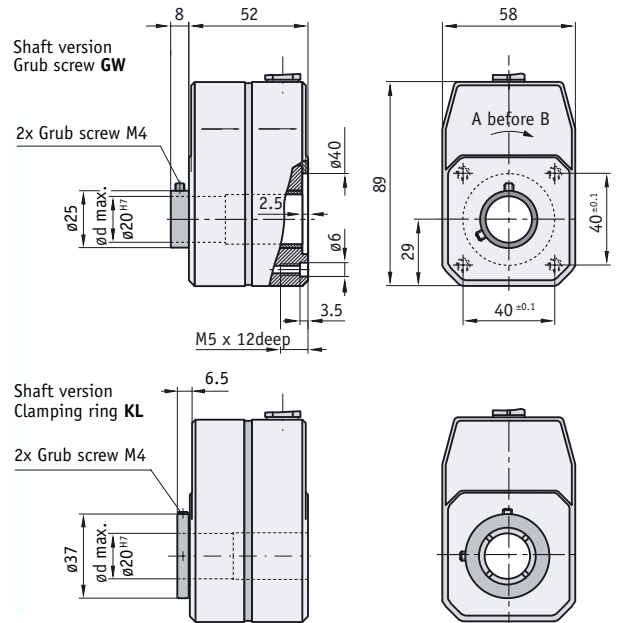

Pin-outs

EX PIN	E1 Core colours	PP Signal	OP/LD24 Signal	LD5 Signal
A	blue		/B	/B
B	violet			+SUB
C	green	0/I	0	0
D	red		/0	/0
E	yellow	A	A	A
F	pink		/A	/A
G				
H	white	B	B	B
I				
K	grey	GND	GND	GND
L	black			SGND
M	brown	+UB	+UB	+UB

Feature	Technical data		Additional information
Type of protection	IP64		
Max. rotational speed	6000 min ⁻¹ (IP64), 3000 min ⁻¹ (IP65)		
Shaft moment of inertia	~0.3 x 10 ⁻⁶ kgm ²		
Starting torque (20 °C)	≤6 Ncm (IP64), ≤10 Ncm (IP65)		
Load capacity of shaft	radial 5600 N, axial 1400 N		
Weight	approx. 0.75 kg		
Working temperature	-20 °C ... +100 °C		storage temperature -20 °C ... +100 °C
Cable sheath	PUR		
Shock resistance	200 g/6 ms		acc. to DIN-IEC 68-2-27
Vibration resistance	10 g/50 Hz		acc. to DIN-IEC 68-2-6
Operating voltage	10 ... 30 V DC (PP, OP, LD24)		
	5 V DC ± 5% (LD5)		
Power cons. without load (typ.)	<25 mA		Ub = 24 V DC, ABO version
Perm. load/channel (max.)	±30 mA		short-time up to 100 mA, t < 5 s
Pulse frequency (max.)	100 kHz		at 6000 min ⁻¹ and 1000 increments
Phase position	90° ± 15°		
Signal level high (min.)	29.2 V DC		Ub = 30 V DC, I oh = -30 mA
Signal level low (max.)	0.5 V DC		Ub = 30 V DC, I ol = 30 mA
Signal level LD5, LD24	RS422 A spec.		
Polarity protection on UB	yes (PP, OP, LD24)		
Housing	zinc die-casting		
Shaft	stainless steel		
Test mark	CE		acc. to EN 61000-6-2, EN 61000-6-4
Ordering data			
Output signals (see appendix)	ABX ABO ABI	A	standard
Pulses/revolution	...	B	50, 64, 100, 128, 200, 250, 256, 320, 400, 500, 512, 1000, 1024, 1280, 1600, 2000, 2048, 2560 others on request
Type of connection	E1 EX	C	PG screwing with flying leads plug connection standard
Cable length [m]	1.0	D	from 1.0 to 20.0 m in in steps of 1.0 standard
Output circuit (see appendix)	PP OP LD5 LD24	E	push-pull push-pull, with inverted signals line driver, 5 V DC encoder supply line driver, 24 V DC encoder supply standard RS422 A spec. RS422 A spec.
Fixing version	GW KL	F	fastening with headless screw fastening with clamping ring
Shaft diameter	20	G	in mm standard
Mounting mode	M1	H	standard
Storage	MS RS	I	high precision sealing gap enhanced sealing of bearing standard
Environmental conditions	S E	K	condensation not permitted condensation permitted standard

Accessories in the appendix

Your order: - - - - - - - - - - -

Incremental encoder IG09M

High resolution, robust magnetic scanning, stable plastic housing in very flat design– the hollow shaft encoder IG09M suit many applications.



Features:

- compact installation depth
- max. resolution 2560 pulses/revolution
- hollow shafts up to 20 mm diam.
- combination with mech. counter, type DA09S

Options:

- sealed electronics (condensation permitted)

Special feature:

Combination of the IG09M with mechanical DA09S encoders on the same shaft/spindle has been prepared for attaining fast control of adjustment values. Mating on each housing guarantees safe compact installation.

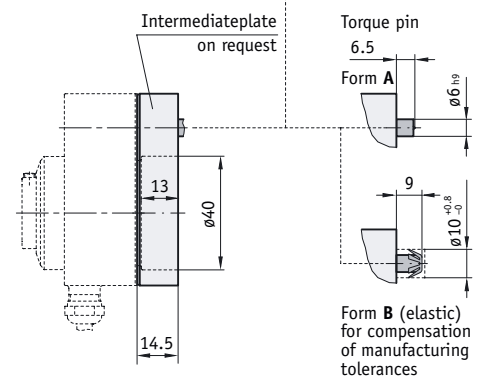
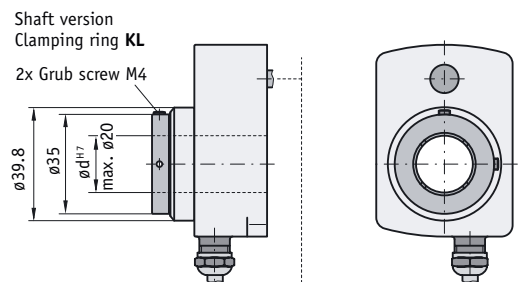
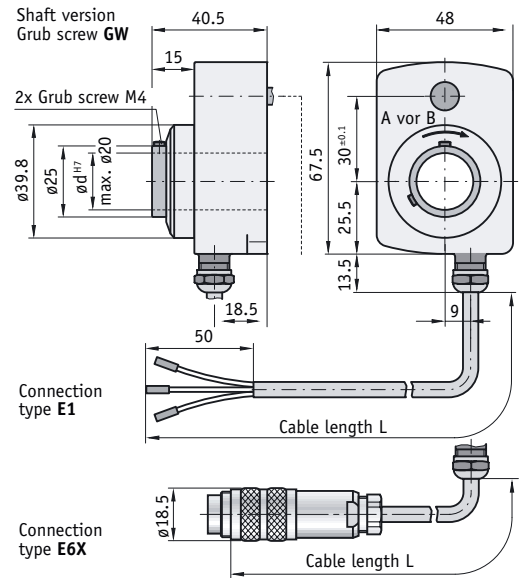

Pin-outs

E6X PIN	E1 Core colours	PP Signal	OP/LD24/LD5 Signal
A	blue		/B
B			
C	green	0/I	0
D	red		/0
E	yellow	A	A
F	pink		/A
G			
H	white	B	B
I			
K	grey	GND	GND
L			
M	brown	+UB	+UB

Feature	Technical data	Additional information
Type of protection	IP53/IP63	
Max. rotational speed	6000 min ⁻¹	
Shaft moment of inertia	~0.15 x 10 ⁻⁶ kgm ²	
Starting torque (+20 °C)	≤2 Ncm (IP53), ≤3.5 Ncm (IP63)	
Weight	appr. 0.12 kg	
Working temperature	-20 °C ... +100 °C	storage temperature -20 °C ... +100 °C
Cable sheath	PUR	
Shock resistance	200 g/6 ms	acc. to DIN-IEC 68-2-27
Vibration resistance	10 g/50 Hz	acc. to DIN-IEC 68-2-6
Operating voltage	10 ... 30 V DC (PP, OP, LD24)	
	5 V DC ± 5% (LD5)	
Power cons. without load (typ.)	<25 mA	Ub = 24 V DC, ABO version
Perm. load/channel (max.)	±30 mA	short-time up to 100 mA, t < 5 s
Pulse frequency (max.)	100 kHz	at 6000 min ⁻¹ and 1000 increments
Phase position	90° ± 15°	
Signal level high (min.)	29.2 V DC	Ub = 30 V DC, I _{oh} = -30 mA
Signal level low (max.)	0.5 V DC	Ub = 30 V DC, I _{ol} = 30 mA
Signal level LD5, LD24	RS422 A Spec.	
Polarity protection on UB	yes (PP, OP, LD24)	
Housing	reinforced plastic	
Shaft	blue steel	
Test mark	CE	acc. to EN 61000-6-2, EN 61000-6-4

Ordering data

Output signals (see appendix)	ABX	A		standard
	ABO			
	ABI			
Pulses/revolution	...	B	50, 64, 100, 128, 200, 250, 256, 320, 400, 500, 512, 1000, 1024, 1280, 1600, 2000, 2048, 2560	others on request
Type of connection	E1	C	PG screwing with flying leads	standard
	E6X		plug connection	
Cable length [m]	1.0	D	from 1.0 to 20.0 m in steps of 1.0 m LD5 max. 3 m	standard
Output circuit (see appendix)	PP	E	push-pull	standard
	OP		push-pull, with inverted signals	
	LD5		line driver, 5 V DC encoder supply	RS422 A spec.
	LD24		line driver, 24 V DC encoder supply	RS422 A spec.
Fixing version	GW	F	fastening with headless screw	
	KL		fastening with clamping ring	
Shaft diameter	...	G	12, 14, 15, 20 in mm	
Environmental conditions	S	H	condensation not permitted	standard
	E		condensation permitted	
Torque support form	A	I	cylindrical pin, diam. 6 mm	standard
	B		for mech. tolerance compensation	
Type of protection	IP53	K		standard
	IP63			

Accessories in the appendix

Your order: - - - - - - - - - - -

Matching Accessories for all ROTA^{MAG} Products

Cable extensions

in 7-, 10- and 12-core design with twisted screening braid.
The mass-produced product has stripped and tinned cable ends.

IG07M:
Cable extension with angular box "W"

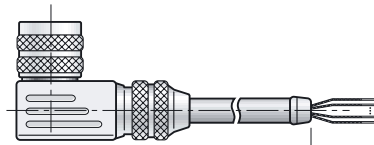

IH28M, IV28M, IG04M, IG07M, IG09M:
Cable extension with coupling box "GE"

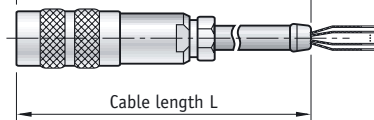

IV58M, IH58M:
Cable extension with coupling box "GE"

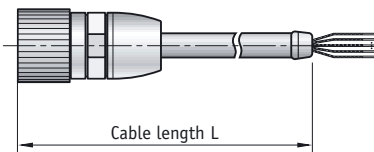

Ordering information for coupling boxes without cable extension

only angular box:
IG07M: Item no. 79666
Cable diam. 6-8 mm

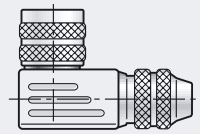

only coupling box:
IH28M, IV28M, IG04M:
Item no. 76141 (7-pin)
IG04M, IG07M, IG09M:
Item no. 76572 (12-pin)
Cable diam. 6-8 mm

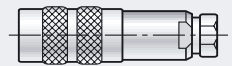

only coupling box:
IV58M/IH58M: Item no. 81935
Cable diam. 5.5-7 mm

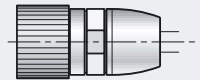

Feature	Ordering data			Technical data	Additional information
for connector	7-PIN	10-PIN	12-PIN		
Cable extension	KV07-0 A	KV10-0 A	KV12-0 A		
Type of connection	GE B	GE B	GE W B		straight coupling box angular coupling box
Cable length	1.0 C	1.0 C	1.0 C	length in meter 1.0 m to 10.0 m in steps of 0.1 m	standard 1.0 m

Pin assignment

PIN	KV07-0	PIN	KV10-0	PIN	KV012-1
1	white	1	blue	A	blue
2	brown	2	violet	B	violet
3	green	3	green	C	green
4	yellow	4	red	D	red
5	grey	5	yellow	E	yellow
6	pink	6	pink	F	pink
7	blue	7	--	G	red-blue
		8	white	H	white
		9	--	I	grey-pink
		10	grey	K	grey
		11	black	L	black
		12	brown	M	brown

for all connectors: screen on housing

Your order: KV -0 - B - C

Flexible coupling AK18

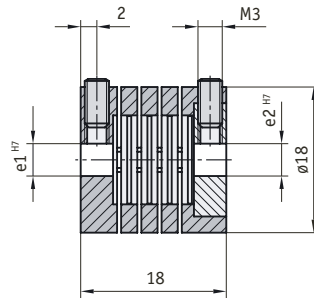

Your order: - /

We recommend using a flexible coupling clutch for backlash-free compensation of mechanical errors when mounting solid shaft encoders avoid tension on the bearings (due to shaft displacement caused by misalignment).

Material	aluminium
Max. rotational speed	25000 min ⁻¹
Max. perm. displacement	0.1 mm (radial/axial)
Bore diameter	e1 / e2, (e1 = e2/ standard)
e1/e2	4, 5, 6, 8, 10 mm*

*other diameters on request

Servo clamp SK

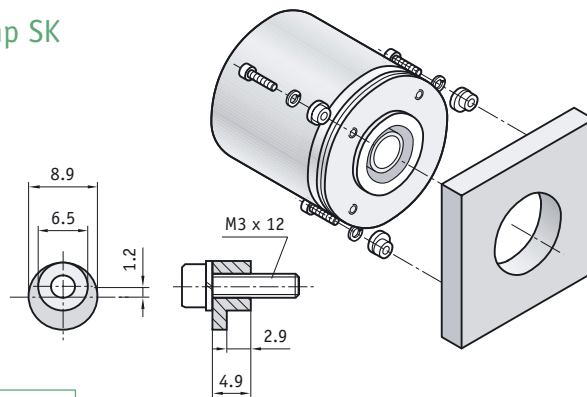

Your order:

Incremental encoders with servo flange can be easily and safely mounted by means of servo clamps. Three clamps are recommended for a secure fastening.

Content per packaging unit(SK):

1 servo clamp (1 x fastening eccentric, lock washer and cheese-head screw with hexagon socket)

Appendix/Circuits

Circuit diagrams

PP
(push-pull)

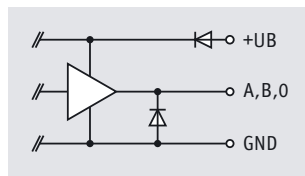

OP
(push-pull, complementary)

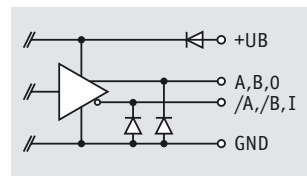

LD5
(line driver)

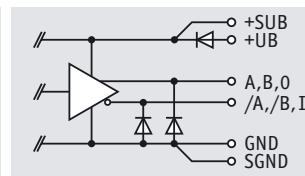

LD24
(line driver, 24 V DC supply)

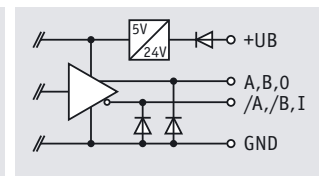

Output circuits

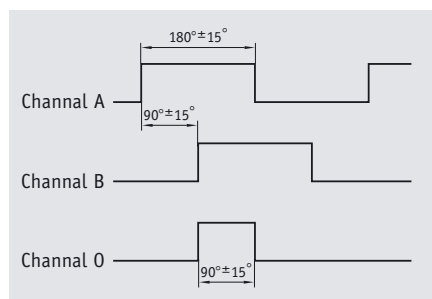
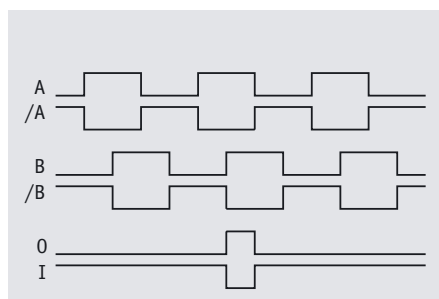

**SIKO GmbH**

Weihermattenweg 2
79256 Buchenbach
Germany

Telephone

+49 7661 394-0

Telefax

+49 7661 394-388

E-Mail

info@siko.de

Internet

www.siko.de

Looking for a dealer near
to you?

You can find the complete
addresses of all SIKO product
representatives in the support
section of our website:

www.siko.de

SIKO Products Inc.

P.O. Box 279
Dexter, MI 48130
USA

Telephone

+1 734 42 63 476

Telefax

+1 734 42 63 453

E-Mail

sales@sikoproducts.com

Internet

www.sikoproducts.com

SIKO Ltd.

Unit 6, Dalton Lane
Codbeck Estate, Dalton
Thirsk, North Yorkshire
YO7 3HR
United Kingdom

Telephone

+44 1845 578845

Telefax

+44 1845 577781

E-Mail

sales@siko-uk.com

Internet

www.siko-uk.com

SIKO Italia S.r.l.

Via Borromeo, 4
I-20017 Rho MI
Italy

Telephone

+39 02 9390 6329

Telefax

+39 02 93469532

E-Mail

info@siko-italia.com

Internet

www.siko-italia.com

**SIKO Mess- und
Positioniersysteme
GmbH**

Deisrütistrasse 11
8472 Seuzach
Switzerland

Telephone

+41 52 317 46 41

Telefax

+41 52 317 46 42

E-Mail

info@siko-schweiz.ch

Internet

www.siko-schweiz.ch

**SIKO International
Trading (Shanghai)
Co. Ltd.**

Unit A, 26th Floor New
Rainbow Jie Yun Bldg.,
2 Lane 600, Tian Shan
Road, Shanghai/
China 200051

Telephone

+86 21 62 59 47 45

Telefax

+86 21 32 11 04 20

E-Mail

info@siko.cn

Internet

www.siko.cn