

Duff-Norton®

OPERATING, INSPECTION MACHINE SCREW AND MAINTENANCE ACTUATORS INSTRUCTIONS

WITH PARTS LIST

PUBLICATION PART NO. MJ-25-66A

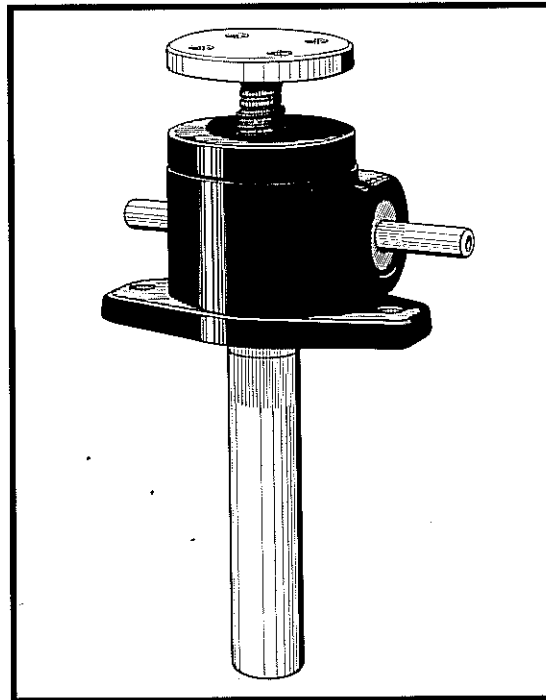

SERIES

1/4-Ton

1/2-TON

1-TON

IMPORTANT — CAUTION

This manual contains important information for the correct installation, operation and maintenance of the equipment described herein. All persons involved in such installation, operation, and maintenance should be thoroughly familiar with the contents. To safeguard against the possibility of personal injury or property damage, follow the recommendations and instructions of this manual and keep it for further reference.

⚠ WARNING

The equipment shown in this manual is intended for industrial use only and should not be used to lift, support, or otherwise transport people.

TABLE OF CONTENTS

		PAGE
SECTION I	GENERAL INFORMATION	
1-1	General	2
1-2	Industrial Use Only	2
1-3	Specifications	2
1-4	Important Precautions	3
1-5	Warranty and Warranty Repair	3
SECTION II	MAINTENANCE	
2-1	Lubrication	4
2-2	Rebuild Procedure	4
2-3	Required Tools	4
2-4	Disassembly	4
2-5	Cleaning	4
2-6	Inspection	5
2-7	Assembly	5
2-8	Anti-Backlash Nut Function	5
2-9	Anti-Backlash Nut Adjustment	5
SECTION III	ILLUSTRATED PARTS LIST	
3-1	General	6
3-2	Parts List — ¼, ½ and 1-Ton Series Machine Screw Actuators	6
FIGURE 3-1	Exploded Illustration ¼, ½ and 1-Ton Series Machine Screw Actuators	7

SECTION I

GENERAL INFORMATION

1-1. General

This manual contains maintenance instructions for Duff-Norton® machine screw actuators. It describes and details procedures for disassembly, cleaning, inspection, rebuilding and assembly of these actuators.

1-2. Industrial Use Only

The machine screw actuators described and illustrated in this manual are intended for industrial use only and should not be used to lift, support or otherwise transport people unless you have a written statement from Duff-Norton Company which authorizes the specific actuator unit, as used in your application, as suitable for moving people.

1-3. Table of Specifications

Actuator No.	Anti-Backlash						
	2555	2625	2501	4555	4625	4501	
Rated Load (lb)	500	1000	2000	500	1000	2000	
Diameter of Lifting Screw (in)	½ .250 Pitch Acme	¾ .125 Pitch Acme	¾ .200 Pitch Acme	½ .250 Pitch Acme	¾ .125 Pitch Acme	¾ .200 Pitch Acme	
Closed Height* (in)	4	4	4½	4	4	5	
Base Size (in)	2¼ × 4	2¼ × 4	2¾ × 5	2¼ × 4	2¼ × 4	2¾ × 5	
Worm Gear Ratios	Std. Ratio	5:1	5:1	5:1	5:1	5:1	
	Optional	-	-	20:1	-	-	20:1
Turns of Worm For 1" Raise	Std. Ratio	20	40	25	20	40	25
	Optional	-	-	100	-	-	100
Maximum H.P. Per Actuator	Std. Ratio	½	½	½	½	½	
	Optional	-	-	½	-	-	¼
Torque at Full Load (in-lbs)	Std. Ratio	13	21	55	15	23	60
	Optional	-	-	25	-	-	27
Actuator Efficiency Rating (%)	Std. Ratio	33	20	24.5	26.5	17.3	21:2
	Optional	-	-	14.0	-	-	11:8
Weight With Base Raise of 6" (lb)	2¼	2¼	5	2½	2½	6	
Weight For Each Additional 1" Raise (lb)	.10	.10	.27	.10	.10	.27	

*Closed heights are for standard upright models and may vary with different screw ends, inverted models or when bellows boot is used.

1-4. Important Precautions

In order to ensure that Duff-Norton machine screw actuators provide good service over a period of years the following precautions should be taken:

1. Select an actuator that has a load rating greater than the maximum load that may be imposed on it.
2. The structure on which the actuators are mounted should have ample strength to carry the maximum load, and should be rigid enough to prevent undue deflection or distortion of the actuator supporting members.
3. It is essential that the actuators be carefully aligned during installation so that the lifting screws are perfectly plumb and the connecting shafts are exactly in line with the worm shafts. After the actuators, shafting, gear boxes, etc., are coupled together, it should be possible to turn the main drive shaft by hand. If there are no signs of binding or misalignment, the actuator system is then ready for normal operation.
4. Machine screw actuators should have a greater raise than is needed in the actual installation. Should it be necessary to operate these actuators at the extreme limits of travel, it should be done cautiously.

CAUTION

Do not allow actuator travel to go beyond catalog closed height of actuator or serious damage to internal mechanism may result. Refer to table of specifications (par. 1-3) for closed height of respective units.

5. The worm shaft speed should not exceed 900 RPM for heavy loads or 1800 RPM for light loads of one-fourth (or less) of the actuator load rating for 500 and 1000 pound rated units. For units with a one-ton load rating, worm shaft speed should not exceed 1800 RPM.
6. The lifting screw should not be permitted to accumulate dust and grit on the threads. If possible, lifting screws should be returned to closed position when not in use.

CAUTION

Where lifting screws are not protected from airborne dirt, dust, etc., bellows boots should be used. Inspect frequently at regular intervals to be certain that a lubricating film is present. Lifting screws should never be run dry.

7. A periodic check of backlash of the lifting screw thread is recommended to check wear of worm gear internal screw threads. The normal backlash of new units equipped with worm gear only is .003 inch on 500 pound units, .007 inch on 1000 pound units and .006 inch on 1-ton units. Backlash of 50 per cent or more of the thread thickness indicates the need to replace the worm gear. Backlash is adjustable in units equipped with an anti-backlash nut, but should not be adjusted below .0005 inch backlash. The worm gear and anti-backlash nut are manufactured to have a clearance between their surfaces of $\frac{1}{2}$ the thread thickness. When adjustments have been made using this clearance, 50 per cent of the thread thickness is gone and replacement is necessary. (See page 5 for a detailed explanation of how the anti-backlash nut functions.)
8. The lubrication procedures for normal and severe service conditions, as described in Section II, paragraph 2-1, should be closely followed.

1-5. Warranty and Warranty Repair

Subject to the conditions stated herein, Duff-Norton will repair or replace, without charge, any parts proven to Duff-Norton's satisfaction to have been defective in material or workmanship. Claims must be made within one year after date of shipment. Duff-Norton will not repair or replace any parts that become inoperative because of improper maintenance, eccentric loading, overloading, chemical or abrasive action, excessive heat, or other abuse.

Equipment and accessories not of Duff-Norton's manufacture are warranted only to the extent that they are warranted by the manufacturer, and only if the claimed defect arose during normal use, applications and service. Equipment which has been altered or modified by anyone without Duff-Norton's authorization is not warranted by Duff-Norton. **EXCEPT AS STATED HEREIN, DUFF-NORTON MAKES NO OTHER WARRANTIES, EXPRESS OR IMPLIED, INCLUDING WARRANTIES OF MERCHANTABILITY AND FITNESS FOR A PARTICULAR PURPOSE.**

If you have any questions concerning warranty repair, please contact Duff-Norton Customer Service.

Authorization for return must be received from the Duff-Norton Company before returning any equipment for inspection or warranty repair.

SECTION II

MAINTENANCE

2-1. Lubrication

Unless otherwise specified, actuators are shipped packed with grease which should be sufficient for one month of normal operation. For normal operation, the actuator should be lubricated once a month using one of the following Extreme Pressure greases or their equivalent:

Socony Mobile Oil Co. Mobilplex E.P. #1
Texaco Texaco E.P. #1
Gulf Oil Corp. Gulf Crown E.P. #1
Shell Oil Co. Shell Alvania E.P. #1

For severe service conditions, the actuators should be lubricated more frequently using one of the above greases (daily to weekly depending on conditions). If duty is heavy, an automatic lubrication system is strongly recommended. If ambient temperatures exceed 200 °F, consult lubricant manufacturers.

CAUTION

Where lifting screws are not protected from airborne dirt, dust, etc., bellows boots should be used. Inspect frequently at regular intervals to be certain that a lubricating film is present. Lifting screws should never be run dry.

2-2. Rebuild Procedure

Duff-Norton recommends the following procedures for assembly and disassembly of machine screw actuators.

1. Tag critical parts to facilitate reassembly.
2. Mark mating surfaces to ensure proper meshing.
3. Clean and lubricate all parts as required.
4. All screws, washers and other small common parts must be replaced if damaged in any way.
5. Replace damaged or frozen lubrication fittings with new ones.

2-3. Required Tools

Common hand tools are all that are normally necessary for proper assembly and disassembly.

2-4. Disassembly (Refer to Figure 3-1)

1. Remove lifting screw (5) from actuator.
2. Remove bottom pipe (4) from shell (3) (upright models) or shell cap (2) (inverted models). For inverted models, remove guide bushing (14) from shell (3).

3. Loosen and remove set screws (1) in shell cap (2) and remove cap from shell (3).

NOTE

It may be necessary to break shell cap loose with a wooden or lead mallet.

4. Remove the top load bearing (7), which may be attached to shell cap (2) or worm gear (6A).

CAUTION

Use only a wooden mallet to tap bearings loose.

5. Remove worm gear (6A) or worm gear and anti-backlash nut assembly (6B) from shell (3).
6. Remove bottom load bearing (8) which may be attached to the shell (3) or worm gear (6).
7. $\frac{1}{4}$ and $\frac{1}{2}$ -ton — remove four set screws (9) from the shell (3) to loosen worm retainer bushings (10). If threaded bushings are used, remove these, using a spanner wrench. 1-ton — remove two retainer rings (17) from worm housing.
8. Remove worm (11), needle bearing (13) and race washers (12) from the shell by striking one end of the worm with a wooden or lead mallet. (Bearing Index No. 18 on 1-ton unit.)
9. Slide off worm retainer bushings (10) and needle bearings (13) or bearing (18).

2-5. Cleaning

1. Use degreasing solvent to remove grease or oil from all parts.

WARNING

Provide adequate ventilation during the use of cleaning agents; avoid prolonged breathing of fumes and contact with skin.

2. Use clean hot water or a soap solution for general cleaning of painted surfaces.
3. Dry parts thoroughly after cleaning.

NOTE

Before installing new parts, remove any rust preventive, protection grease, etc.

2-6. Inspection (Refer to Figure 3-1)

1. Make a visual inspection of shell (3) for broken, cracked or distorted areas. Check threads of all bores for burrs or broken threads.
2. Check shell cap (2), bottom pipe (4), lifting screw (5), worm gear assembly and bushings (10) for burrs or scratches on their working or mating surfaces.
3. Check fit between screw thread and internal thread in worm gear. If fit is excessively loose, replace worm gear (6A) or replace worm gear and nut assembly (6B) as a set.
4. Check small common components (screws, etc.) and replace as required.

2-7. Assembly (Refer to Figure 3-1)

NOTE

Steps 1, 2 and 3 refer to $\frac{1}{4}$ and $\frac{1}{2}$ -ton units. Step 10 refers to 1 ton unit.

1. Slide thrust race (12), needle bearing (13) and another thrust race on each end of worm (11).
2. Position worm (11) in shell (3).
3. Slide bronze worm retainer bushings (10) on both sides of the worm shaft and place them in shell until bushings are positioned to control lateral movement of the worm to about .002 inches. If bushings are the threaded type, the same procedure should be followed except bushing should be threaded into position in the shell. Install four set screws (9) in shell (3). Tighten them down until they seat against bronze retainer bushing (10).
4. Place bottom load bearing (8) into shell (3) — **on 1-ton units**, press bearing race into shell first. Be sure bearing is properly positioned.
5. Install worm gear (6A) or worm gear and nut assembly (6B) in shell (3).
6. Place top load bearing (7) on hub of worm gear (hub of nut on anti-backlash units). Be sure bearing is properly positioned.
7. Fill housing with grease.
8. **1-ton unit** — Install bearing cup into shell cap (2). Install shell cap into shell (3) and screw down until shell cap is tight.

NOTE

Shell cap flange does not necessarily have to bear against top of shell; there will usually be a gap. This should put a slight drag on worm. If worm is hard to run, back off slightly on shell cap.

9. Tighten shell cap set screws (1) to lock cap to shell.

NOTE

If new parts have been installed, it may be necessary to spot drill shell top for these screws.

10. **For one ton unit only** — press in one worm bearing (18), position retainer ring (17) behind this bearing, place other worm bearing on end of worm shaft, insert other worm shaft end through worm housing, tap lightly to position worm and both bearings and snap in second retainer ring.

11. Screw bottom pipe (4) into shell (3) (upright models) or into shell cap (2) (inverted models).
12. Brush lifting screw (5) with a light film of grease and install in actuator. On inverted models, install guide bushing (14) and then install lifting screw.
13. Operate unit to ensure proper functioning of all components prior to installation.

2-8. Anti-Backlash Nut Function

As shown in Figure 2-1, the worm gear (2) and anti-backlash nut (3) are pinned together with guide pins. The threads in the anti-backlash nut work in opposition to the threads in the worm gear as they engage the threads of the lifting screw (1). Adjustment of backlash is made by running down on the shell cap of the actuator. This forces the anti-backlash nut threads into closer contact, reducing clearance and thus reducing backlash.

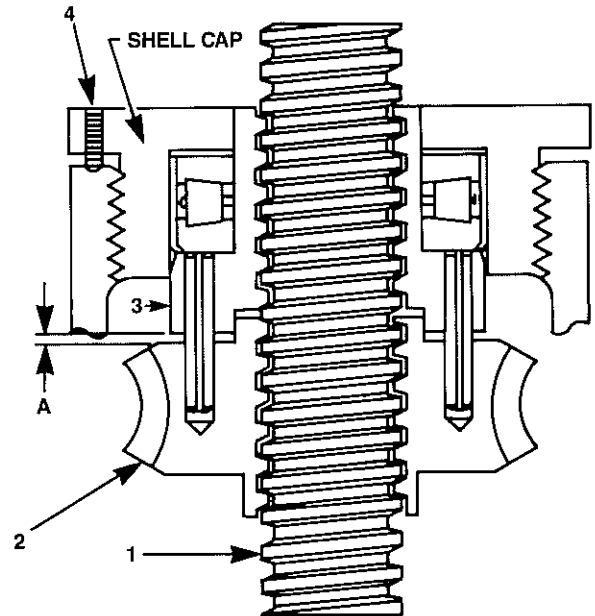

Patent No. 3,323,777

FIGURE 2-1. ANTI-BACKLASH NUT ADJUSTMENT

2-9. Anti-Backlash Nut Adjustment

1. To minimize backlash, remove the two set screws (4) and tighten down on shell cap until the desired backlash is obtained. Respot top of shell through set screw holes, then replace set screws and tighten to prevent shell cap backing off.
2. To avoid binding and excessive wear, do not adjust lifting screw backlash to less than 0.002 inch.
3. The clearance (A) designed into the worm gear and anti-backlash nut set is one-half the thread thickness. When adjustments have been made to use all this clearance replace the worm gear and anti-backlash nut as a set.

SECTION III

ILLUSTRATED PARTS LIST

3-1. General

This section contains an exploded illustration of the ¼, ½, and 1-Ton Series machine screw actuators. The number adjacent to each part on the illustration is the index number. Keyed to this index number on the parts list is the part name.

When ordering parts be sure to include:

1. The nameplate model of your unit.
2. Index number and name of part.

3-2. PARTS LIST FOR ¼, ½ And 1-TON SERIES MACHINE SCREW ACTUATORS

INDEX NO.	PART NAME	QTY. REQ.
1	Screw, Set	2
2	Cap, Shell	1
3	Shell, Unit	1
4	Pipe, Bottom	1
5	Screw Assembly, Lifting	1
6A	Worm Gear	1
6B	Backlash Nut Assembly (Mfg'd and sold in sets only)	1
7	Bearing, Top Load	1
8	Bearing, Bottom Load	1
9*	Screw, Set	4
10*	Bushing, Worm Retainer	2
12*	Thrust Race	4
13*	Bearing, Needle	2
14	Bushing, Guide (Inverted models only)	1
15	Fitting, Grease	1
16	Nameplate	1
17**	Retainer Ring	2
18**	Bearing, Worm	2
19**	Drive Lock Pin, Top Plate	1

* Used on ¼ and ½ ton only.

**Used on 1 ton only

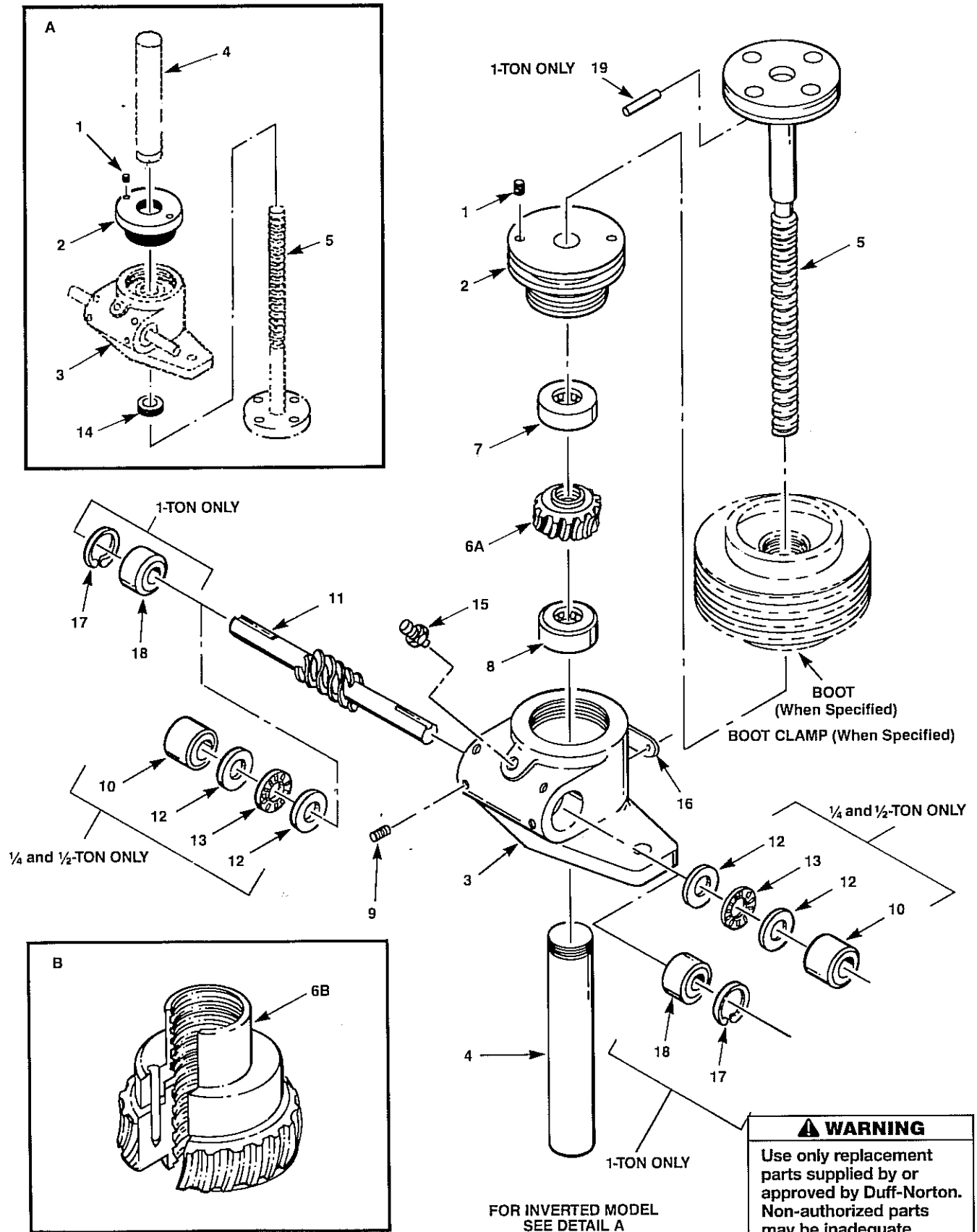
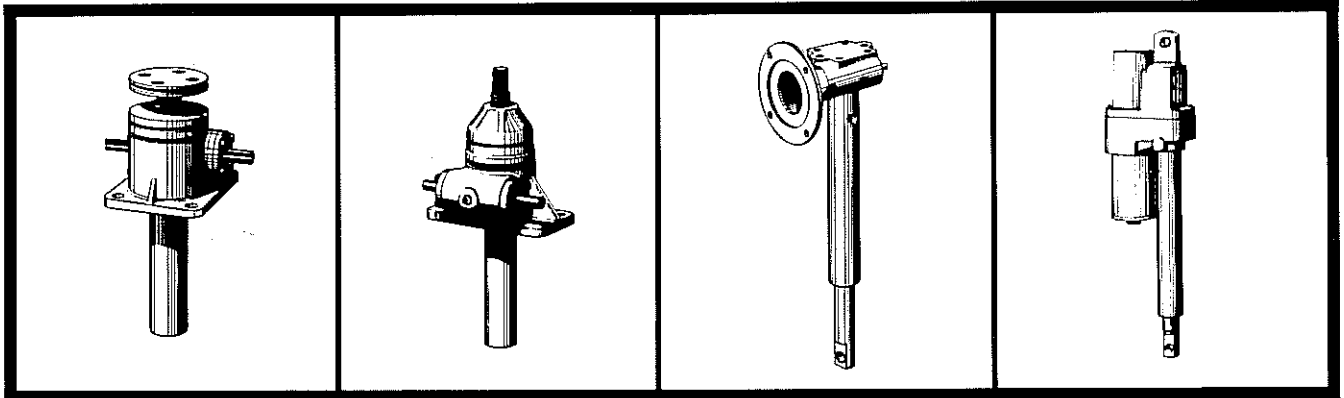

FIGURE 3-1. EXPLODED ILLUSTRATION 1/4, 1/2 And 1-TON SERIES MACHINE SCREW ACTUATORS

DUFF-NORTON OFFERS A COMPLETE LINE OF MECHANICAL AND ELECTROMECHANICAL ACTUATORS FOR PRECISE POSITIONING OF LOADS UP TO 250 TONS.

For reliable motion — in-line or through an arc — Duff-Norton has the right actuator to put your designs in motion. You can select from a comprehensive line of machine screw, ball screw, high-duty cycle, electro-mechanical and modular models to solve your design and production problems.

Duff-Norton® actuators are easy to specify, install and operate. Compact and self-contained, they do not require bothersome selection of individual components nor the attendant maintenance of leaky hydraulic hoses, valves or couplings. They provide many options in meeting a wide range of lifting, pushing, pulling and tensioning requirements.



Machine Screw Actuators. Capacities from ¼ to 250 tons. Worm gear ratios from 5:1 to 50:1. More than 200 standard combinations to choose. Can be operated manually or by gear motor. Used to push, pull, apply pressure, or as linear actuators. Hold loads indefinitely without creep, when not subject to vibration.

Ball Screw Actuators. Capacities from ½ to 50 tons. Ball bearing screw and nut design reduces friction, increases efficiency as much as 70%. Permits linear motion up to 300 in/min @ 1800 rpm worm shaft speed. Available in 40 standard models. Multiple units may be synchronized for uniform raises to 10 feet.

Modular Actuators. Capacities to 2,000 pounds depending on actuator gear ratio and motor horsepower. Engineered for 56 frame motor, C face mounting. Choice of 5:1 or 20:1 gear ratios in rotating screw or translating tube models. Travel lengths to 24 inches. Lift speeds to 170 inches per minute.

Electromechanical Actuators. Capacities to ¾ ton. Choice of 115 VAC or 12 VDC motors for indoor or outdoor applications. Standard raises from 3" to 24". Speeds to 145 in/min. All components sealed in a corrosion-resistant, aluminum alloy die-cast housing. Fully-adjustable limit switches available on some models.

For more information on these or other Duff-Norton® actuators, ask your local distributor or Duff-Norton District Sales Manager for Catalog 172. Or write factory.

WARNING: The equipment shown in this manual is intended for industrial use only and should not be used to lift, support, or otherwise transport people unless you have a written statement from Duff-Norton Company which authorizes the specific actuator unit, as used in your application, as suitable for moving people.

AVAILABLE FROM YOUR LOCAL ACTUATOR DISTRIBUTOR:

Duff-Norton

P.O. Box 7010
Charlotte, NC 28241-7010

Customer Service (704) 588-4610
FAX (704) 588-1994
TELEX 575188

Duff-Norton Manufactures:
Duff-Norton® Actuators • Mechanical Jacks • Rotary Unions • Coffing® Hoists
Duff Lynx® Hoists and Pullers