

6" Diameter x .750 Lead Lifting Screws

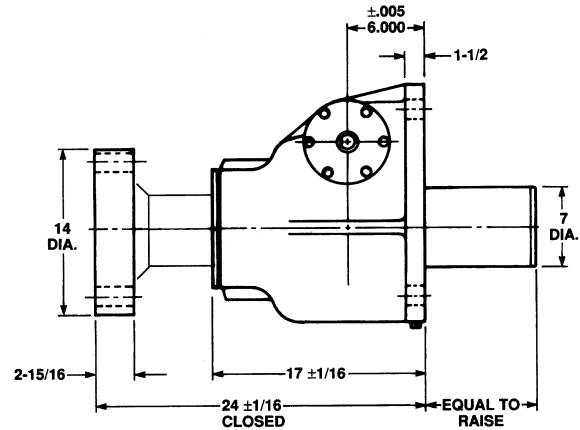

Upright: M-9099

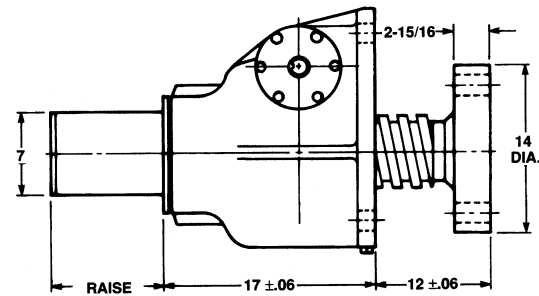
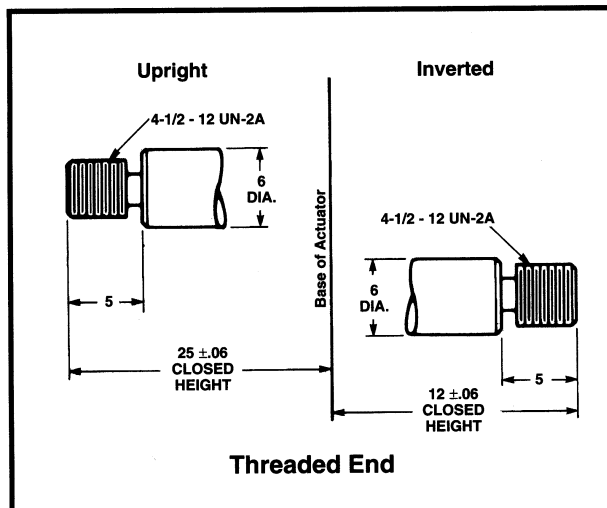

Inverted: M-9098

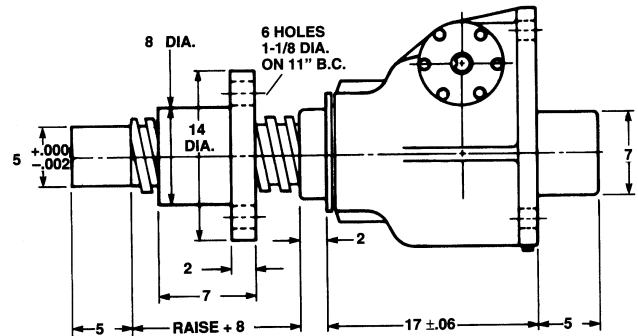
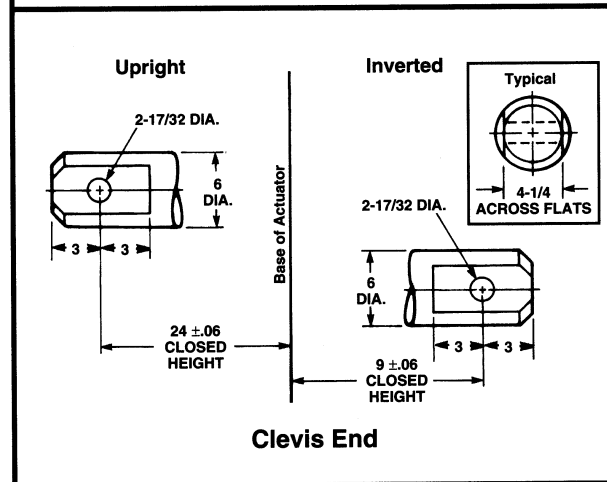

Upright Rotating: UM-9097

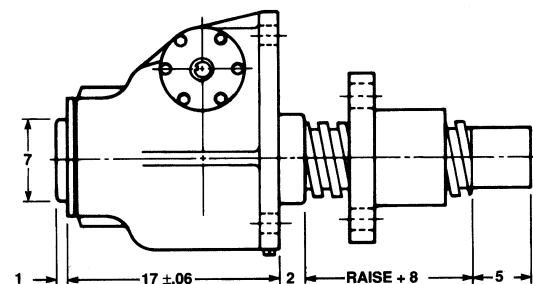

Inverted Rotating: DM-9097

Note: Lifting screw is not keyed. Top should be secured to a lifting member to prevent rotation. When a Bellows Boot is required, see pages 143-144. Dimensions are subject to change without notice.