

Poulies et Accessoires



www.fogex.com

Conformément à la politique SIT S.p.A., pour une amélioration constante de nos produits, les données techniques contenues dans ce catalogue peuvent être modifiées sans préavis.

Les poulies SIT et les produits annexes sont conçus en Italie et fabriqués et / ou contrôlés dans le groupe SIT :

ITALIE: Brembilla / ALLEMAGNE: Brakel / FRANCE: Argenteuil / ESPAGNE: Barcelone / CHINE: Shanghai

Toutes les poulies et les accessoires fabriqués par SIT sont conformes à la réglementation RoHS (RoSH Directive 2011/65 / UE) et à la Directive REACH (1907/2006).

INDEX

POULIES DENTÉES SIT	Pag.
PAS EN POUCES	
Caractéristiques	7
Dimensions des poulies dentées - moyeu plein	8 ÷ 19
Dimensions des poulies dentées - moyeu amovible SER-SIT®	20 ÷ 29
PAS MÉTRIQUE	
Caractéristiques	30
Dimensions des poulies dentées - moyeu plein	31 ÷ 34
TOP DRIVE® HTD	
Caractéristiques	35
Dimensions des poulies dentées - moyeu plein	36 ÷ 42
Dimensions des poulies dentées - moyeu amovible SER-SIT®	43 ÷ 47
SUPER TORQUE	
Caractéristiques	48
Dimensions des poulies dentées - moyeu plein	49 ÷ 53
Dimensions des poulies dentées - moyeu amovible SER-SIT®	54 ÷ 57
FALCON GTR®	
Caractéristiques	58
Dimensions des poulies dentées - moyeu amovible SER-SIT®	59 ÷ 67
EAGLE®	
Caractéristiques	68
Dimensions des poulies dentées - moyeu plein	69 ÷ 73
Dimensions des poulies dentées - moyeu amovible SER-SIT®	74 ÷ 77
EAGLE® aluminum	78 ÷ 82
BARREAUX DENTÉS	
PAS EN POUCES	85
TOP DRIVE® HTD	86
BARREAUX DENTÉS SIT - PAS MÉTRIQUE "T"	87
BARREAUX DENTÉS SIT - PAS MÉTRIQUE "AT"	88
FLASQUES	
Flasques	91 - 92
PLAQUES DE JONCTION SIT	
Plaques de jonction SIT	95
Plaques de jonction brutes SIT	96





POULIES À GORGES TRAPÉZOÏDALES SIT	Pag.
POULIES À GORGES TRAPÉZOÏDALES	
Caractéristiques	99 ÷ 101
Dimensions des poulies à gorges trapézoïdales - moyeu plein	102 ÷ 107
Dimensions des poulies à gorges trapézoïdales - moyeu amovible SER-SIT®	108 ÷ 118
Dimensions des poulies pour moyeux d'assemblage SIT-LOCK® CAL 8	119
SIT-LOCK® CAL 8	120
POULIES RÉGLABLES	
Caractéristiques	123
Dimensions des poulies PR DV - moyeu plein	124
Dimensions des poulies PBR DV f- moyeu amovible SER-SIT®	125
POULIES À VITESSE VARIABLE	
VAR	129
FIXED	130
Plage de vitesse et entraxes des ensembles VAR et FIXED	131 ÷ 133
POULIES POLY-V SIT	
Pag.	
Caractéristiques	137
Dimensions des poulies POLY-V - moyeu amovible SER-SIT®	138 ÷ 146
ACCESSOIRES	
Pag.	
MOYEURS AMOVIBLES SER-SIT®	
Description	149
Caractéristiques	150 - 151
SERLOCK® SIT	
Description	152
Dimensions et performances des types standards	153 - 154
GLISSIÈRES MOTEUR	
Pag.	
GLISSIÈRES MOTEUR	
Glissières moteur	157 ÷ 162
TENSION ET ALIGNEMENT DE LA COURROIE	
Pag.	
TEN-SIT® 2.0	
Ten-Sit® 2.0	164 - 165
LINE-LASER®	
Line-Laser®	166

SIT - Transmissions de puissance, une histoire de passion et de technologie

SIT S.p.A., membre du groupe Scaglia fondé il y a presque 200 ans à Bergame, en Italie, a dédié 50 ans de son histoire à la fabrication et la fourniture de solutions de transmission de puissance. Cette expérience alimente une conception innovante de produits fiables de haute qualité, confirmée par nos certifications ISO 9001, ATEX et ROHS. Avec son mélange gagnant de créativité humaine et de technologie, SIT est reconnue comme un leader de l'industrie des transmissions. Grâce à son réseau de distribution mondial, SIT garantit à ses clients une assistance et une réponse technique pour la conception des transmissions, des gammes complètes en stock, et un service rapide et précis.

SIT S.p.A fabrique et commercialise une large gamme de courroies et de poulies trapézoïdales, Poly-V, des moyeux d'assemblage sans clavette, des pignons à chaînes, des paliers à billes, des réducteurs planétaires, des accouplements à denture, des glissières pour moteurs, en standard ou selon les spécifications techniques de nos clients.



Aujourd'hui

Poulies dentées

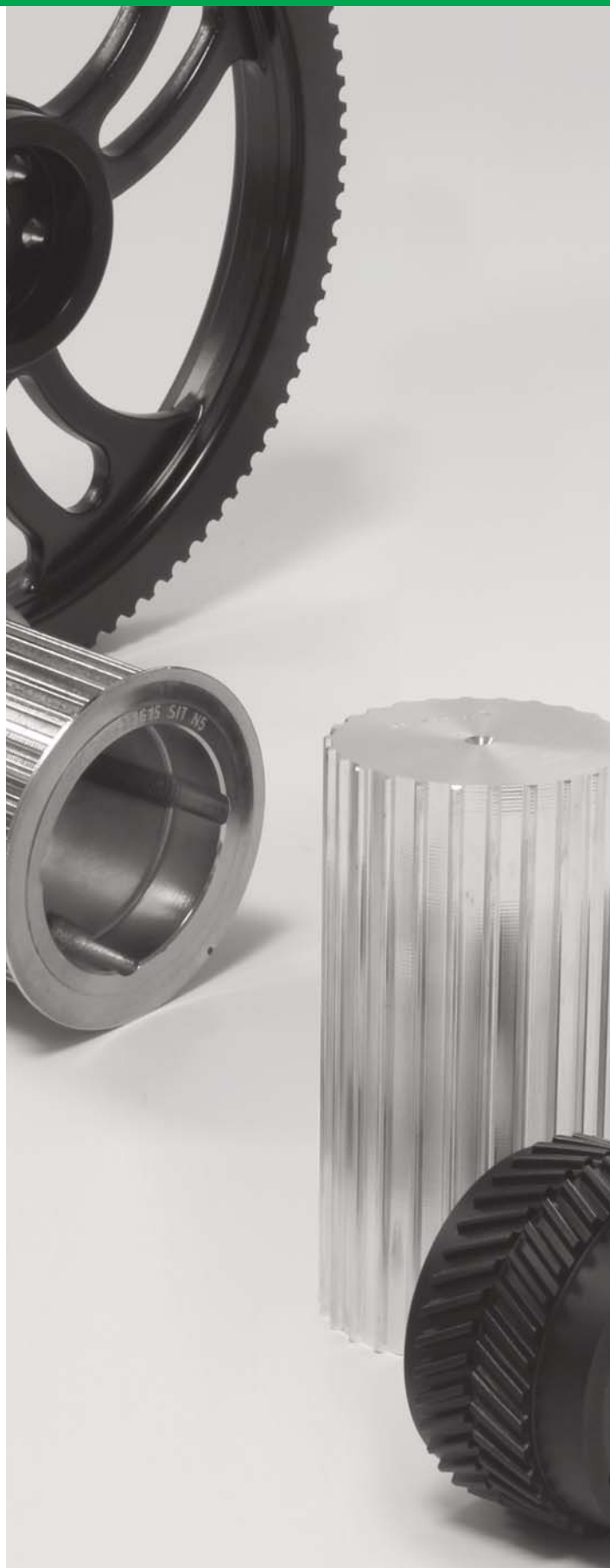

Les poulies synchrones avec pas en pouces sont disponibles en exécution pour moyeu plein et pour assemblage avec des moyeux amovibles SER-SIT®.

Ces types de poulies sont disponibles dans une large gamme de pas et de nombre de dents..

Moyeu plein

Matière : aluminium / fonte / acier.

Finition: phosphatation au manganèse noir (l'aluminium n'est pas traité)

Pas :

- XL
- L
- H
- XH
- XXH



Pour le montage avec moyeux amovibles SER-SIT®

Matière : fonte.

Finition: phosphatation au manganèse noir.

Pas :

- L
- H
- XH



Exécutions spéciales

Sur demande, SIT est capable de concevoir et fabriquer tout type de poulie selon les exigences du client. Pour une vitesse périphérique supérieure à 33 m / s, il est fortement recommandé d'utiliser l'acier comme matière de construction.

$$\text{Vitesse périphérique [m/s]} = \frac{\text{diamètre de la poulie [mm]} \times \text{tr/mn}}{19100}$$

Afin de réduire le poids, les poulies peuvent être fabriquées à partir d'alliages. Dans ce cas, leur durée de vie sera réduite, car le revêtement de courroies en nylon a un effet légèrement abrasif. Cet inconvénient peut être évité par un chromage de la denture de la poulie..

Flasque

Les courroies dentées, lorsqu'elles sont en mouvement, se déplacent légèrement latéralement. Il est donc nécessaire d'utiliser au moins une poulie à flasque pour empêcher la courroie de sortir de la poulie.

Habituellement, afin de réduire les coûts, la poulie à flasque est celle de plus petit diamètre.

Cependant, lorsque la distance des axes est supérieure à 8 fois le diamètre de la petite poulie, ou lorsque la transmission s'effectue par des arbres disposés non horizontalement, les deux poulies doivent avoir des flasques.

TOLÉRANCES

Tolérance du diamètre de la poulie

Diamètre externe [mm]	Tolérances [mm]
jusqu'à 25,4	-0,05 +0,00
de 25,5 à 50,8	-0,08 +0,00
de 50,9 à 102	-0,10 +0,00
de 103 à 178	-0,13 +0,00
de 179 à 305	-0,15 +0,00
de 306 à 509	-0,18 +0,00
de 510 à 761	-0,20 +0,00
de 762 à 1015	-0,23 +0,00
plus de 1016	-0,25 +0,00

Tolérance d'excentration maxi entre l'alésage et le diamètre extérieur

Diamètre externe [mm]	Excentricité totale mesurée [mm]
jusqu'à 203,2	0,13
plus de 203,2	Ajoutez 0,013 pour 25,4 de diamètre

Oscillation latérale ou voilage

Largeur de la poulie	Tolérances
par 100 mm	0,1 mm sans dépasser la tolérance de diamètre extérieur

Revêtement de protection

Toutes les poulies (acier et fonte) sont traitées avec un procédé de phosphatation au manganèse noir qui donne une plus grande résistance contre les agents oxydants. Ce traitement ne modifie pas le profil ou les dimensions des poulies.

Sur demande, SIT peut fournir une large gamme de revêtements spéciaux, liés aux besoins ou à des conditions environnementales critiques.

Note

En raison de l'amélioration constante de nos produits, les données techniques des poulies peuvent faire l'objet de modifications.

Dimensions des poulies dentées, pas en pouces - moyeu plein

Types XL - L - H - XH - XXH



Désignation	PD	40	XL	037
Poulies dentées, pas en pouces - moyeu plein				
Nombre de dents				
pas				
Largeur de la courroie en pouces x 100				

PD ... XL 037

XL

Code	Nb de dents	Type	E [mm]	R [mm]	S [mm]	U [mm]	H [mm]	d [mm]	W [mm]	Y [mm]	Z [mm]	Flasque	Matière
PD10XL037	10	1	23,0	16,17	15,66	-	10,0	-	14,3	25,0	10,7	avec flasque	aluminium
PD11XL037	11	1	23,0	17,79	17,28	-	10,0	-	14,3	25,0	10,7		
PD12XL037	12	1	25,0	19,40	18,89	-	12,0	-	14,3	25,0	10,7		
PD13XL037	13	1	25,0	21,02	20,51	-	12,0	-	14,3	25,0	10,7		
PD14XL037	14	1	28,0	22,64	22,13	-	15,0	-	14,3	25,0	10,7		
PD15XL037	15	1	28,0	24,25	23,74	-	15,0	-	14,3	25,0	10,7		
PD16XL037	16	1	32,0	25,87	25,36	-	17,0	-	14,3	25,0	10,7		
PD17XL037	17	1	32,0	27,49	26,98	-	20,0	-	14,3	25,0	10,7		
PD18XL037	18	1	35,0	29,11	28,60	-	20,0	-	14,3	25,0	10,7		
PD19XL037	19	1	35,0	30,72	30,21	-	20,0	-	14,3	25,0	10,7		
PD20XL037	20	1	38,0	32,34	31,83	-	24,0	-	14,3	25,0	10,7		
PD21XL037	21	1	38,0	33,96	33,45	-	24,0	-	14,3	25,0	10,7		
PD22XL037	22	1	41,0	35,57	35,06	-	27,0	-	14,3	25,0	10,7		
PD24XL037	24	1	44,0	38,81	38,30	-	30,0	-	14,3	25,0	10,7		
PD26XL037	26	1	48,0	42,03	41,53	-	30,0	-	14,3	25,0	10,7		
PD27XL037	27	1	48,0	43,66	43,15	-	32,0	-	14,3	25,0	10,7		
PD28XL037	28	1	51,0	45,28	44,77	-	34,0	-	14,3	25,0	10,7		
PD29XL037	29	1	51,0	46,89	46,38	-	34,0	-	14,3	25,0	10,7		
PD30XL037	30	1	54,0	48,51	48,00	-	38,0	-	14,3	25,0	10,7		
PD32XL037	32	1A	-	51,74	51,23	-	45,0	-	14,3	25,0	10,7		
PD34XL037	34	1A	-	54,98	54,47	-	45,0	-	14,3	25,0	10,7		
PD35XL037	35	1A	-	56,60	56,09	-	45,0	-	14,3	25,0	10,7		
PD36XL037	36	1A	-	58,21	57,70	-	52,0	-	14,3	25,0	10,7		
PD38XL037	38	1A	-	61,45	60,94	-	52,0	-	14,3	25,0	10,7		
PD39XL037	39	1A	-	63,06	62,55	-	52,0	-	14,3	25,0	10,7		
PD40XL037	40	1A	-	64,68	64,17	-	52,0	-	14,3	25,0	10,7		
PD41XL037	41	1A	-	66,30	65,79	-	52,0	-	14,3	25,0	10,7		
PD42XL037	42	1A	-	67,91	67,40	-	52,0	-	14,3	25,0	10,7		
PD43XL037	43	1A	-	69,53	69,02	-	52,0	-	14,3	25,0	10,7		
PD44XL037	44	1A	-	71,15	70,64	-	52,0	-	14,3	25,0	10,7		
PD45XL037	45	1A	-	72,77	72,26	-	52,0	-	14,3	25,0	10,7		
PD46XL037	46	1A	-	74,38	73,87	-	52,0	-	14,3	25,0	10,7		
PD47XL037	47	1A	-	76,00	75,49	-	52,0	-	14,3	25,0	10,7		
PD48XL037	48	1A	-	77,62	77,11	-	52,0	-	14,3	25,0	10,7		
PD49XL037	49	3A	-	79,23	78,72	54,0	52,0	-	14,3	25,0	10,7		
PD52XL037	52	3A	-	84,08	83,57	58,0	52,0	-	14,3	25,0	10,7		
PD56XL037	56	3A	-	90,55	90,04	65,0	52,0	-	14,3	25,0	10,7		
PD57XL037	57	3A	-	92,17	91,66	67,0	52,0	-	14,3	25,0	10,7		
PD58XL037	58	3A	-	93,79	93,28	69,0	52,0	-	14,3	25,0	10,7		
PD59XL037	59	3A	-	95,40	94,89	70,0	52,0	-	14,3	25,0	10,7		
PD60XL037	60	3A	-	97,02	96,51	71,0	52,0	-	14,3	25,0	10,7		
PD68XL037	68	3A	-	109,96	109,45	84,0	52,0	-	14,3	25,0	10,7		
PD69XL037	69	3A	-	111,57	111,06	85,0	52,0	-	14,3	25,0	10,7		
PD70XL037	70	3A	-	113,19	112,68	87,0	52,0	-	14,3	25,0	10,7		
PD71XL037	71	3A	-	114,81	114,30	89,0	52,0	-	14,3	25,0	10,7		
PD72XL037	72	3A	-	116,43	115,92	91,0	52,0	-	14,3	25,0	10,7		

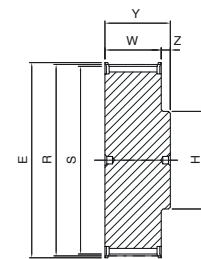

1

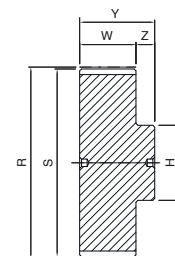

1A

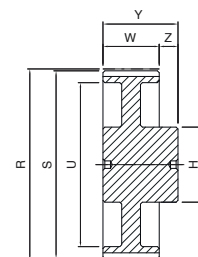

3A

Dimensions des poulies dentées, pas en pouces - moyeu plein



PD ... L 050

L

Code	Nb de dents	Type	E [mm]	R [mm]	S [mm]	U [mm]	H [mm]	d [mm]	W [mm]	Y [mm]	Z [mm]	Flasque	Matière
PD10L050	10	1	37,0	30,32	29,56	-	20,0	-	19,0	30,0	11,0	avec flasque	acier
PD11L050	11	1	37,0	33,35	32,59	-	20,0	-	19,0	30,0	11,0		
PD12L050	12	1	43,0	36,38	35,62	-	27,0	-	19,0	30,0	11,0		
PD13L050	13	1	44,0	39,41	38,65	-	27,0	-	19,0	30,0	11,0		
PD14L050	14	1	48,0	42,45	41,69	-	29,0	-	19,0	30,0	11,0		
PD15L050	15	1	51,0	45,48	44,72	-	32,0	-	19,0	30,0	11,0		
PD16L050	16	1	54,0	48,51	47,75	-	37,0	-	19,0	30,0	11,0		
PD17L050	17	1	57,0	51,54	50,78	-	37,0	-	19,0	30,0	11,0		
PD18L050	18	1	60,0	54,57	53,81	-	41,0	-	19,0	30,0	11,0		
PD19L050	19	1	64,0	57,61	56,84	-	41,0	-	19,0	30,0	11,0		
PD20L050	20	1	66,5	60,64	59,88	-	47,0	-	19,0	30,0	11,0		
PD21L050	21	1	70,0	63,67	62,91	-	47,0	-	19,0	30,0	11,0		
PD22L050	22	1	75,0	66,70	65,94	-	50,0	-	19,0	30,0	11,0		
PD23L050	24	1	79,0	69,73	68,97	-	50,0	-	19,0	30,0	11,0		
PD24L050	26	1	79,0	72,77	72,01	-	55,0	-	19,0	32,0	13,0		
PD25L050	25	1	82,5	75,80	75,04	-	58,0	-	19,0	32,0	13,0		
PD26L050	26	1	86,0	78,83	78,07	-	64,0	-	19,0	32,0	13,0		
PD27L050	27	1	86,0	81,86	81,10	-	64,0	-	19,0	32,0	13,0		
PD28L050	28	1	91,0	84,89	84,13	-	70,0	-	19,0	32,0	13,0		
PD29L050	29	1	94,0	87,93	87,16	-	70,0	-	19,0	32,0	13,0		
PD30L050	30	1	97,0	90,96	90,20	-	72,0	-	19,0	34,0	15,0		
PD32L050	32	1	102,0	97,02	96,26	-	75,0	-	19,0	34,0	15,0		
PD33L050	33	1	106,0	100,05	99,29	-	80,0	-	19,0	34,0	15,0		
PD34L050	34	1	112,0	103,08	102,32	-	85,0	-	19,0	34,0	15,0		
PD35L050	35	1	112,0	106,12	105,35	-	88,0	-	19,0	34,0	15,0		
PD36L050	36	1	115,0	109,15	108,39	-	88,0	-	19,0	34,0	15,0		
PD40L050	40	3	128,0	121,28	120,52	100,0	68,0	11,0	19,0	34,0	15,0		
PD41L050	41	3	128,0	124,31	123,55	103,0	68,0	11,0	19,0	34,0	15,0		
PD42L050	42	3	135,0	127,34	126,58	106,0	68,0	11,0	19,0	34,0	15,0		
PD44L050	44	3	142,0	133,40	132,64	112,0	68,0	11,0	19,0	34,0	15,0		
PD45L050	45	3	142,0	136,44	135,67	115,0	68,0	11,0	19,0	34,0	15,0		
PD47L050	47	3	150,0	142,50	141,74	121,0	68,0	11,0	19,0	34,0	15,0		
PD48L050	48	3	150,0	145,53	144,77	124,0	68,0	11,0	19,0	46,0	27,0		
PD49L050	49	3A	-	148,56	147,80	127,0	68,0	12,0	19,0	46,0	27,0		
PD50L050	50	3A	-	151,60	150,83	130,0	68,0	12,0	19,0	46,0	27,0		
PD52L050	52	3A	-	157,66	156,90	136,0	68,0	12,0	19,0	46,0	27,0		
PD56L050	56	3A	-	169,79	169,02	139,0	68,0	12,0	19,0	46,0	27,0		
PD57L050	57	3A	-	172,82	172,06	152,0	68,0	12,0	19,0	46,0	27,0		
PD60L050	60	3A	-	181,91	181,15	160,0	68,0	12,0	19,0	46,0	27,0		
PD65L050	65	3A	-	197,07	196,31	176,0	68,0	12,0	19,0	46,0	27,0		
PD66L050	66	3A	-	200,11	199,34	179,0	68,0	12,0	19,0	46,0	27,0		
PD72L050	72	3A	-	218,30	217,54	197,0	75,0	12,0	19,0	46,0	27,0		
PD84L050	84	3A	-	254,68	253,92	233,0	75,0	12,0	19,0	46,0	27,0		
PD90L050	90	3A	-	272,87	272,11	252,0	75,0	12,0	19,0	46,0	27,0		
PD96L050	96	3A	-	291,06	290,30	270,0	80,0	12,0	19,0	46,0	27,0		
PD120L050	120	5A	-	363,83	363,07	342,0	85,0	18,0	19,0	46,0	27,0		

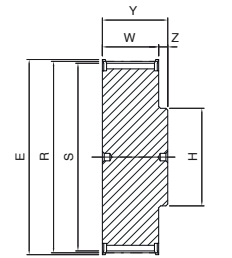

1

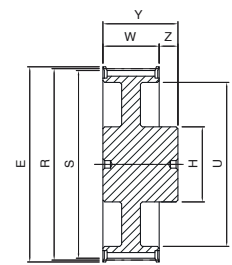

3*

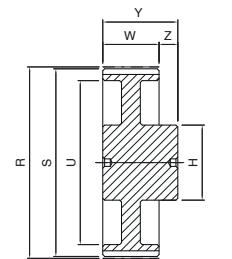

3A*

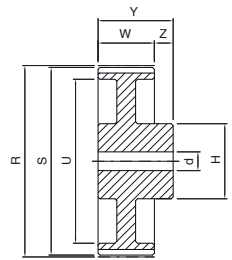

5A

* = Un pré-alésage, de diamètre maximal «d», peut être présent.

Dimensions des poulies dentées, pas en pouces - moyeu plein



PD ... L 075

L

Code	Nb de dents	Type	E [mm]	R [mm]	S [mm]	U [mm]	H [mm]	d [mm]	W [mm]	Y [mm]	Z [mm]	Flasque	Matière
PD10L075	10	1	37,0	30,32	29,56	-	20,0	-	25,4	38,0	12,6	avec flasque	acier
PD11L075	11	1	37,0	33,35	32,59	-	20,0	-	25,4	38,0	12,6		
PD12L075	12	1	43,0	36,38	35,62	-	27,0	-	25,4	38,0	12,6		
PD13L075	13	1	44,0	39,41	38,65	-	27,0	-	25,4	38,0	12,6		
PD14L075	14	1	48,0	42,45	41,69	-	29,0	-	25,4	38,0	12,6		
PD15L075	15	1	51,0	45,48	44,72	-	32,0	-	25,4	38,0	12,6		
PD16L075	16	1	54,0	48,51	47,75	-	37,0	-	25,4	38,0	12,6		
PD17L075	17	1	57,0	51,54	50,78	-	37,0	-	25,4	38,0	12,6		
PD18L075	18	1	60,0	54,57	53,81	-	41,0	-	25,4	38,0	12,6		
PD19L075	19	1	64,0	57,61	56,84	-	41,0	-	25,4	38,0	12,6		
PD20L075	20	1	66,5	60,64	59,88	-	47,0	-	25,4	38,0	12,6		
PD21L075	21	1	70,0	63,67	62,91	-	47,0	-	25,4	38,0	12,6		
PD22L075	22	1	75,0	66,70	65,94	-	50,0	-	25,4	38,0	12,6		
PD23L075	23	1	79,0	69,73	68,97	-	50,0	-	25,4	38,0	12,6		
PD24L075	24	1	79,0	72,77	72,01	-	57,0	-	25,4	38,0	12,6		
PD25L075	25	1	83,0	75,80	75,04	-	58,0	-	25,4	38,0	12,6		
PD26L075	26	1	87,0	78,83	78,07	-	64,0	-	25,4	38,0	12,6		
PD27L075	27	1	87,0	81,86	81,10	-	64,0	-	25,4	38,0	12,6		
PD28L075	28	1	91,0	84,89	84,13	-	70,0	-	25,4	38,0	12,6		
PD29L075	29	1	93,0	87,93	87,16	-	70,0	-	25,4	38,0	12,6		
PD30L075	30	1	97,0	90,96	90,20	-	72,0	-	25,4	38,0	12,6		
PD32L075	32	1	102,0	97,02	96,26	-	75,0	-	25,4	38,0	12,6		
PD33L075	33	1	106,0	100,05	99,29	-	80,0	-	25,4	38,0	12,6		
PD34L075	34	1	112,0	103,08	102,32	-	85,0	-	25,4	38,0	12,6		
PD35L075	35	1	112,0	106,12	105,35	-	88,0	-	25,4	38,0	12,6		
PD36L075	36	1	128,0	109,15	108,39	-	88,0	-	25,4	38,0	12,6		
PD40L075	40	3	128,0	121,28	120,52	100,0	68,0	11,0	25,4	38,0	12,6		
PD41L075	41	3	128,0	124,31	123,55	103,0	68,0	11,0	25,4	38,0	12,6		
PD42L075	42	3	135,0	127,34	126,58	106,0	68,0	11,0	25,4	38,0	12,6		
PD44L075	44	3	142,0	133,40	132,64	112,0	68,0	11,0	25,4	38,0	12,6		
PD45L075	45	3	150,0	136,44	135,67	115,0	68,0	11,0	25,4	38,0	12,6		
PD47L075	47	3	150,0	142,50	141,74	121,0	68,0	11,0	25,4	38,0	12,6		
PD48L075	48	3	150,0	145,53	144,77	124,0	68,0	11,0	25,4	48,0	22,6		
PD49L075	49	3A	-	148,56	147,80	127,0	68,0	12,0	25,4	48,0	22,6		
PD50L075	50	3A	-	151,60	150,83	130,0	68,0	12,0	25,4	48,0	22,6		
PD52L075	52	3A	-	157,66	156,90	136,0	68,0	12,0	25,4	48,0	22,6		
PD56L075	56	3A	-	169,79	169,02	139,0	68,0	12,0	25,4	48,0	22,6		
PD57L075	57	3A	-	172,82	172,06	152,0	68,0	12,0	25,4	48,0	22,6		
PD60L075	60	3A	-	181,91	181,15	160,0	68,0	12,0	25,4	48,0	22,6		
PD65L075	65	3A	-	197,07	196,31	176,0	68,0	12,0	25,4	48,0	22,6		
PD66L075	66	3A	-	200,11	199,34	179,0	68,0	12,0	25,4	48,0	22,6		
PD72L075	72	3A	-	218,30	217,54	197,0	75,0	12,0	25,4	48,0	22,6		
PD84L075	84	3A	-	254,68	253,92	233,0	75,0	12,0	25,4	48,0	22,6		
PD90L075	90	3A	-	272,87	272,11	252,0	75,0	12,0	25,4	48,0	22,6		
PD96L075	96	3A	-	291,06	290,30	270,0	80,0	12,0	25,4	48,0	22,6		
PD120L075	120	5A	-	363,83	363,07	342,0	85,0	18,0	25,4	48,0	22,6		

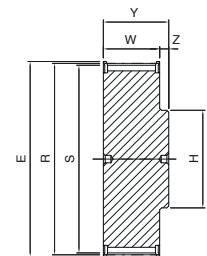

1

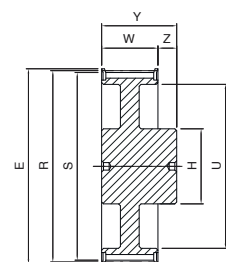

3*

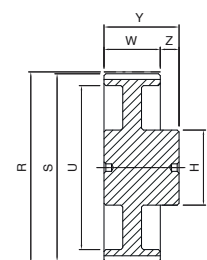

3A*

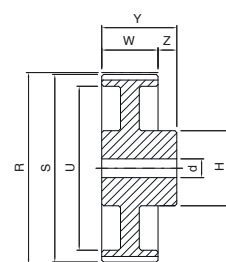

5A

* = Un pré-alésage, de diamètre maximal «d», peut être présent.

Dimensions des poulies dentées, pas en pouces - moyeu plein



PD ... L 100

Code	Nb de dents	Type	E [mm]	R [mm]	S [mm]	U [mm]	H [mm]	d [mm]	W [mm]	Y [mm]	Z [mm]	Flasque	Matière
PD10L100	10	1	37,0	30,32	29,56	-	20,0	-	32,0	46,0	14,0	avec flasque	acier
PD11L100	11	1	37,0	33,35	32,59	-	20,0	-	32,0	46,0	14,0		
PD12L100	12	1	43,0	36,38	35,62	-	27,0	-	32,0	46,0	14,0		
PD13L100	13	1	44,0	39,41	38,65	-	27,0	-	32,0	46,0	14,0		
PD14L100	14	1	48,0	42,45	41,69	-	29,0	-	32,0	46,0	14,0		
PD15L100	15	1	51,0	45,48	44,72	-	32,0	-	32,0	46,0	14,0		
PD16L100	16	1	54,0	48,51	47,75	-	37,0	-	32,0	46,0	14,0		
PD17L100	17	1	57,0	51,54	50,78	-	37,0	-	32,0	46,0	14,0		
PD18L100	18	1	60,0	54,57	53,81	-	41,0	-	32,0	46,0	14,0		
PD19L100	19	1	64,0	57,61	56,84	-	41,0	-	32,0	46,0	14,0		
PD20L100	20	1	66,5	60,64	59,88	-	47,0	-	32,0	46,0	14,0		
PD21L100	21	1	70,0	63,67	62,91	-	47,0	-	32,0	46,0	14,0		
PD22L100	22	1	75,0	66,70	65,94	-	50,0	-	32,0	46,0	14,0		
PD23L100	23	1	79,0	69,73	68,97	-	50,0	-	32,0	46,0	14,0		
PD24L100	24	1	79,0	72,77	72,01	-	57,0	-	32,0	46,0	14,0		
PD25L100	25	1	82,5	75,80	75,04	-	58,0	-	32,0	46,0	14,0		
PD26L100	26	1	86,0	78,83	78,07	-	64,0	-	32,0	46,0	14,0		
PD27L100	27	1	86,0	81,86	81,10	-	64,0	-	32,0	46,0	14,0		
PD28L100	28	1	91,0	84,89	84,13	-	70,0	-	32,0	46,0	14,0		
PD29L100	29	1	93,0	87,93	87,16	-	70,0	-	32,0	46,0	14,0		
PD30L100	30	1	97,0	90,96	90,20	-	72,0	-	32,0	46,0	14,0		
PD32L100	32	1	102,0	97,02	96,26	-	75,0	-	32,0	46,0	14,0		
PD33L100	33	1	106,0	100,05	99,29	-	80,0	-	32,0	46,0	14,0		
PD34L100	34	1	112,0	103,08	102,32	-	85,0	-	32,0	46,0	14,0		
PD35L100	35	1	112,0	106,12	105,35	-	88,0	-	32,0	46,0	14,0		
PD36L100	36	1	115,0	109,15	108,39	-	88,0	-	32,0	46,0	14,0		
PD40L100	40	3	128,0	121,28	120,52	100,0	68,0	11,0	32,0	46,0	14,0		
PD41L100	41	3	128,0	124,31	123,55	103,0	68,0	11,0	32,0	46,0	14,0		
PD42L100	42	3	135,0	127,34	126,58	106,0	68,0	11,0	32,0	46,0	14,0		
PD44L100	44	3	142,0	133,40	132,64	112,0	68,0	11,0	32,0	46,0	14,0		
PD45L100	45	3	142,0	136,44	135,67	115,0	68,0	11,0	32,0	46,0	14,0		
PD47L100	47	3	150,0	142,50	141,74	121,0	68,0	11,0	32,0	46,0	14,0		
PD48L100	48	3	150,0	145,53	144,77	124,0	68,0	11,0	32,0	50,0	18,0		
PD49L100	49	3A	-	148,56	147,80	127,0	68,0	12,0	32,0	50,0	18,0		
PD50L100	50	3A	-	151,60	150,83	130,0	68,0	12,0	32,0	50,0	18,0		
PD52L100	52	3A	-	157,66	156,90	136,0	68,0	12,0	32,0	50,0	18,0		
PD56L100	56	3A	-	169,79	169,02	139,0	68,0	12,0	32,0	50,0	18,0		
PD57L100	57	3A	-	172,82	172,06	152,0	68,0	12,0	32,0	50,0	18,0		
PD60L100	60	3A	-	181,91	181,15	160,0	75,0	12,0	32,0	54,0	22,0		
PD65L100	65	3A	-	197,07	196,31	176,0	75,0	12,0	32,0	54,0	22,0		
PD66L100	66	3A	-	200,11	199,34	179,0	75,0	12,0	32,0	54,0	22,0		
PD72L100	72	3A	-	218,30	217,54	197,0	75,0	12,0	32,0	54,0	22,0		
PD84L100	84	3A	-	254,68	253,92	233,0	80,0	12,0	32,0	54,0	22,0		
PD90L100	90	3A	-	272,87	272,11	252,0	80,0	12,0	32,0	54,0	22,0		
PD96L100	96	3A	-	291,06	290,30	270,0	80,0	12,0	32,0	54,0	22,0		
PD120L100	120	5A	-	363,83	363,07	342,0	90,0	18,0	32,0	54,0	22,0		

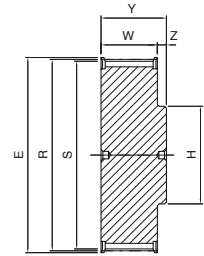

1

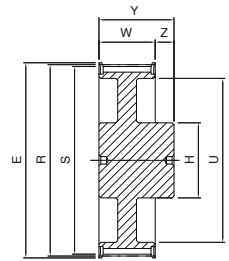

3*

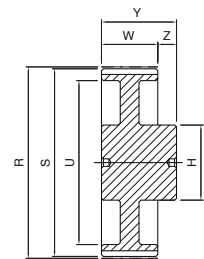

3A*

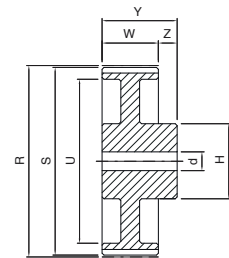

5A

* = Un pré-alésage, de diamètre maximal «d», peut être présent.

Dimensions des poulies dentées, pas en pouces - moyeu plein



PD ... H 075

H

Code	Nb de dents	Type	E [mm]	R [mm]	S [mm]	U [mm]	H [mm]	d [mm]	W [mm]	Y [mm]	Z [mm]	Flasque	Matière
PD14H075	14	1	64,0	56,60	55,23	-	40,0	-	25,4	38,0	12,6	avec flasque	acier
PD15H075	15	1	66,5	60,64	59,27	-	45,0	-	25,4	38,0	12,6		
PD16H075	16	1	70,0	64,68	63,31	-	47,0	-	25,4	38,0	12,6		
PD17H075	17	1	75,0	68,72	67,35	-	49,0	-	25,4	38,0	12,6		
PD18H075	18	1	79,0	72,77	71,40	-	57,0	-	25,4	38,0	12,6		
PD19H075	19	1	82,5	76,81	75,44	-	60,0	-	25,4	38,0	12,6		
PD20H075	20	1	87,0	80,85	79,48	-	64,0	-	25,4	38,0	12,6		
PD21H075	21	1	91,0	84,89	83,52	-	64,0	-	25,4	38,0	12,6		
PD22H075	22	1	94,0	88,94	87,57	-	70,0	-	25,4	38,0	12,6		
PD23H075	23	1	97,0	92,98	91,61	-	72,0	-	25,4	38,0	12,6		
PD24H075	24	1	102,0	97,02	95,65	-	80,0	-	25,4	38,0	12,6		
PD25H075	25	1	106,0	101,06	99,69	-	80,0	-	25,4	38,0	12,6		
PD26H075	26	1	112,0	105,11	103,74	-	85,0	-	25,4	38,0	12,6		
PD27H075	27	1	115,0	109,15	107,78	-	88,0	-	25,4	38,0	12,6		
PD28H075	28	1	120,0	113,19	111,92	-	94,0	-	25,4	38,0	12,6		
PD29H075	29	1	120,0	117,23	115,86	-	96,0	-	25,4	38,0	12,6		
PD30H075	30	1	128,0	121,28	119,91	-	104,0	-	25,4	38,0	12,6		
PD32H075	32	1	135,0	129,36	127,99	-	112,0	-	25,4	38,0	12,6		
PD33H075	33	1	142,0	133,40	132,03	-	112,0	-	25,4	38,0	12,6		
PD34H075	34	1	142,0	137,45	136,08	-	118,0	-	25,4	38,0	12,6		
PD35H075	35	3	150,0	141,49	140,12	118,0	68,0	11,0	25,4	48,0	22,6		
PD36H075	36	3	150,0	145,53	144,16	118,0	68,0	11,0	25,4	48,0	22,6		
PD38H075	38	3	158,0	153,62	152,25	126,0	68,0	11,0	25,4	48,0	22,6		
PD40H075	40	3	168,0	161,70	160,33	134,0	68,0	11,0	25,4	48,0	22,6		
PD44H075	44	3	184,0	177,87	176,50	150,0	68,0	12,0	25,4	48,0	22,6		
PD45H075	45	3	192,0	181,91	180,54	154,0	68,0	12,0	25,4	48,0	22,6		
PD48H075	48	3	200,0	194,04	192,67	166,0	68,0	12,0	25,4	48,0	22,6		
PD49H075	49	3A	-	198,08	196,71	170,0	68,0	12,0	25,4	48,0	22,6		
PD50H075	50	3A	-	202,13	200,76	174,0	68,0	12,0	25,4	48,0	22,6		
PD52H075	52	3A	-	210,21	208,84	182,0	75,0	19,0	25,4	48,0	22,6		
PD60H075	60	3A	-	242,55	241,18	215,0	75,0	19,0	25,4	48,0	22,6		
PD70H075	70	3A	-	282,98	281,61	255,0	75,0	19,0	25,4	48,0	22,6		
PD72H075	72	3A	-	291,06	289,69	263,0	80,0	19,0	25,4	48,0	22,6		
PD82H075	82	5A	-	331,49	330,12	304,0	80,0	19,0	25,4	55,0	29,6		
PD84H075	84	5A	-	339,57	338,20	312,0	90,0	19,0	25,4	55,0	29,6		
PD94H075	94	5A	-	380,00	378,63	352,0	90,0	19,0	25,4	55,0	29,6		
PD96H075	96	5A	-	388,08	386,71	360,0	100,0	19,0	25,4	55,0	29,6		
PD106H075	106	5A	-	428,51	427,14	401,0	100,0	19,0	25,4	55,0	29,6		
PD116H075	116	5A	-	468,93	467,56	441,0	100,0	19,0	25,4	55,0	29,6		
PD118H075	118	5A	-	477,02	475,65	449,0	100,0	19,0	25,4	55,0	29,6		
PD120H075	120	5A	-	485,10	483,73	458,0	100,0	19,0	25,4	55,0	29,6		
PD150H075	150	5A	-	606,38	605,01	579,0	100,0	19,0	25,4	55,0	29,6		
PD152H075	152	5A	-	614,46	613,09	587,0	100,0	19,0	25,4	55,0	29,6		
PD154H075	154	5A	-	622,55	621,17	595,0	100,0	19,0	25,4	55,0	29,6		
PD156H075	156	5A	-	630,63	629,26	603,0	120,0	19,0	25,4	55,0	29,6		

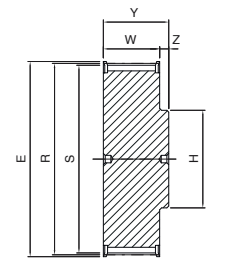

1

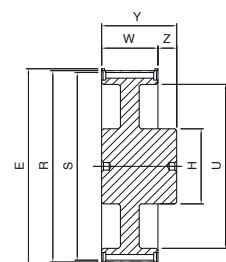

3*

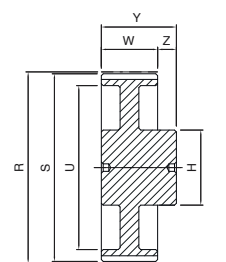

3A*

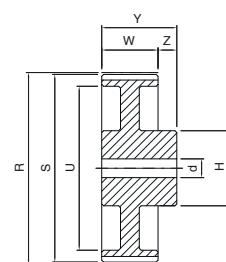

5A

* = Un pré-alésage, de diamètre maximal «d», peut être présent.

Dimensions des poulies dentées, pas en pouces - moyeu plein



PD ... H 100

H

Code	Nb de dents	Type	E [mm]	R [mm]	S [mm]	U [mm]	H [mm]	d [mm]	W [mm]	Y [mm]	Z [mm]	Flasque	Matière
PD14H100	14	1	64,0	56,60	55,23	-	40,0	-	33,3	44,0	10,7	avec flasque	acier
PD15H100	15	1	66,5	60,64	59,27	-	45,0	-	33,3	44,0	10,7		
PD16H100	16	1	70,0	64,68	63,31	-	47,0	-	33,3	44,0	10,7		
PD17H100	17	1	75,0	68,72	67,35	-	49,0	-	33,3	44,0	10,7		
PD18H100	18	1	79,0	72,77	71,40	-	57,0	-	33,3	44,0	10,7		
PD19H100	19	1	82,5	76,81	75,44	-	60,0	-	33,3	44,0	10,7		
PD20H100	20	1	87,0	80,85	79,48	-	64,0	-	33,3	44,0	10,7		
PD21H100	21	1	91,0	84,89	83,52	-	64,0	-	33,3	44,0	10,7		
PD22H100	22	1	94,0	88,94	87,57	-	70,0	-	33,3	44,0	10,7		
PD23H100	23	1	97,0	92,98	91,61	-	72,0	-	33,3	44,0	10,7		
PD24H100	24	1	102,0	97,02	95,65	-	80,0	-	33,3	44,0	10,7		
PD25H100	25	1	106,0	101,06	99,69	-	80,0	-	33,3	44,0	10,7		
PD26H100	26	1	112,0	105,11	103,74	-	85,0	-	33,3	44,0	10,7		
PD27H100	27	1	115,0	109,15	107,78	-	88,0	-	33,3	44,0	10,7		
PD28H100	28	1	120,0	113,19	111,92	-	94,0	-	33,3	48,0	14,7		
PD29H100	29	1	120,0	117,23	115,86	-	96,0	-	33,3	48,0	14,7		
PD30H100	30	1	128,0	121,28	119,91	-	104,0	-	33,3	50,0	16,7		
PD32H100	32	1	135,0	129,36	127,99	-	112,0	-	33,3	52,0	18,7		
PD33H100	33	1	142,0	133,40	132,03	-	112,0	-	33,3	52,0	18,7		
PD34H100	34	1	142,0	137,45	136,08	-	118,0	-	33,3	52,0	18,7		
PD35H100	35	3	150,0	141,49	140,12	118,0	75,0	12,0	33,3	52,0	18,7		
PD36H100	36	3	150,0	145,53	144,16	118,0	75,0	12,0	33,3	52,0	18,7		
PD38H100	38	3	158,0	153,62	152,25	126,0	75,0	12,0	33,3	52,0	18,7		
PD40H100	40	3	168,0	161,70	160,33	134,0	75,0	12,0	33,3	54,0	20,7		
PD44H100	44	3	184,0	177,87	176,50	150,0	75,0	12,0	33,3	54,0	20,7		
PD45H100	45	3	192,0	181,91	180,54	154,0	7,05	12,0	33,3	54,0	20,7		
PD48H100	48	3	200,0	194,04	192,67	166,0	75,0	12,0	33,3	60,0	26,7		
PD49H100	49	3A	-	198,08	196,71	170,0	75,0	12,0	33,3	60,0	26,7		
PD50H100	50	3A	-	202,13	200,76	174,0	75,0	18,0	33,3	60,0	26,7		
PD52H100	52	3A	-	210,21	208,84	182,0	75,0	18,0	33,3	60,0	26,7		
PD60H100	60	3A	-	242,55	241,18	215,0	80,0	18,0	33,3	60,0	26,7		
PD70H100	70	3A	-	282,98	281,61	255,0	80,0	18,0	33,3	60,0	26,7		
PD72H100	72	3A	-	291,06	289,69	263,0	80,0	18,0	33,3	60,0	26,7		
PD82H100	82	5A	-	331,49	330,12	304,0	80,0	18,0	33,3	60,0	26,7		
PD84H100	84	5A	-	339,57	338,20	312,0	90,0	18,0	33,3	60,0	26,7		
PD94H100	94	5A	-	380,00	378,63	352,0	90,0	18,0	33,3	60,0	26,7		
PD96H100	96	5A	-	388,08	386,71	360,0	100,0	18,0	33,3	60,0	26,7		
PD106H100	106	5A	-	428,51	427,14	401,0	100,0	18,0	33,3	60,0	26,7		
PD116H100	116	5A	-	468,93	467,56	441,0	100,0	18,0	33,3	60,0	26,7		
PD118H100	118	5A	-	477,02	475,65	449,0	100,0	18,0	33,3	60,0	26,7		
PD120H100	120	5A	-	485,10	483,73	458,0	100,0	18,0	33,3	60,0	26,7		
PD150H100	150	5A	-	606,38	605,01	579,0	100,0	18,0	33,3	60,0	26,7		
PD152H100	152	5A	-	614,46	613,09	587,0	100,0	18,0	33,3	60,0	26,7		
PD154H100	154	5A	-	622,55	621,17	595,0	100,0	18,0	33,3	60,0	26,7		
PD156H100	156	5A	-	630,63	629,26	603,0	120,0	18,0	33,3	60,0	26,7		

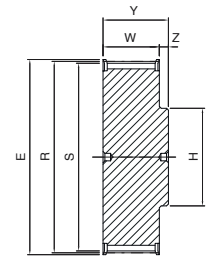

1

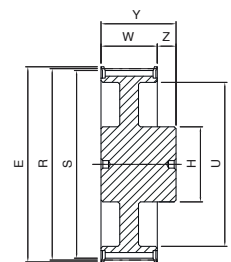

3*

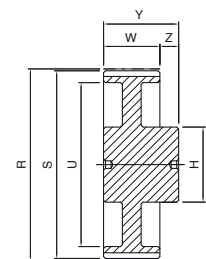

3A*

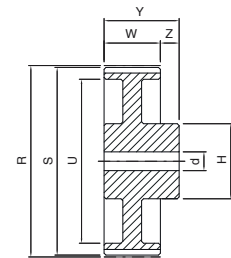

5A

* = Un pré-alésage, de diamètre maximal «d», peut être présent.

Dimensions des poulies dentées, pas en pouces - moyeu plein



PD ... H 150

H

Code	Nb de dents	Type	E [mm]	R [mm]	S [mm]	U [mm]	H [mm]	d [mm]	W [mm]	Y [mm]	Z [mm]	Flasque	Matière
PD14H150	14	1	64,0	56,60	55,23	-	40,0	-	46,0	58,0	12,0	avec flasque	acier
PD15H150	15	1	66,5	60,64	59,27	-	45,0	-	46,0	58,0	12,0		
PD16H150	16	1	70,0	64,68	63,31	-	47,0	-	46,0	58,0	12,0		
PD17H150	17	1	75,0	68,72	67,35	-	49,0	-	46,0	58,0	12,0		
PD18H150	18	1	79,0	72,77	71,40	-	57,0	-	46,0	58,0	12,0		
PD19H150	19	1	82,5	76,81	75,44	-	60,0	-	46,0	58,0	12,0		
PD20H150	20	1	87,0	80,85	79,48	-	64,0	-	46,0	58,0	12,0		
PD21H150	21	1	91,0	84,89	83,52	-	64,0	-	46,0	58,0	12,0		
PD22H150	22	1	94,0	88,94	87,57	-	70,0	-	46,0	58,0	12,0		
PD23H150	23	1	97,0	92,98	91,61	-	72,0	-	46,0	58,0	12,0		
PD24H150	24	1	102,0	97,02	95,65	-	80,0	-	46,0	58,0	12,0		
PD25H150	25	1	106,0	101,06	99,69	-	80,0	-	46,0	58,0	12,0		
PD26H150	26	1	112,0	105,11	103,74	-	85,0	-	46,0	58,0	12,0		
PD27H150	27	1	115,0	109,15	107,78	-	88,0	-	46,0	58,0	12,0		
PD28H150	28	1	120,0	113,19	111,92	-	94,0	-	46,0	58,0	12,0		
PD29H150	29	1	120,0	117,23	115,86	-	96,0	-	46,0	58,0	12,0		
PD30H150	30	1	128,0	121,28	119,91	-	104,0	-	46,0	58,0	12,0		
PD32H150	32	1	135,0	129,36	127,99	-	112,0	-	46,0	58,0	12,0		
PD33H150	33	1	142,0	133,40	132,03	-	112,0	-	46,0	58,0	12,0		
PD34H150	34	1	142,0	137,45	136,08	-	118,0	-	46,0	58,0	12,0		
PD35H150	35	3	150,0	141,49	140,12	118,0	75,0	12,0	46,0	58,0	12,0		
PD36H150	36	3	150,0	145,53	144,16	118,0	75,0	12,0	46,0	58,0	12,0		
PD38H150	38	3	158,0	153,62	152,25	126,0	75,0	12,0	46,0	58,0	12,0		
PD40H150	40	3	168,0	161,70	160,33	134,0	75,0	12,0	46,0	70,0	24,0		
PD44H150	44	3	184,0	177,87	176,50	150,0	75,0	18,0	46,0	70,0	24,0		
PD45H150	45	3	192,0	181,91	180,54	154,0	75,0	18,0	46,0	70,0	24,0		
PD48H150	48	3	200,0	194,04	192,67	166,0	75,0	18,0	46,0	70,0	24,0		
PD49H150	49	3A	-	198,08	196,71	170,0	75,0	18,0	46,0	70,0	24,0		
PD50H150	50	3A	-	202,13	200,76	174,0	75,0	18,0	46,0	70,0	24,0		
PD52H150	52	3A	-	210,21	208,84	182,0	75,0	18,0	46,0	70,0	24,0		
PD60H150	60	3A	-	242,55	241,18	215,0	80,0	18,0	46,0	70,0	24,0		
PD70H150	70	3A	-	282,98	281,61	255,0	80,0	24,0	46,0	70,0	24,0		
PD72H150	72	3A	-	291,06	289,69	263,0	80,0	24,0	46,0	70,0	24,0		
PD82H150	82	5A	-	331,49	330,12	304,0	80,0	24,0	46,0	70,0	24,0		
PD84H150	84	5A	-	339,57	338,20	312,0	90,0	24,0	46,0	70,0	24,0		
PD94H150	94	5A	-	380,00	378,63	352,0	90,0	24,0	46,0	70,0	24,0		
PD96H150	96	5A	-	388,08	386,71	360,0	100,0	24,0	46,0	70,0	24,0		
PD106H150	106	5A	-	428,51	427,14	401,0	100,0	24,0	46,0	70,0	24,0		
PD116H150	116	5A	-	468,93	467,56	441,0	100,0	24,0	46,0	70,0	24,0		
PD118H150	118	5A	-	477,02	475,65	449,0	100,0	24,0	46,0	70,0	24,0		
PD120H150	120	5A	-	485,10	483,73	458,0	100,0	24,0	46,0	70,0	24,0		
PD150H150	150	5A	-	606,38	605,01	579,0	100,0	24,0	46,0	70,0	24,0		
PD152H150	152	5A	-	614,46	613,09	587,0	100,0	24,0	46,0	70,0	24,0		
PD154H150	154	5A	-	622,55	621,17	595,0	100,0	24,0	46,0	70,0	24,0		
PD156H150	156	5A	-	630,63	629,26	603,0	120,0	24,0	46,0	70,0	24,0		

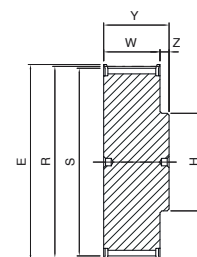

1

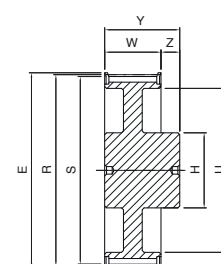

3*

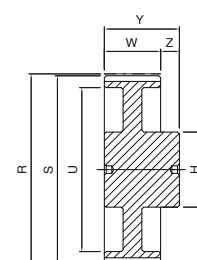

3A*

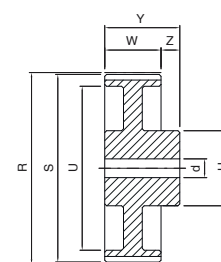

5A

* = Un pré-alésage, de diamètre maximal «d», peut être présent.

Dimensions des poulies dentées, pas en pouces - moyeu plein



PD ... H 200

H

Code	Nb de dents	Type	E [mm]	R [mm]	S [mm]	U [mm]	H [mm]	d [mm]	W [mm]	Y [mm]	Z [mm]	Flasque	Matière
PD14H200	14	1	64,0	56,60	55,23	-	40,0	-	59,5	72,0	12,5	avec flasque	acier
PD15H200	15	1	66,5	60,64	59,27	-	45,0	-	59,5	72,0	12,5		
PD16H200	16	1	70,0	64,68	63,31	-	47,0	-	59,5	72,0	12,5		
PD17H200	17	1	75,0	68,72	67,35	-	49,0	-	59,5	72,0	12,5		
PD18H200	18	1	79,0	72,77	71,40	-	57,0	-	59,5	72,0	12,5		
PD19H200	19	1	82,5	76,81	75,44	-	60,0	-	59,5	72,0	12,5		
PD20H200	20	1	87,0	80,85	79,48	-	64,0	-	59,5	72,0	12,5		
PD21H200	21	1	91,0	84,89	83,52	-	64,0	-	59,5	72,0	12,5		
PD22H200	22	1	94,0	88,94	87,57	-	70,0	-	59,5	72,0	12,5		
PD23H200	23	1	97,0	92,98	91,61	-	72,0	-	59,5	72,0	12,5		
PD24H200	24	1	102,0	97,02	95,65	-	80,0	-	59,5	72,0	12,5		
PD25H200	25	1	106,0	101,06	99,69	-	80,0	-	59,5	72,0	12,5		
PD26H200	26	1	112,0	105,11	103,74	-	85,0	-	59,5	72,0	12,5		
PD27H200	27	1	115,0	109,15	107,78	-	88,0	-	59,5	72,0	12,5		
PD28H200	28	1	120,0	113,19	111,92	-	94,0	-	59,5	72,0	12,5		
PD29H200	29	1	120,0	117,23	115,86	-	96,0	-	59,5	72,0	12,5		
PD30H200	30	1	128,0	121,28	119,91	-	104,0	-	59,5	72,0	12,5		
PD32H200	32	1	135,0	129,36	127,99	-	112,0	-	59,5	72,0	12,5		
PD33H200	33	1	142,0	133,40	132,03	-	112,0	-	59,5	72,0	12,5		
PD34H200	34	1	142,0	137,45	136,08	-	118,0	-	59,5	72,0	12,5		
PD35H200	35	3	150,0	141,49	140,12	118,0	80,0	12,0	59,5	72,0	12,5		
PD36H200	36	3	150,0	145,53	144,16	118,0	80,0	12,0	59,5	72,0	12,5		
PD38H200	38	3	158,0	153,62	152,25	126,0	80,0	12,0	59,5	72,0	12,5		
PD40H200	40	3	168,0	161,70	160,33	134,0	80,0	12,0	59,5	72,0	12,5		
PD44H200	44	3	184,0	177,87	176,50	150,0	80,0	18,0	59,5	72,0	12,5		
PD45H200	45	3	192,0	181,91	180,54	154,0	80,0	18,0	59,5	72,0	12,5		
PD48H200	48	3	200,0	194,04	192,67	166,0	80,0	24,0	59,5	80,0	20,5		
PD49H200	49	3A	-	198,08	196,71	170,0	80,0	24,0	59,5	80,0	20,5		
PD50H200	50	3A	-	202,13	200,76	174,0	80,0	24,0	59,5	80,0	20,5		
PD52H200	52	3A	-	210,21	208,84	182,0	80,0	24,0	59,5	80,0	20,5		
PD60H200	60	3A	-	242,55	241,18	215,0	90,0	24,0	59,5	80,0	20,5		
PD70H200	70	3A	-	282,98	281,61	255,0	90,0	28,0	59,5	80,0	20,5		
PD72H200	72	3A	-	291,06	289,69	263,0	90,0	28,0	59,5	80,0	20,5		
PD82H200	82	5A	-	331,49	330,12	304,0	90,0	28,0	59,5	80,0	20,5		
PD84H200	84	5A	-	339,57	338,20	312,0	100,0	28,0	59,5	80,0	20,5		
PD94H200	94	5A	-	380,00	378,63	352,0	100,0	28,0	59,5	80,0	20,5		
PD96H200	96	5A	-	388,08	386,71	360,0	100,0	28,0	59,5	80,0	20,5		
PD106H200	106	5A	-	428,51	427,14	401,0	100,0	28,0	59,5	80,0	20,5		
PD116H200	116	5A	-	468,93	467,56	441,0	100,0	28,0	59,5	80,0	20,5		
PD118H200	118	5A	-	477,02	475,65	449,0	100,0	28,0	59,5	80,0	20,5		
PD120H200	120	5A	-	485,10	483,73	458,0	120,0	28,0	59,5	80,0	20,5		
PD150H200	150	5A	-	606,38	605,01	579,0	120,0	28,0	59,5	80,0	20,5		
PD152H200	152	5A	-	614,46	613,09	587,0	120,0	28,0	59,5	80,0	20,5		
PD154H200	154	5A	-	622,55	621,17	595,0	120,0	28,0	59,5	80,0	20,5		
PD156H200	156	5A	-	630,63	629,26	603,0	130,0	28,0	59,5	80,0	20,5		

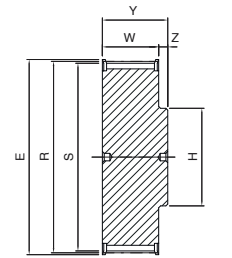

1

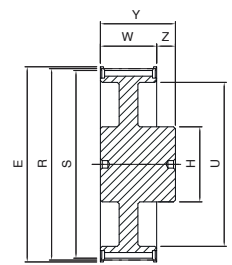

3*

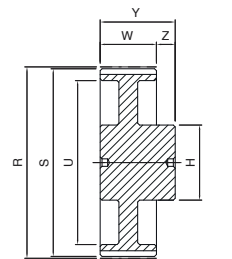

3A*

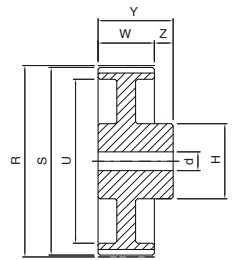

5A

* = Un pré-alésage, de diamètre maximal "d", peut être présent.

Dimensions des poulies dentées, pas en pouces - moyeu plein



PD ... H 300

H

Code	Nb de dents	Type	E [mm]	R [mm]	S [mm]	U [mm]	H [mm]	d [mm]	W [mm]	Y [mm]	Z [mm]	Flasque	Matière
PD14H300	14	1	64,0	56,60	55,23	-	40,0	-	85,7	98,0	12,3	avec flasque	acier
PD15H300	15	1	66,0	60,64	59,27	-	45,0	-	85,7	98,0	12,3		
PD16H300	16	1	70,0	64,68	63,31	-	47,0	-	85,7	98,0	12,3		
PD17H300	17	1	75,0	68,72	67,35	-	49,0	-	85,7	98,0	12,3		
PD18H300	18	1	79,0	72,77	71,40	-	57,0	-	85,7	98,0	12,3		
PD19H300	19	1	83,0	76,81	75,44	-	60,0	-	85,7	98,0	12,3		
PD20H300	20	1	87,0	80,85	79,48	-	64,0	-	85,7	98,0	12,3		
PD21H300	21	1	91,0	84,89	83,52	-	64,0	-	85,7	98,0	12,3		
PD22H300	22	1	93,0	88,94	87,57	-	70,0	-	85,7	98,0	12,3		
PD23H300	23	1	97,0	92,98	91,61	-	72,0	-	85,7	98,0	12,3		
PD24H300	24	1	102,0	97,02	95,65	-	80,0	-	85,7	98,0	12,3		
PD25H300	25	1	106,0	101,06	99,69	-	80,0	-	85,7	98,0	12,3		
PD26H300	26	1	112,0	105,11	103,74	-	85,0	-	85,7	98,0	12,3		
PD27H300	27	1	115,0	109,15	107,78	-	88,0	-	85,7	98,0	12,3		
PD28H300	28	1	120,0	113,19	111,92	-	94,0	-	85,7	98,0	12,3		
PD29H300	29	1	120,0	117,23	115,86	-	96,0	-	85,7	98,0	12,3		
PD30H300	30	1	128,0	121,28	119,91	-	104,0	-	85,7	98,0	12,3		
PD32H300	32	1	135,0	129,36	127,99	-	112,0	-	85,7	98,0	12,3		
PD33H300	33	1	142,0	133,40	132,03	-	112,0	-	85,7	98,0	12,3		
PD34H300	34	1	142,0	137,45	136,08	-	118,0	-	85,7	98,0	12,3		
PD35H300	35	3	150,0	141,49	140,12	118,0	75,0	18,0	85,7	98,0	12,3		
PD36H300	36	3	150,0	145,53	144,16	118,0	80,0	18,0	85,7	98,0	12,3		
PD38H300	38	3	158,0	153,62	152,25	126,0	80,0	18,0	85,7	98,0	12,3		
PD40H300	40	3	168,0	161,70	160,33	134,0	80,0	18,0	85,7	98,0	12,3		
PD44H300	44	3	184,0	177,87	176,50	150,0	80,0	24,0	85,7	98,0	12,3		
PD45H300	45	3	192,0	181,91	180,54	154,0	80,0	24,0	85,7	98,0	12,3		
PD48H300	48	3	200,0	194,04	192,67	166,0	90,0	24,0	85,7	98,0	12,3		
PD49H300	49	3A	-	198,08	196,71	170,0	90,0	24,0	85,7	98,0	12,3		
PD50H300	50	3A	-	202,13	200,76	174,0	90,0	24,0	85,7	98,0	12,3		
PD52H300	52	3A	-	210,21	208,84	182,0	90,0	24,0	85,7	98,0	12,3		
PD60H300	60	3A	-	242,55	241,18	215,0	100,0	24,0	85,7	98,0	12,3		
PD70H300	70	3A	-	282,98	281,61	255,0	100,0	28,0	85,7	98,0	12,3		
PD72H300	72	3A	-	291,06	289,69	263,0	100,0	28,0	85,7	98,0	12,3		
PD82H300	82	5A	-	331,49	330,12	304,0	100,0	28,0	85,7	98,0	12,3		
PD84H300	84	5A	-	339,57	338,20	312,0	100,0	28,0	85,7	98,0	12,3		
PD94H300	94	5A	-	380,00	378,63	352,0	100,0	28,0	85,7	98,0	12,3		
PD96H300	96	5A	-	388,08	386,71	360,0	110,0	28,0	85,7	98,0	12,3		
PD106H300	106	5A	-	428,51	427,14	401,0	110,0	28,0	85,7	98,0	12,3		
PD116H300	116	5A	-	468,93	467,56	441,0	110,0	28,0	85,7	98,0	12,3		
PD118H300	118	5A	-	477,02	475,65	449,0	110,0	28,0	85,7	98,0	12,3		
PD120H300	120	5A	-	485,10	483,73	458,0	120,0	28,0	85,7	98,0	12,3		
PD150H300	150	5A	-	606,38	605,01	579,0	120,0	28,0	85,7	98,0	12,3		
PD152H300	152	5A	-	614,46	613,09	587,0	120,0	28,0	85,7	98,0	12,3		
PD154H300	154	5A	-	622,55	621,17	595,0	120,0	28,0	85,7	98,0	12,3		
PD156H300	156	5A	-	630,63	629,26	603,0	130,0	28,0	85,7	98,0	12,3		

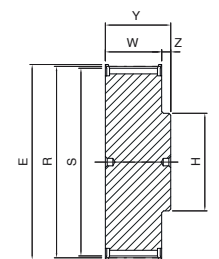

1

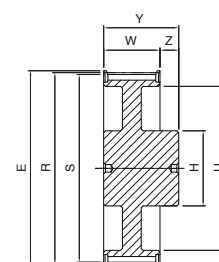

3*

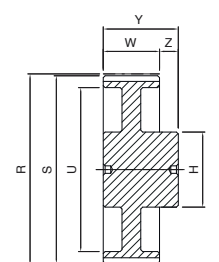

3A*

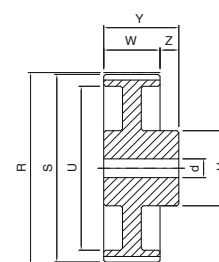

5A

* = Un pré-alésage, de diamètre maximal «d», peut être présent.

Dimensions des poulies dentées, pas en pouces - moyeu plein



PD ... XH 200

XH

Code	Nb de dents	Type	E [mm]	R [mm]	S [mm]	U [mm]	H [mm]	d [mm]	W [mm]	Y [mm]	Z [mm]	Flasque	Matière
PD18XH200	18	1	134,0	127,34	124,55	-	100,0	-	65,0	80,0	15,0	avec flasque	fonte
PD19XH200	19	1	142,0	134,41	131,62	-	107,0	-	65,0	80,0	15,0		
PD20XH200	20	1	150,0	141,49	138,70	-	114,0	-	65,0	80,0	15,0		
PD21XH200	21	1	158,0	148,56	145,77	-	122,0	-	65,0	80,0	15,0		
PD22XH200	22	1	166,0	155,64	152,85	-	128,0	-	65,0	80,0	15,0		
PD24XH200	24	1	177,0	169,79	167,00	-	141,0	-	65,0	80,0	15,0		
PD25XH200	25	3	186,0	176,86	174,07	-	90,0	-	65,0	80,0	15,0		
PD26XH200	26	3	191,0	183,94	181,15	-	90,0	-	65,0	80,0	15,0		
PD27XH200	27	1	200,0	191,01	188,22	-	158,0	-	65,0	80,0	15,0		
PD28XH200	28	1	209,0	198,08	195,29	-	169,0	-	65,0	80,0	15,0		
PD30XH200	30	3	216,0	212,23	209,44	170,0	100,0	-	65,0	80,0	15,0		
PD32XH200	32	3	232,0	226,38	223,59	184,0	110,0	-	65,0	80,0	15,0		
PD34XH200	34	3	261,0	240,53	237,74	198,0	110,0	-	65,0	80,0	15,0		
PD38XH200	38	3	274,0	268,83	266,03	227,0	110,0	-	65,0	80,0	15,0		
PD40XH200	40	3	288,0	282,98	280,19	241,0	120,0	-	65,0	100,0	35,0		
PD46XH200	46	5B	-	325,42	322,63	283,0	120,0	19,0	65,0	100,0	35,0		
PD48XH200	48	5A	-	339,57	336,78	297,0	120,0	19,0	65,0	100,0	35,0		
PD58XH200	58	5A	-	410,32	407,52	368,0	120,0	19,0	65,0	100,0	35,0		
PD60XH200	60	5A	-	424,47	421,68	382,0	130,0	19,0	65,0	100,0	35,0		
PD70XH200	70	5B	-	495,21	492,42	453,0	130,0	19,0	65,0	100,0	35,0		
PD72XH200	72	5B	-	509,36	506,57	467,0	140,0	19,0	65,0	100,0	35,0		
PD78XH200	78	5B	-	551,80	549,01	510,0	140,0	19,0	65,0	100,0	35,0		
PD80XH200	80	5B	-	565,95	563,16	524,0	140,0	19,0	65,0	100,0	35,0		
PD82XH200	82	5B	-	580,10	577,31	538,0	140,0	19,0	65,0	100,0	35,0		
PD84XH200	84	5B	-	594,25	591,46	552,0	150,0	19,0	65,0	100,0	35,0		
PD94XH200	94	5B	-	664,99	662,20	623,0	150,0	19,0	65,0	100,0	35,0		
PD96XH200	96	5B	-	679,14	676,35	637,0	160,0	19,0	65,0	100,0	35,0		
PD118XH200	118	5B	-	834,78	831,99	792,0	160,0	19,0	65,0	100,0	35,0		
PD120XH200	120	5B	-	848,93	846,14	806,0	170,0	19,0	65,0	100,0	35,0		

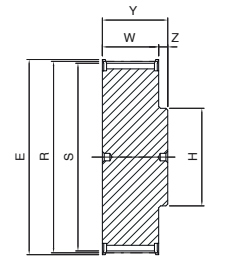

1

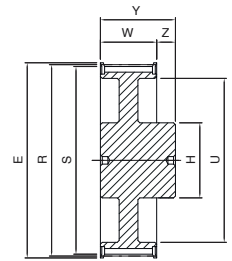

3

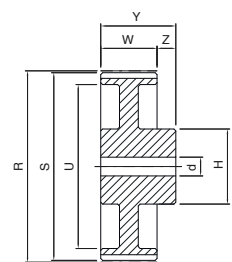

5A

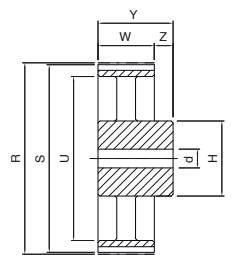

5B

Dimensions des poulies dentées, pas en pouces - moyeu plein



PD ... XH 300

XH

Code	Nb de dents	Type	E [mm]	R [mm]	S [mm]	U [mm]	H [mm]	d [mm]	W [mm]	Y [mm]	Z [mm]	Flasque	Matière
PD18XH300	18	1	134,0	127,34	124,55	-	100,0	-	92,0	107,0	15,0	avec flasque	fonte
PD19XH300	19	1	142,0	134,41	131,62	-	107,0	-	92,0	107,0	15,0		
PD20XH300	20	1	150,0	141,49	138,70	-	114,0	-	92,0	107,0	15,0		
PD21XH300	21	1	158,0	148,56	145,77	-	122,0	-	92,0	107,0	15,0		
PD22XH300	22	1	166,0	155,64	152,85	-	128,0	-	92,0	107,0	15,0		
PD24XH300	24	1	177,0	169,79	167,00	-	141,0	-	92,0	107,0	15,0		
PD25XH300	25	1	186,0	176,86	174,07	-	148,0	-	92,0	107,0	15,0		
PD26XH300	26	1	191,0	183,94	181,15	-	157,0	-	92,0	107,0	15,0		
PD27XH300	27	1	200,0	191,01	188,22	-	158,0	-	92,0	107,0	15,0		
PD28XH300	28	1	209,0	198,08	195,29	-	169,0	-	92,0	107,0	15,0		
PD30XH300	30	3	216,0	212,23	209,44	170,0	110,0	-	92,0	107,0	15,0		
PD32XH300	32	3	232,0	226,38	223,59	184,0	110,0	-	92,0	107,0	15,0		
PD34XH300	34	3	261,0	240,53	237,74	198,0	110,0	-	92,0	107,0	15,0		
PD38XH300	38	3	274,0	268,83	266,03	227,0	110,0	-	92,0	107,0	15,0		
PD40XH300	40	3	288,0	282,98	280,19	241,0	120,0	-	92,0	100,0	8,0		
PD46XH300	46	5A	-	325,42	322,63	283,0	120,0	19,0	92,0	100,0	8,0		
PD48XH300	48	5A	-	339,57	336,78	297,0	120,0	19,0	92,0	100,0	8,0		
PD58XH300	58	5A	-	410,32	407,52	368,0	120,0	19,0	92,0	100,0	8,0		
PD60XH300	60	5A	-	424,47	421,68	382,0	120,0	19,0	92,0	100,0	8,0		
PD70XH300	70	5B	-	495,21	492,42	453,0	130,0	19,0	92,0	100,0	8,0		
PD72XH300	72	5B	-	509,36	506,57	467,0	140,0	19,0	92,0	120,0	28,0		
PD78XH300	78	5B	-	551,80	549,01	510,0	140,0	19,0	92,0	120,0	28,0		
PD80XH300	80	5B	-	565,95	563,16	524,0	140,0	19,0	92,0	120,0	28,0		
PD82XH300	82	5B	-	580,10	577,31	538,0	140,0	19,0	92,0	120,0	28,0		
PD84XH300	84	5B	-	594,25	591,46	552,0	160,0	19,0	92,0	120,0	28,0		
PD94XH300	94	5B	-	664,99	662,20	623,0	150,0	19,0	92,0	120,0	28,0		
PD96XH300	96	5B	-	679,14	676,35	637,0	160,0	19,0	92,0	120,0	28,0		
PD118XH300	118	5B	-	834,78	831,99	792,0	160,0	19,0	92,0	120,0	28,0		
PD120XH300	120	5B	-	848,93	846,14	806,0	170,0	19,0	92,0	120,0	28,0		

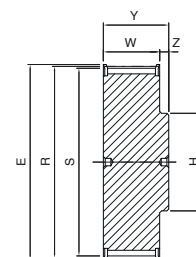

1

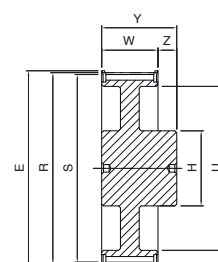

3

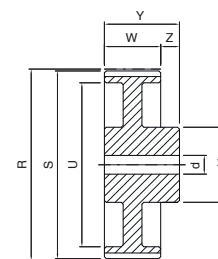

5A

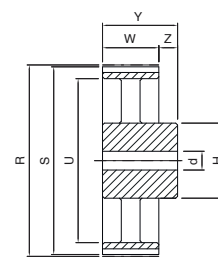

5B

Dimensions des poulies dentées, pas en pouces - moyeu plein



PD ... XH400

XH

Code	Nb de dents	Type	E [mm]	R [mm]	S [mm]	U [mm]	H [mm]	d [mm]	W [mm]	Y [mm]	Z [mm]	Flasque	Matière
PD18XH400	18	1	134,0	127,34	124,55	-	100,0	-	119,0	135,0	16,0	avec flasque	fonte
PD19XH400	19	1	142,0	134,41	131,62	-	107,0	-	119,0	135,0	16,0		
PD20XH400	20	1	150,0	141,49	138,70	-	114,0	-	119,0	135,0	16,0		
PD21XH400	21	1	158,0	148,56	145,77	-	122,0	-	119,0	135,0	16,0		
PD22XH400	22	1	166,0	155,64	152,85	-	128,0	-	119,0	135,0	16,0		
PD24XH400	24	1	177,0	169,79	167,00	-	141,0	-	119,0	135,0	16,0		
PD25XH400	25	1	186,0	176,86	174,07	-	148,0	-	119,0	135,0	16,0		
PD26XH400	26	1	191,0	183,94	181,15	-	157,0	-	119,0	135,0	16,0		
PD27XH400	27	1	200,0	191,01	188,22	-	158,0	-	119,0	135,0	16,0		
PD28XH400	28	1	209,0	198,08	195,29	-	169,0	-	119,0	135,0	16,0		
PD30XH400	30	3	216,0	212,23	209,44	170,0	120,0	-	119,0	135,0	16,0		
PD32XH400	32	3	232,0	226,38	223,59	184,0	120,0	-	119,0	135,0	16,0		
PD34XH400	34	3	261,0	240,53	237,74	198,0	120,0	-	119,0	135,0	16,0		
PD38XH400	38	3	274,0	268,83	266,03	227,0	120,0	-	119,0	135,0	16,0		
PD40XH400	40	3	288,0	282,98	280,19	241,0	120,0	-	119,0	135,0	16,0		
PD46XH400	46	3A	-	325,42	322,63	283,0	140,0	-	119,0	135,0	16,0		
PD48XH400	48	5A	-	339,57	336,78	297,0	140,0	19,0	119,0	135,0	16,0		
PD58XH400	58	5A	-	410,32	407,52	368,0	140,0	19,0	119,0	135,0	16,0		
PD60XH400	60	5A	-	424,47	421,68	382,0	140,0	19,0	119,0	135,0	16,0		
PD70XH400	70	5B	-	495,21	492,42	453,0	140,0	19,0	119,0	135,0	16,0		
PD72XH400	72	5B	-	509,36	506,57	467,0	140,0	19,0	119,0	135,0	16,0		
PD78XH400	78	5B	-	551,80	549,01	510,0	140,0	19,0	119,0	135,0	16,0		
PD80XH400	80	5B	-	565,95	563,16	524,0	140,0	19,0	119,0	135,0	16,0		
PD82XH400	82	5B	-	580,10	577,31	538,0	140,0	19,0	119,0	135,0	16,0		
PD84XH400	84	5B	-	594,25	591,46	552,0	160,0	19,0	119,0	135,0	16,0		
PD94XH400	94	5B	-	664,99	662,20	623,0	150,0	19,0	119,0	135,0	16,0		
PD96XH400	96	5B	-	679,14	676,35	637,0	160,0	19,0	119,0	135,0	16,0		
PD118XH400	118	5B	-	834,78	831,99	792,0	160,0	19,0	119,0	135,0	16,0		
PD120XH400	120	5B	-	848,93	846,14	806,0	170,0	19,0	119,0	135,0	16,0		

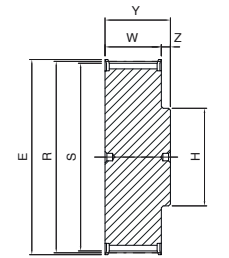

1

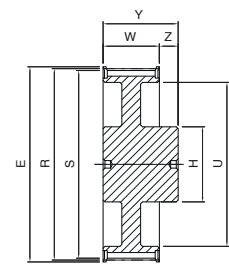

3

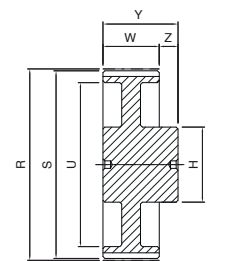

3A

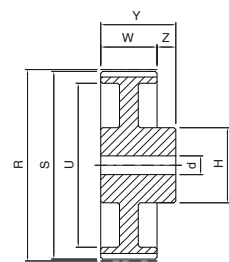

5A

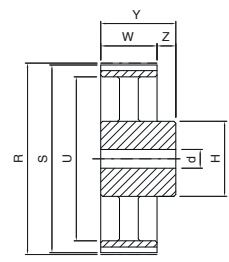

5B

Dimensions des poulies dentées, pas en pouces

- moyeu amovible SER-SIT®

Types L - H - XH



Désignation	PBD 40 L 050
Poulies dentées, pas en pouces - moyeu amovible	
Nombre de dents	
Pas	
Largeur de la courroie en pouces x 100	

PBD ... L050

Code	Nb de dents	Type	Moyeu amovible SER-SIT®	E [mm]	R [mm]	S [mm]	U [mm]	H [mm]	W [mm]	Y [mm]	Z [mm]	Flasque	Matière
PBD18L050	18	2	1108	60,0	54,57	53,81	-	47,0	19,0	22,0	3,0	avec flasque	fonte
PBD19L050	19	2	1108	64,0	57,61	56,84	-	47,0	19,0	22,0	3,0		
PBD20L050	20	2	1108	66,5	60,64	59,88	-	48,0	19,0	22,0	3,0		
PBD21L050	21	2	1108	70,0	63,67	62,91	-	48,0	19,0	22,0	3,0		
PBD22L050	22	2	1108	75,0	68,70	65,94	-	51,0	19,0	22,0	3,0		
PBD23L050	23	2	1108	79,0	69,73	68,97	-	51,0	19,0	22,0	3,0		
PBD24L050	24	2	1108	79,0	72,77	72,01	-	58,0	19,0	22,0	3,0		
PBD25L050	25	2	1108	82,5	75,80	75,04	-	58,0	19,0	22,0	3,0		
PBD26L050	26	2	1108	86,0	78,83	78,07	-	58,0	19,0	22,0	3,0		
PBD27L050	27	2	1108	86,0	81,86	81,10	-	58,0	19,0	22,0	3,0		
PBD28L050	28	2	1108	91,0	84,89	84,13	-	58,0	19,0	22,0	3,0		
PBD29L050	29	2	1108	94,0	87,93	87,16	-	58,0	19,0	22,0	3,0		
PBD30L050	30	2	1108	97,0	90,96	90,20	-	58,0	19,0	22,0	3,0		
PBD32L050	32	2	1108	102,0	97,02	96,26	-	58,0	19,0	22,0	3,0		
PBD33L050	33	2	1108	106,0	100,05	99,29	-	58,0	19,0	22,0	3,0		
PBD34L050	34	2	1108	112,0	103,08	103,32	-	58,0	19,0	22,0	3,0		
PBD35L050	35	9	1108	112,0	106,12	105,35	84,0	58,0	19,0	22,0	3,0		
PBD36L050	36	9	1108	115,0	109,15	108,39	84,0	58,0	19,0	22,0	3,0		
PBD40L050	40	2	1610	128,0	121,28	120,52	-	90,0	19,0	25,0	6,0		
PBD41L050	41	2	1610	128,0	124,31	123,55	-	90,0	19,0	25,0	6,0		
PBD42L050	42	9	1610	142,0	127,34	126,58	110,0	90,0	19,0	25,0	6,0		
PBD44L050	44	9	1610	142,0	133,40	132,64	110,0	90,0	19,0	25,0	6,0		
PBD45L050	45	9	1610	142,0	136,44	135,67	118,0	90,0	19,0	25,0	6,0		
PBD47L050	47	9	1610	150,0	142,50	141,74	126,0	90,0	19,0	25,0	6,0		
PBD48L050	48	9	1610	150,0	145,53	144,77	126,0	90,0	19,0	25,0	6,0		
PBD49L050	49	9A	1610	-	148,56	147,80	132,0	90,0	19,0	25,0	6,0		
PBD50L050	50	9A	1610	-	151,60	150,83	132,0	90,0	19,0	25,0	6,0		
PBD52L050	52	9A	1610	-	157,66	156,90	138,0	90,0	19,0	25,0	6,0		
PBD56L050	56	9A	1610	-	169,79	169,02	152,0	90,0	19,0	25,0	6,0		
PBD57L050	57	9A	1610	-	172,82	172,06	152,0	90,0	19,0	25,0	6,0		
PBD60L050	60	11A	1610	-	181,91	181,15	162,0	90,0	19,0	25,0	3,0		
PBD65L050	65	11B	1610	-	197,07	196,31	178,0	90,0	19,0	25,0	3,0		
PBD66L050	66	11B	1610	-	200,11	199,34	178,0	90,0	19,0	25,0	3,0		
PBD72L050	72	11B	1610	-	218,30	217,54	199,0	90,0	19,0	25,0	3,0		
PBD84L050	84	11B	1610	-	254,68	253,92	235,0	90,0	19,0	25,0	3,0		
PBD90L050	90	11B	1610	-	272,87	272,11	253,0	90,0	19,0	25,0	3,0		
PBD96L050	96	11B	2012	-	291,06	290,30	270,0	110,0	19,0	32,0	6,5		
PBD120L050	120	11B	2012	-	363,07	344,00	344,0	110,0	19,0	32,0	6,5		

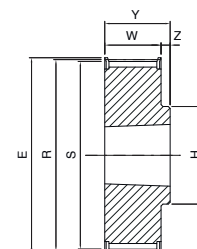

2

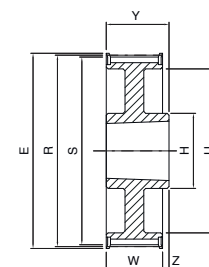

9

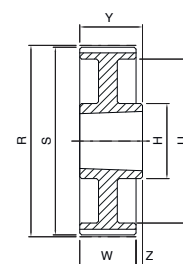

9A

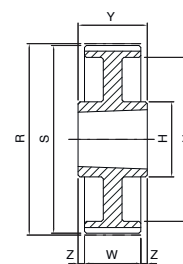

11A

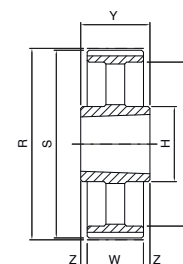

11B

Dimensions des poulies dentées, pas en pouces - moyeu amovible SER-SIT®



PBD ... L075

Code	Nb de dents	Type	Moyeu amovible SER-SIT®	E [mm]	R [mm]	S [mm]	U [mm]	H [mm]	W [mm]	Y [mm]	Z [mm]	Flasque	Matière
PBD18L075	18	4	1108	60,0	54,57	53,81	38,0	-	25,0	22,0	3,0	avec flasque	fonte
PBD19L075	19	4	1108	64,0	57,61	56,84	38,0	-	25,0	22,0	3,0		
PBD20L075	20	4	1108	66,5	60,64	59,88	46,0	-	25,0	22,0	3,0		
PBD21L075	21	4	1108	70,0	63,67	62,91	46,0	-	25,0	22,0	3,0		
PBD22L075	22	4	1108	75,0	68,70	65,94	46,0	-	25,0	22,0	3,0		
PBD23L075	23	4	1108	79,0	69,73	68,97	46,0	-	25,0	22,0	3,0		
PBD24L075	24	4	1108	79,0	72,77	72,01	53,0	-	25,0	22,0	3,0		
PBD25L075	25	4	1108	82,5	75,80	75,04	53,0	-	25,0	22,0	3,0		
PBD26L075	26	4	1108	86,0	78,83	78,07	60,0	-	25,0	22,0	3,0		
PBD27L075	27	4	1108	86,0	81,86	81,10	60,0	-	25,0	22,0	3,0		
PBD28L075	28	4	1108	91,0	84,89	84,13	65,0	-	25,0	22,0	3,0		
PBD29L075	29	4	1108	94,0	87,93	87,16	65,0	-	25,0	22,0	3,0		
PBD30L075	30	4	1108	97,0	90,96	90,20	68,0	-	25,0	22,0	3,0		
PBD32L075	32	4	1108	102,0	97,02	96,26	76,0	-	25,0	22,0	3,0		
PBD33L075	33	4	1108	106,0	100,05	99,29	83,0	-	25,0	22,0	3,0		
PBD34L075	34	4	1108	112,0	103,08	102,32	85,0	-	25,0	22,0	3,0		
PBD35L075	35	6	1610	112,0	106,12	105,35	-	-	25,0	25,0	-		
PBD36L075	36	6	1610	115,0	109,15	108,39	-	-	25,0	25,0	-		
PBD40L075	40	6	1610	128,0	121,28	120,52	-	-	25,0	25,0	-		
PBD41L075	41	6	1610	128,0	124,31	123,55	-	-	25,0	25,0	-		
PBD42L075	42	7	1610	142,0	127,34	126,58	110,0	90,0	25,0	25,0	-		
PBD44L075	44	7	1610	142,0	133,40	132,64	110,0	90,0	25,0	25,0	-		
PBD45L075	45	7	1610	142,0	136,44	135,67	118,0	90,0	25,0	25,0	-		
PBD47L075	47	7	1610	150,0	142,50	141,74	126,0	90,0	25,0	25,0	-		
PBD48L075	48	7	1610	150,0	145,53	144,77	126,0	90,0	25,0	25,0	-		
PBD49L075	49	7A	1610	-	148,56	147,80	132,0	90,0	25,0	25,0	-		
PBD50L075	50	7A	1610	-	151,60	150,83	132,0	90,0	25,0	25,0	-		
PBD52L075	52	7A	1610	-	157,66	156,90	138,0	90,0	25,0	25,0	-		
PBD56L075	56	7A	1610	-	169,79	169,02	152,0	90,0	25,0	25,0	-		
PBD57L075	57	7A	1610	-	172,82	172,06	152,0	90,0	25,0	25,0	-		
PBD60L075	60	7A	1610	-	181,91	181,15	162,0	90,0	25,0	25,0	-		
PBD65L075	65	7A	1610	-	197,07	196,31	178,0	90,0	25,0	25,0	-		
PBD66L075	66	7A	1610	-	200,11	199,34	178,0	90,0	25,0	25,0	-		
PBD72L075	72	7B	1610	-	218,30	217,54	199,0	90,0	25,0	25,0	-		
PBD84L075	84	11B	2012	-	254,68	253,92	235,0	110,0	25,0	32,0	3,5		
PBD90L075	90	11B	2012	-	272,87	272,11	253,0	110,0	25,0	32,0	3,5		
PBD96L075	96	11B	2012	-	291,06	290,30	270,0	110,0	25,0	32,0	3,5		
PBD120L075	120	11B	2012	-	363,83	363,07	344,0	110,0	25,0	32,0	3,5		

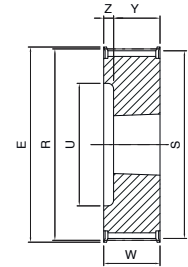

4

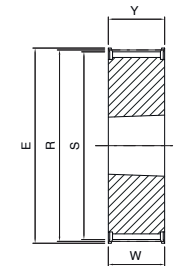

6

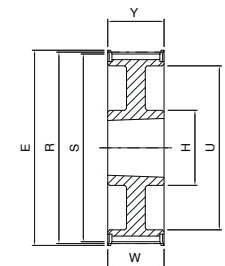

7

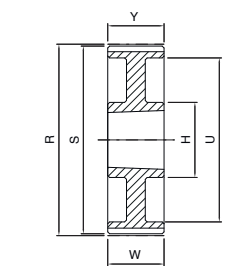

7A

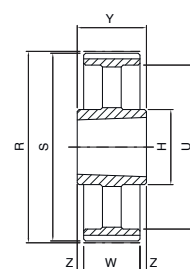

11B

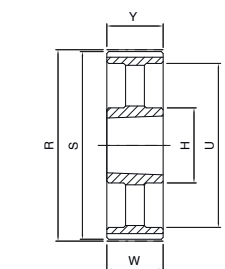

7B

Dimensions des poulies dentées, pas en pouces - moyeu amovible SER-SIT®



PBD ... L100

L

Code	Nb de dents	Type	Moyeu amovible SER-SIT®	E [mm]	R [mm]	S [mm]	U [mm]	H [mm]	W [mm]	Y [mm]	Z [mm]	Flasque	Matière
PBD18L100	18	4	1108	60,0	54,57	53,81	38,0	-	32,0	22,0	10,0	avec flasque	fonte
PBD19L100	19	4	1108	64,0	57,61	56,84	38,0	-	32,0	22,0	10,0		
PBD20L100	20	4	1108	66,5	60,64	59,88	46,0	-	32,0	22,0	10,0		
PBD21L100	21	4	1108	70,0	63,67	62,91	46,0	-	32,0	22,0	10,0		
PBD22L100	22	4	1108	75,0	68,70	65,94	46,0	-	32,0	22,0	10,0		
PBD23L100	23	4	1108	79,0	69,73	68,97	46,0	-	32,0	22,0	10,0		
PBD24L100	24	4	1108	79,0	72,77	72,01	53,0	-	32,0	22,0	10,0		
PBD25L100	25	4	1108	82,5	75,80	75,04	53,0	-	32,0	22,0	10,0		
PBD26L100	26	4	1108	86,0	78,83	78,07	60,0	-	32,0	22,0	10,0		
PBD27L100	27	4	1108	86,0	81,86	81,10	60,0	-	32,0	22,0	10,0		
PBD28L100	28	4	1108	91,0	84,89	84,13	65,0	-	32,0	22,0	10,0		
PBD29L100	29	4	1210	94,0	87,93	87,16	68,0	-	32,0	25,0	7,0		
PBD30L100	30	4	1210	97,0	90,96	90,20	68,0	-	32,0	25,0	7,0		
PBD32L100	32	4	1210	102,0	97,02	96,26	76,0	-	32,0	25,0	7,0		
PBD33L100	33	4	1610	106,0	100,05	99,29	83,0	-	32,0	25,0	7,0		
PBD34L100	34	4	1610	112,0	103,08	102,32	85,0	-	32,0	25,0	7,0		
PBD35L100	35	4	1610	112,0	106,12	105,35	85,0	-	32,0	25,0	7,0		
PBD36L100	36	4	1610	115,0	109,15	108,39	85,0	-	32,0	25,0	7,0		
PBD40L100	40	4	1610	128,0	121,28	120,52	100,0	-	32,0	25,0	7,0		
PBD41L100	41	4	1610	128,0	124,31	123,55	100,0	-	32,0	25,0	7,0		
PBD42L100	42	10	1610	142,0	127,34	126,58	110,0	90,0	32,0	25,0	7,0		
PBD44L100	44	10	1610	142,0	133,40	132,64	110,0	90,0	32,0	25,0	7,0		
PBD45L100	45	10	1610	142,0	136,44	135,67	118,0	90,0	32,0	25,0	7,0		
PBD47L100	47	10	1610	150,0	142,50	141,74	126,0	90,0	32,0	25,0	7,0		
PBD48L100	48	10	1610	150,0	145,53	144,77	126,0	90,0	32,0	25,0	7,0		
PBD49L100	49	10A	1610	-	148,56	147,80	132,0	90,0	32,0	25,0	7,0		
PBD50L100	50	10A	1610	-	151,60	150,83	132,0	90,0	32,0	25,0	7,0		
PBD52L100	52	10A	1610	-	157,66	156,90	138,0	90,0	32,0	25,0	7,0		
PBD56L100	56	10A	1610	-	169,79	169,02	152,0	90,0	32,0	25,0	7,0		
PBD57L100	57	10A	1610	-	172,82	172,06	152,0	90,0	32,0	25,0	7,0		
PBD60L100	60	8A	1610	-	181,91	181,15	162,0	90,0	32,0	25,0	3,5		
PBD65L100	65	8A	1610	-	197,07	196,31	178,0	90,0	32,0	25,0	3,5		
PBD66L100	66	8A	1610	-	200,11	199,34	178,0	90,0	32,0	25,0	3,5		
PBD72L100	72	7A	2012	-	218,30	217,54	199,0	110,0	32,0	32,0	-		
PBD84L100	84	7B	2012	-	254,68	253,92	235,0	110,0	32,0	32,0	-		
PBD90L100	90	7B	2012	-	272,87	272,11	253,0	110,0	32,0	32,0	-		
PBD96L100	96	7B	2012	-	291,06	290,30	270,0	110,0	32,0	32,0	-		
PBD120L100	120	7B	2012	-	363,83	363,07	344,0	110,0	32,0	32,0	-		

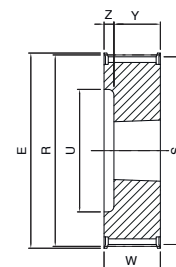

4

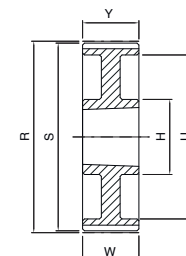

7A

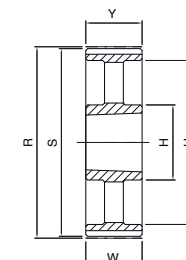

7B

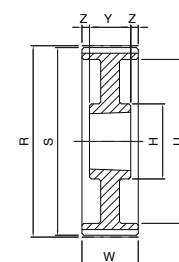

8A

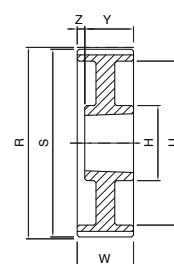

10A

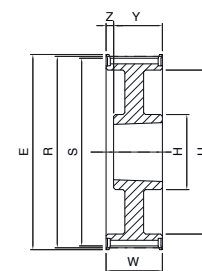

10

Dimensions des poulies dentées, pas en pouces - moyeu amovible SER-SIT®



PBD ... H100

H

Code	Nb de dents	Type	Moyeu amovible SER-SIT®	E [mm]	R [mm]	S [mm]	U [mm]	H [mm]	W [mm]	Y [mm]	Z [mm]	Flasque	Matière
PBD14H100	14	4	1108	64,0	56,60	55,23	37,0	-	31,0	22,0	9,0	avec flasque	fonte
PBD15H100	15	4	1108	66,5	60,64	59,27	37,0	-	31,0	22,0	9,0		
PBD16H100	16	4	1108	70,0	64,68	63,31	46,0	-	31,0	22,0	9,0		
PBD17H100	17	4	1210	75,0	68,72	67,35	46,0	-	31,0	25,0	6,0		
PBD18H100	18	4	1210	79,0	72,77	71,40	56,0	-	31,0	25,0	6,0		
PBD19H100	19	4	1210	82,5	76,81	75,44	56,0	-	31,0	25,0	6,0		
PBD20H100	20	4	1210	87,0	80,85	79,48	56,0	-	31,0	25,0	6,0		
PBD21H100	21	4	1210	91,0	84,89	83,52	62,0	-	32,0	25,0	7,0		
PBD22H100	22	4	1210	94,0	88,94	87,57	62,0	-	32,0	25,0	7,0		
PBD23H100	23	4	1610	97,0	92,98	91,61	71,0	-	32,0	25,0	7,0		
PBD24H100	24	4	1610	102,0	97,02	95,65	71,0	-	32,0	25,0	7,0		
PBD25H100	25	4	1610	106,0	101,06	99,69	78,0	-	32,0	25,0	7,0		
PBD26H100	26	4	1610	112,0	105,11	103,74	78,0	-	32,0	25,0	7,0		
PBD27H100	27	4	1610	115,0	109,15	107,78	86,0	-	32,0	25,0	7,0		
PBD28H100	28	4	1610	120,0	113,19	111,92	86,0	-	32,0	25,0	7,0		
PBD29H100	29	4	1610	120,0	117,23	115,86	95,0	-	32,0	25,0	7,0		
PBD30H100	30	4	1610	128,0	121,28	119,91	95,0	-	32,0	25,0	7,0		
PBD32H100	32	10	1610	135,0	129,36	127,99	110,0	82,0	32,0	25,0	7,0		
PBD33H100	33	7	1615	137,0	133,40	132,03	112,0	82,0	32,0	38,0	-		
PBD34H100	34	10	1610	142,0	137,45	136,08	112,0	82,0	32,0	25,0	7,0		
PBD35H100	35	10	1610	150,0	141,49	140,12	120,0	82,0	32,0	25,0	7,0		
PBD36H100	36	10	1610	150,0	145,53	144,16	120,0	82,0	32,0	25,0	7,0		
PBD38H100	38	10	1610	158,0	153,62	152,25	136,0	82,0	32,0	25,0	7,0		
PBD40H100	40	10	1610	168,0	161,70	160,33	136,0	82,0	32,0	25,0	7,0		
PBD44H100	44	7	2012	184,0	177,87	176,50	162,0	110,0	32,0	32,0	-		
PBD45H100	45	7	2012	192,0	181,91	180,54	162,0	110,0	32,0	32,0	-		
PBD48H100	48	7	2012	200,0	194,04	192,67	168,0	110,0	32,0	32,0	-		
PBD49H100	49	8A	2012	-	198,08	196,71	172,0	110,0	34,0	32,0	1,0		
PBD50H100	50	8A	2012	-	202,13	200,76	172,0	110,0	34,0	32,0	1,0		
PBD52H100	52	8A	2012	-	210,21	208,84	185,0	110,0	34,0	32,0	1,0		
PBD60H100	60	8A	2012	-	242,55	241,18	217,0	110,0	34,0	32,0	1,0		
PBD70H100	70	8B	2012	-	282,98	281,61	264,0	110,0	34,0	32,0	1,0		
PBD72H100	72	8B	2012	-	291,06	289,69	264,0	110,0	34,0	32,0	1,0		
PBD82H100	82	8B	2012	-	331,49	330,12	312,0	110,0	34,0	32,0	1,0		
PBD84H100	84	8B	2012	-	339,57	338,20	312,0	120,0	34,0	32,0	1,0		
PBD94H100	98	11B	2517	-	380,00	378,63	357,0	120,0	34,0	45,0	5,5		
PBD96H100	96	11B	2517	-	388,08	386,71	357,0	120,0	34,0	45,0	5,5		
PBD106H100	106	11B	2517	-	428,51	427,14	402,0	120,0	34,0	45,0	5,5		

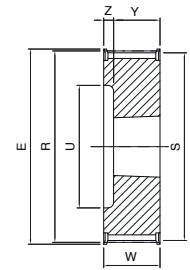

4

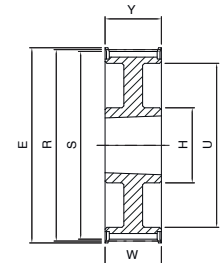

7

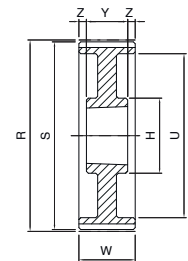

8A

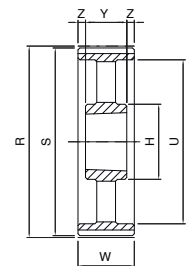

8B

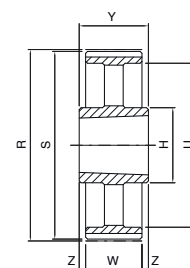

11B

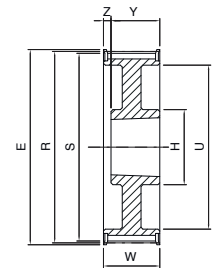

10

Dimensions des poulies dentées, pas en pouces - moyeu amovible SER-SIT®



PBD ... H150

H

Code	Nb de dents	Type	Moyeu amovible SER-SIT®	E [mm]	R [mm]	S [mm]	U [mm]	H [mm]	W [mm]	Y [mm]	Z [mm]	Flasque	Matière
PBD14H150	14	4	1108	64,0	56,60	55,23	37,0	-	45,0	22,0	23,0	avec flasque	fonte
PBD15H150	15	4	1108	66,5	60,64	59,27	37,0	-	45,0	22,0	23,0		
PBD16H150	16	4	1108	70,0	64,68	63,31	46,0	-	45,0	22,0	23,0		
PBD17H150	17	4	1210	75,0	68,72	67,35	46,0	-	45,0	25,0	20,0		
PBD18H150	18	4	1210	79,0	72,77	71,40	56,0	-	45,0	25,0	20,0		
PBD19H150	19	4	1210	82,5	76,81	75,44	56,0	-	45,0	25,0	20,0		
PBD20H150	20	4	1210	87,0	80,85	79,48	56,0	-	45,0	25,0	20,0		
PBD21H150	21	4	1210	91,0	84,89	83,52	67,0	-	45,0	25,0	20,0		
PBD22H150	22	4	1210	94,0	88,94	87,57	67,0	-	45,0	25,0	20,0		
PBD23H150	23	4	1610	97,0	92,98	91,61	71,0	-	45,0	25,0	20,0		
PBD24H150	24	4	1610	102,0	97,02	95,65	71,0	-	45,0	25,0	20,0		
PBD25H150	25	4	1610	106,0	101,06	99,69	78,0	-	45,0	25,0	20,0		
PBD26H150	26	4	1610	112,0	105,11	103,74	78,0	-	45,0	25,0	20,0		
PBD27H150	27	4	1610	115,0	109,15	107,78	86,0	-	45,0	25,0	20,0		
PBD28H150	28	4	1610	120,0	113,19	111,92	86,0	-	45,0	25,0	20,0		
PBD29H150	29	4	1610	120,0	117,23	115,86	95,0	-	45,0	25,0	20,0		
PBD30H150	30	4	1610	128,0	121,28	119,91	95,0	-	45,0	25,0	20,0		
PBD32H150	32	10	1610	135,0	129,36	127,99	110,0	82,0	45,0	25,0	20,0		
PBD33H150	33	10	1610	142,0	133,40	132,03	112,0	82,0	45,0	25,0	20,0		
PBD34H150	34	10	1610	142,0	137,45	136,08	112,0	82,0	45,0	25,0	20,0		
PBD35H150	35	10	1610	150,0	141,49	140,12	120,0	82,0	45,0	25,0	20,0		
PBD36H150	36	10	1610	150,0	145,53	144,16	120,0	82,0	45,0	25,0	20,0		
PBD38H150	38	10	1610	158,0	153,62	152,25	136,0	82,0	45,0	25,0	20,0		
PBD40H150	40	10	1610	168,0	161,70	160,33	136,0	82,0	45,0	25,0	20,0		
PBD44H150	44	10	2012	184,0	177,87	176,50	162,0	110,0	45,0	32,0	13,0		
PBD45H150	45	10	2012	192,0	181,91	180,54	162,0	110,0	45,0	32,0	13,0		
PBD48H150	48	10	2012	200,0	194,04	192,67	168,0	110,0	45,0	32,0	13,0		
PBD49H150	49	8A	2012	-	198,08	196,71	172,0	110,0	46,0	32,0	7,0		
PBD50H150	50	8A	2012	-	202,13	200,76	172,0	110,0	46,0	32,0	7,0		
PBD52H150	52	8A	2012	-	210,21	208,84	185,0	110,0	46,0	32,0	7,0		
PBD60H150	60	8B	2012	-	242,55	241,18	217,0	110,0	46,0	32,0	7,0		
PBD70H150	70	8B	2012	-	282,98	281,61	264,0	110,0	46,0	32,0	7,0		
PBD72H150	72	8B	2012	-	291,06	289,69	264,0	110,0	46,0	32,0	7,0		
PBD82H150	82	8B	2012	-	331,49	330,12	312,0	110,0	46,0	32,0	7,0		
PBD84H150	84	8B	2012	-	339,57	338,20	312,0	110,0	46,0	32,0	7,0		
PBD94H150	94	8B	2517	-	380,00	378,63	357,0	120,0	46,0	45,0	0,5		
PBD96H150	96	8B	2517	-	388,08	386,71	357,0	120,0	46,0	45,0	0,5		
PBD106H150	106	8B	2517	-	428,51	427,14	402,0	120,0	46,0	45,0	0,5		

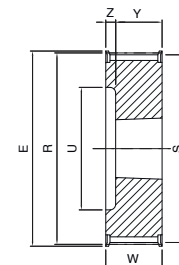

4

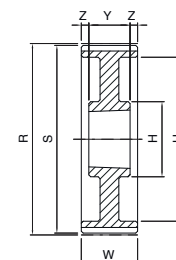

8A

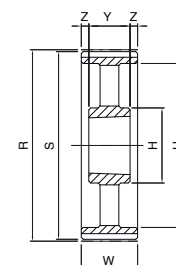

8B

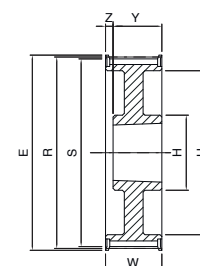

10

Dimensions des poulies dentées, pas en pouces - moyeu amovible SER-SIT®



PBD ... H200

H

Code	Nb de dents	Type	Moyeu amovible SER-SIT®	E [mm]	R [mm]	S [mm]	U [mm]	H [mm]	W [mm]	Y [mm]	Z [mm]	Flasque	Matière
PBD16H200	16	4	1108	70,0	64,68	63,31	46,0	-	58,0	22,0	36,0	avec flasque	fonte
PBD17H200	17	4	1210	75,0	68,72	67,35	52,0	-	58,0	25,0	33,0		
PBD18H200	18	4	1210	79,0	72,77	71,40	52,0	-	58,0	25,0	33,0		
PBD19H200	19	4	1610	82,5	76,81	75,44	56,0	-	58,0	25,0	33,0		
PBD20H200	20	4	1610	87,0	80,85	79,48	56,0	-	58,0	25,0	33,0		
PBD21H200	21	4	1610	91,0	84,89	83,52	67,0	-	58,0	25,0	33,0		
PBD22H200	22	4	1610	94,0	88,94	87,57	67,0	-	58,0	25,0	33,0		
PBD23H200	23	4	1610	97,0	92,98	91,61	71,0	-	58,0	25,0	33,0		
PBD24H200	24	4	1610	102,0	97,02	95,65	71,0	-	58,0	25,0	33,0		
PBD25H200	25	4	1610	106,0	101,06	99,69	78,0	-	58,0	25,0	33,0		
PBD26H200	26	4	1610	112,0	105,11	103,74	78,0	-	58,0	25,0	33,0		
PBD27H200	27	4	1610	115,0	109,15	107,78	86,0	-	58,0	25,0	33,0		
PBD28H200	28	4	1610	120,0	113,19	111,92	86,0	-	58,0	25,0	33,0		
PBD29H200	29	4	1610	120,0	117,23	115,86	95,0	-	58,0	25,0	33,0		
PBD30H200	30	4	1610	128,0	121,28	119,91	95,0	-	58,0	25,0	33,0		
PBD32H200	32	4	2012	135,0	129,36	127,99	106,0	-	58,0	32,0	26,0		
PBD33H200	33	4	2012	142,0	133,40	132,03	112,0	-	58,0	32,0	26,0		
PBD34H200	34	4	2012	142,0	137,45	136,08	112,0	-	58,0	32,0	26,0		
PBD35H200	35	10	2012	150,0	141,49	140,12	120,0	102,0	58,0	32,0	26,0		
PBD36H200	36	10	2012	150,0	145,53	144,16	120,0	102,0	58,0	32,0	26,0		
PBD38H200	38	10	2012	158,0	153,62	152,25	136,0	110,0	58,0	32,0	26,0		
PBD40H200	40	10	2012	168,0	161,70	160,33	136,0	110,0	58,0	32,0	26,0		
PBD44H200	44	10	2012	184,0	177,87	176,50	162,0	110,0	58,0	32,0	26,0		
PBD45H200	45	10	2012	192,0	181,91	180,54	162,0	110,0	58,0	32,0	26,0		
PBD48H200	48	10	2517	200,0	194,04	192,67	168,0	120,0	58,0	45,0	13,0		
PBD49H200	49	8A	2517	-	198,08	196,71	172,0	120,0	60,0	45,0	7,5		
PBD50H200	50	8A	2517	-	202,13	200,76	172,0	120,0	60,0	45,0	7,5		
PBD52H200	52	8A	2517	-	210,21	208,84	185,0	120,0	60,0	45,0	7,5		
PBD60H200	60	8B	2517	-	242,55	241,18	217,0	120,0	60,0	45,0	7,5		
PBD70H200	70	8B	2517	-	282,98	281,61	264,0	120,0	60,0	45,0	7,5		
PBD72H200	72	8B	2517	-	291,06	289,69	264,0	120,0	60,0	45,0	7,5		
PBD82H200	82	8B	2517	-	331,49	330,12	312,0	120,0	60,0	45,0	7,5		
PBD84H200	84	8B	2517	-	339,57	338,20	312,0	120,0	60,0	45,0	7,5		
PBD94H200	94	8B	2517	-	380,00	378,63	357,0	120,0	60,0	45,0	7,5		
PBD96H200	96	8B	2517	-	388,08	386,71	357,0	120,0	60,0	45,0	7,5		
PBD106H200	106	8B	2517	-	428,51	427,14	402,0	120,0	60,0	45,0	7,5		
PBD116H200	116	8B	2517	-	468,93	467,56	442,0	120,0	60,0	45,0	7,5		
PBD118H200	118	8B	2517	-	477,02	475,65	457,0	120,0	60,0	45,0	7,5		
PBD120H200	120	8B	2517	-	485,10	483,73	457,0	120,0	60,0	45,0	7,5		

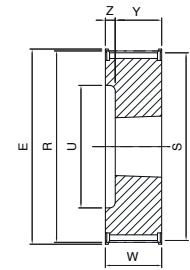

4

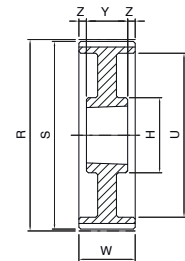

8A

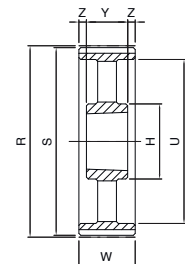

8B

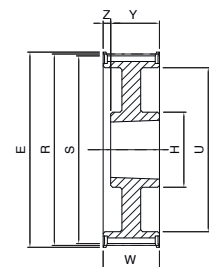

10

Dimensions des poulies dentées, pas en pouces - moyeu amovible SER-SIT®



PBD ... H300

H

Code	Nb de dents	Type	Moyeu amovible SER-SIT®	E [mm]	R [mm]	S [mm]	U [mm]	H [mm]	W [mm]	Y [mm]	Z [mm]	Flasque	Matière
PBD19H300	19	5	1215	82,5	76,81	75,44	56,0	-	84,0	38,0	23,0	avec flasque	fonte
PBD20H300	20	5	1615	87,0	80,85	79,48	62,0	-	84,0	38,0	23,0		
PBD21H300	21	5	1615	91,0	84,89	83,52	62,0	-	84,0	38,0	23,0		
PBD22H300	22	5	1615	94,0	88,94	87,57	62,0	-	84,0	38,0	23,0		
PBD23H300	23	5	1615	97,0	92,98	91,61	71,0	-	84,0	38,0	23,0		
PBD24H300	24	5	1615	102,0	97,02	95,65	71,0	-	84,0	38,0	23,0		
PBD25H300	25	5	1615	106,0	101,06	99,69	79,0	-	84,0	38,0	23,0		
PBD26H300	26	5	1615	112,0	105,11	103,74	79,0	-	84,0	38,0	23,0		
PBD27H300	27	5	2012	115,0	109,15	107,78	86,0	-	84,0	32,0	26,0		
PBD28H300	28	5	2012	120,0	113,19	111,92	86,0	-	84,0	32,0	26,0		
PBD29H300	29	5	2012	120,0	117,23	115,86	95,0	-	84,0	32,0	26,0		
PBD30H300	30	5	2012	128,0	121,28	119,91	95,0	-	84,0	32,0	26,0		
PBD32H300	32	5	2517	135,0	129,36	127,99	110,0	-	84,0	45,0	19,5		
PBD33H300	33	5	2517	142,0	133,40	132,03	112,0	-	84,0	45,0	19,5		
PBD34H300	34	5	2517	142,0	137,45	136,08	112,0	-	84,0	45,0	19,5		
PBD35H300	35	5	2517	150,0	141,49	140,12	120,0	-	84,0	45,0	19,5		
PBD36H300	36	5	2517	150,0	145,53	144,16	120,0	-	84,0	45,0	19,5		
PBD38H300	38	8	2517	158,0	153,62	152,25	136,0	120,0	84,0	45,0	19,5		
PBD40H300	40	8	2517	168,0	161,70	160,33	136,0	120,0	84,0	45,0	19,5		
PBD44H300	44	8	2517	184,0	177,87	176,50	162,0	120,0	86,0	45,0	20,5		
PBD45H300	45	8	2517	192,0	181,91	180,54	162,0	120,0	86,0	45,0	20,5		
PBD48H300	48	8	2517	200,0	194,04	192,67	168,0	120,0	86,0	45,0	20,5		
PBD49H300	49	8A	2517	-	198,08	196,71	172,0	120,0	86,0	45,0	20,5		
PBD50H300	50	8A	2517	-	202,13	200,76	172,0	120,0	86,0	45,0	20,5		
PBD52H300	52	8A	2517	-	210,21	208,84	185,0	120,0	86,0	45,0	20,5		
PBD60H300	60	8B	2517	-	242,55	241,18	223,0	120,0	86,0	45,0	20,5		
PBD70H300	70	8B	2517	-	282,98	281,61	264,0	120,0	86,0	45,0	20,5		
PBD72H300	72	8B	2517	-	291,06	289,69	264,0	120,0	86,0	45,0	20,5		
PBD82H300	82	8B	2517	-	331,49	330,12	312,0	120,0	86,0	45,0	20,5		
PBD84H300	84	8B	2517	-	339,57	338,20	312,0	120,0	86,0	45,0	20,5		
PBD94H300	94	8B	3030	-	380,00	378,63	357,0	146,0	86,0	76,0	5,0		
PBD96H300	96	8B	3030	-	388,08	386,71	357,0	146,0	86,0	76,0	5,0		
PBD106H300	106	8B	3030	-	428,51	427,14	402,0	146,0	86,0	76,0	5,0		
PBD116H300	116	8B	3030	-	468,93	467,56	442,0	146,0	86,0	76,0	5,0		
PBD118H300	118	8B	3030	-	477,02	475,65	457,0	146,0	86,0	76,0	5,0		
PBD120H300	120	8B	3030	-	485,10	483,73	457,0	146,0	86,0	76,0	5,0		

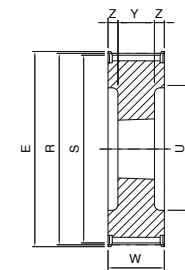

5

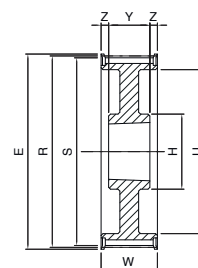

8

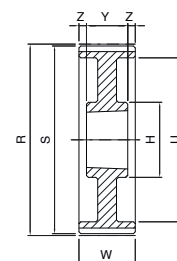

8A

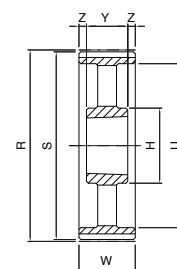

8B

Dimensions des poulies dentées, pas en pouces - moyeu amovible SER-SIT®



PBD ... XH200

XH

Code	Nb de dents	Type	Moyeu amovible SER-SIT®	E [mm]	R [mm]	S [mm]	U [mm]	H [mm]	W [mm]	Y [mm]	Z [mm]	Flasque	Matière
PBD18XH200	18	4	2517	134,0	127,34	124,55	95,0	-	64,0	45,0	19,0	avec flasque	fonte
PBD19XH200	19	4	2517	142,0	134,41	131,62	101,0	-	64,0	45,0	19,0		
PBD20XH200	20	4	2517	150,0	141,49	138,70	101,0	-	64,0	45,0	19,0		
PBD21XH200	21	4	2517	158,0	148,56	145,77	115,0	-	64,0	45,0	19,0		
PBD22XH200	22	4	2517	166,0	155,64	152,85	115,0	-	64,0	45,0	19,0		
PBD24XH200	24	4	2517	177,0	169,79	167,00	129,0	-	64,0	45,0	19,0		
PBD25XH200	25	4	2517	186,0	176,86	174,07	143,0	-	64,0	45,0	19,0		
PBD26XH200	26	4	2517	191,0	183,94	181,15	143,0	-	64,0	45,0	19,0		
PBD27XH200	27	8	2517	200,0	191,01	188,22	157,0	120,0	64,0	45,0	9,5		
PBD28XH200	28	8	2517	209,0	198,08	195,29	157,0	120,0	64,0	45,0	9,5		
PBD30XH200	30	8	2517	216,0	212,23	209,44	180,0	120,0	64,0	45,0	9,5		
PBD32XH200	32	8	2517	232,0	226,38	223,59	195,0	120,0	64,0	45,0	9,5		
PBD34XH200	34	8	2517	261,0	240,53	237,74	208,0	120,0	64,0	45,0	9,5		
PBD38XH200	38	8	2517	274,0	268,83	266,03	234,0	120,0	64,0	45,0	9,5		
PBD40XH200	40	8	3020	288,0	282,98	280,19	242,0	146,0	64,0	51,0	6,5		
PBD46XH200	46	8B	3020	-	325,42	322,63	285,0	146,0	64,0	51,0	6,5		
PBD48XH200	48	8B	3020	-	339,57	336,78	299,0	146,0	64,0	51,0	6,5		
PBD58XH200	58	8B	3020	-	410,32	407,52	370,0	146,0	64,0	51,0	6,5		
PBD60XH200	60	11B	3535	-	424,47	421,68	384,0	178,0	64,0	89,0	12,5		
PBD70XH200	70	11B	3535	-	495,21	492,42	455,0	178,0	64,0	89,0	12,5		
PBD72XH200	72	11B	3535	-	509,36	506,57	469,0	178,0	64,0	89,0	12,5		
PBD78XH200	78	11B	3535	-	551,80	549,01	511,0	178,0	64,0	89,0	12,5		
PBD80XH200	80	11B	3535	-	565,95	563,16	525,0	178,0	64,0	89,0	12,5		
PBD82XH200	82	11B	3535	-	580,10	577,31	539,0	178,0	64,0	89,0	12,5		
PBD84XH200	84	11B	3535	-	594,25	591,46	554,0	178,0	64,0	89,0	12,5		

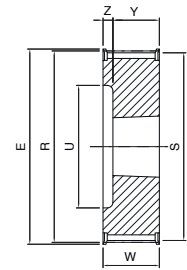

4

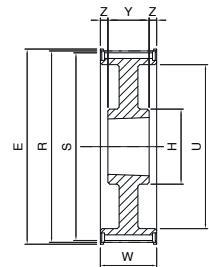

8

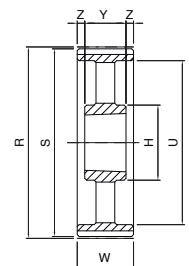

8B

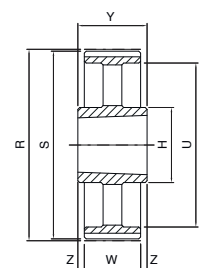

11B

Dimensions des poulies dentées, pas en pouces - moyeu amovible SER-SIT®



PBD ... XH300

XH

Code	Nb de dents	Type	Moyeu amovible SER-SIT®	E [mm]	R [mm]	S [mm]	U [mm]	H [mm]	W [mm]	Y [mm]	Z [mm]	Flasque	Matière
PBD18XH300	18	4	2517	134,0	127,34	124,55	95,0	-	90,0	45,0	45,0	avec flasque	fonte
PBD19XH300	19	4	2517	142,0	134,41	131,62	95,0	-	90,0	45,0	45,0		
PBD20XH300	20	4	2517	150,0	141,49	138,70	101,0	-	90,0	45,0	45,0		
PBD21XH300	21	4	2517	158,0	148,56	145,77	115,0	-	90,0	45,0	45,0		
PBD22XH300	22	4	2517	166,0	155,64	152,85	115,0	-	90,0	45,0	45,0		
PBD24XH300	24	4	2517	177,0	169,79	167,00	129,0	-	90,0	45,0	45,0		
PBD25XH300	25	4	2517	186,0	176,86	174,07	143,0	-	90,0	45,0	45,0		
PBD26XH300	26	4	2517	191,0	183,94	181,15	143,0	-	90,0	45,0	45,0		
PBD27XH300	27	10	3020	200,0	191,01	188,22	157,0	146,0	90,0	51,0	39,0		
PBD28XH300	28	10	3020	209,0	198,08	195,29	157,0	146,0	90,0	51,0	39,0		
PBD30XH300	30	10	3020	216,0	212,23	209,44	172,0	146,0	90,0	51,0	39,0		
PBD32XH300	32	10	3020	232,0	226,38	223,59	186,0	146,0	90,0	51,0	39,0		
PBD34XH300	34	10	3020	261,0	240,53	237,74	200,0	146,0	90,0	51,0	39,0		
PBD38XH300	38	10	3020	274,0	268,83	266,03	228,0	146,0	90,0	51,0	39,0		
PBD40XH300	40	8	3020	288,0	282,98	280,19	245,0	146,0	90,0	51,0	19,5		
PBD46XH300	46	8A	3020	-	325,42	322,63	285,0	146,0	90,0	51,0	19,5		
PBD48XH300	48	8A	3020	-	339,57	336,78	299,0	146,0	90,0	51,0	19,5		
PBD58XH300	58	8A	3535	-	410,32	407,52	370,0	178,0	90,0	89,0	0,5		
PBD60XH300	60	8A	3535	-	424,47	421,68	384,0	178,0	90,0	89,0	0,5		
PBD70XH300	70	8B	3535	-	495,21	492,42	455,0	178,0	90,0	89,0	0,5		
PBD72XH300	72	8B	3535	-	509,36	506,57	469,0	178,0	90,0	89,0	0,5		
PBD78XH300	78	8B	3535	-	551,80	549,01	511,0	178,0	90,0	89,0	0,5		
PBD80XH300	80	8B	3535	-	565,95	563,16	525,0	178,0	90,0	89,0	0,5		
PBD82XH300	82	8B	3535	-	580,10	577,31	539,0	178,0	90,0	89,0	0,5		
PBD84XH300	84	11B	4040	-	594,25	591,46	554,0	215,0	90,0	102,0	6,0		

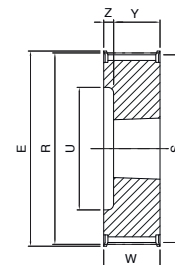

4

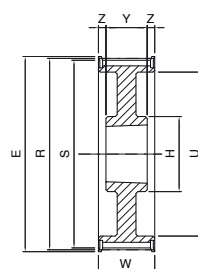

8

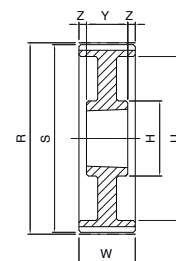

8A

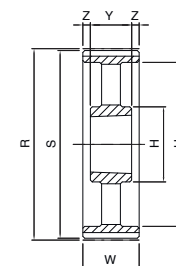

8B

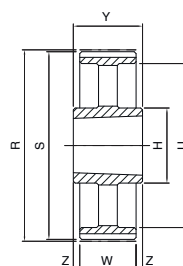

11B

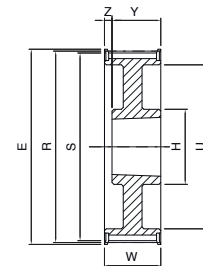

10

Dimensions des poulies dentées, pas en pouces - moyeu amovible SER-SIT®



PBD ... XH400

XH

Code	Nb de dents	Type	Moyeu amovible SER-SIT®	E [mm]	R [mm]	S [mm]	U [mm]	H [mm]	W [mm]	Y [mm]	Z [mm]	Flasque	Matière
PBD18XH400	18	4	2517	134,0	127,34	124,55	95,0	-	119,0	45,0	74,0	avec flasque	fonte
PBD19XH400	19	4	2517	142,0	134,41	131,62	95,0	-	119,0	45,0	74,0		
PBD20XH400	20	4	2517	150,0	141,49	138,70	101,0	-	119,0	45,0	74,0		
PBD21XH400	21	4	2517	158,0	148,56	145,77	115,0	-	119,0	45,0	74,0		
PBD22XH400	22	4	2517	166,0	155,64	152,85	115,0	-	119,0	45,0	74,0		
PBD24XH400	24	4	3020	177,0	169,79	167,00	129,0	-	119,0	51,0	68,0		
PBD25XH400	25	4	3020	186,0	176,86	174,07	143,0	-	119,0	51,0	68,0		
PBD26XH400	26	4	3020	191,0	183,94	181,15	143,0	-	119,0	51,0	68,0		
PBD27XH400	27	4	3020	200,0	191,01	188,22	157,0	-	119,0	51,0	68,0		
PBD28XH400	28	4	3020	209,0	198,08	195,29	157,0	-	119,0	51,0	68,0		
PBD30XH400	30	10	3020	216,0	212,23	209,44	172,0	146,0	119,0	51,0	68,0		
PBD32XH400	32	10	3020	232,0	226,38	223,59	186,0	146,0	119,0	51,0	68,0		
PBD34XH400	34	10	3020	261,0	240,53	237,74	200,0	146,0	119,0	51,0	68,0		
PBD38XH400	38	10	3020	274,0	268,83	266,03	228,0	146,0	119,0	51,0	68,0		
PBD40XH400	40	8	3535	288,0	282,98	280,19	242,0	178,0	119,0	89,0	15,0		
PBD46XH400	46	8A	3535	-	325,42	322,63	285,0	178,0	119,0	89,0	15,0		
PBD48XH400	48	8A	3535	-	339,57	336,78	299,0	178,0	119,0	89,0	15,0		
PBD58XH400	58	8B	3535	-	410,32	407,52	370,0	178,0	119,0	89,0	15,0		
PBD60XH400	60	8B	4040	-	424,47	421,68	384,0	215,0	119,0	102,0	8,5		
PBD70XH400	70	8B	4040	-	495,21	492,42	455,0	215,0	119,0	102,0	8,5		
PBD72XH400	72	8B	4040	-	509,36	506,57	469,0	215,0	119,0	102,0	8,5		
PBD78XH400	78	8B	4040	-	551,80	549,01	511,0	215,0	119,0	102,0	8,5		
PBD80XH400	80	8B	4040	-	565,95	563,16	525,0	215,0	119,0	102,0	8,5		
PBD82XH400	82	8B	4040	-	580,10	577,31	539,0	215,0	119,0	102,0	8,5		
PBD84XH400	84	8B	4040	-	594,25	591,46	554,0	215,0	119,0	102,0	8,5		

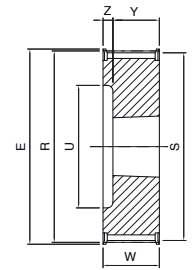

4

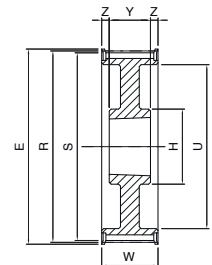

8

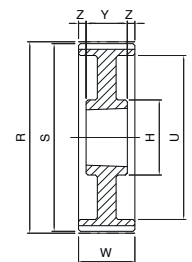

8A

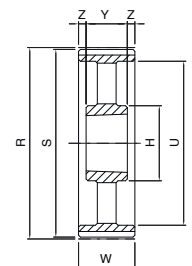

8B

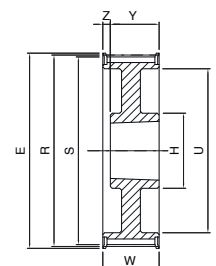

10

Les poulies dentées standard en pas métrique, en exécution à moyeu plein, sont en aluminium.

Moyeu plein

Matière : aluminium

- Pas :
- T 2,5
 - T 5
 - T 10
 - AT5
 - AT 10



Moyeu plein

Matière : sur demande

- Pas :
- T20
 - AT 20



Exécutions spéciales

Sur demande, SIT est capable de concevoir et fabriquer tout type de poulie selon les exigences du client.

Pour les exécutions standard, la forme des dents et les jeux conséquents sont liés au nombre de dents.

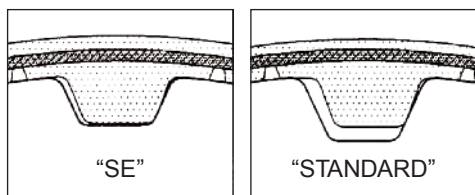

Z < 20

Z > 20

SE: jeu réduit

Sur demande, dans le cas d'applications très précises (par exemple, systèmes de positionnement), une version "sans jeu" peut être fournie.

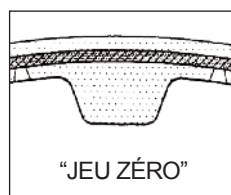

Sur demande

TOLÉRANCES

Tolérances du diamètre de la poulie

Diamètre externe [mm]	Tolérances [mm]
jusqu'à 25,4	-0,05 +0,00
de 25,5 à 50,8	-0,08 +0,00
de 50,9 à 102	-0,10 +0,00
de 103 à 178	-0,13 +0,00
de 179 à 305	-0,15 +0,00
de 306 à 509	-0,18 +0,00
de 510 à 761	-0,20 +0,00
de 762 à 1015	-0,23 +0,00
plus de 1016	-0,25 +0,00

Tolérance d'excentration maxi entre l'alésage et le diamètre extérieur

Diamètre externe [mm]	Excentricité totale mesurée [mm]
jusqu'à 203,2	0,13
plus de 203,2	Ajoutez 0,013 pour 25,4 de diamètre

Oscillation latérale ou voilage

Largeur de la poulie	Tolérances
par 100 mm	0,1 mm sans dépasser la tolérance de diamètre extérieur

Poulies à flasque

Les courroies dentées, lorsqu'elles sont en mouvement, se déplacent légèrement latéralement. Il est donc nécessaire d'utiliser au moins une poulie à flasque pour empêcher la courroie de sortir de la poulie.

Habituellement, afin de réduire les coûts, la flasque est celle de plus petit diamètre.

Cependant, lorsque la distance des axes est supérieure à 8 fois le diamètre de la petite poulie, ou lorsque la transmission s'effectue par des arbres disposés non horizontalement, les deux poulies doivent avoir des flasques.

Revêtement de protection

La durée de vie standard des poulies en aluminium peut être réduite car le revêtement en nylon des dents de la courroie a un effet légèrement abrasif.

Cet inconvénient peut être évité par un chromage de la denture de la poulie.

Note

En raison de l'amélioration constante de nos produits, les données techniques des poulies peuvent faire l'objet de modifications.

Dimensions des poulies dentées SIT, pas métrique "T"

- moyeu plein

Types T 2,5 - T 5 - T 10 - T 20



Désignation	PDMT 16 T2,5 /12
Poulies dentées, pas métrique "T"	
Largeur totale (mm)	
Pas	
Nombre de dents	

T 2,5

Code	Nb de dents	Type	E [mm]	R [mm]	S [mm]	H [mm]	W [mm]	Y [mm]	Z [mm]	Matière
PDMT 16 T2,5/12	12	2	13,0	9,55	9,05	13,0	9,0	16,0	7,0	aluminium
PDMT 16 T2,5/14	14	2	15,0	11,14	10,64	15,0	9,0	16,0	7,0	
PDMT 16 T2,5/15	15	2	15,0	11,94	11,44	15,0	9,0	16,0	7,0	
PDMT 16 T2,5/16	16	2	16,0	12,73	12,23	16,0	10,0	16,0	6,0	
PDMT 16 T2,5/18	18	1	17,5	14,32	13,82	10,0	10,0	16,0	6,0	
PDMT 16 T2,5/19	19	1	20,0	15,12	14,62	10,0	10,0	16,0	6,0	
PDMT 16 T2,5/20	20	1	20,0	15,92	15,41	11,0	10,0	16,0	6,0	
PDMT 16 T2,5/22	22	1	22,0	17,51	17,01	11,0	10,0	16,0	6,0	
PDMT 16 T2,5/24	24	1	22,0	19,10	18,60	12,0	10,0	16,0	6,0	
PDMT 16 T2,5/25	25	1	23,0	19,89	19,39	13,0	10,0	16,0	6,0	
PDMT 16 T2,5/26	26	1	26,0	20,69	20,19	14,0	10,0	16,0	6,0	
PDMT 16 T2,5/28	28	1	26,0	22,28	21,78	14,0	10,0	16,0	6,0	
PDMT 16 T2,5/30	30	1	28,0	23,87	23,37	16,0	10,0	16,0	6,0	
PDMT 16 T2,5/32	32	1	32,0	25,46	24,96	16,0	10,0	16,0	6,0	
PDMT 16 T2,5/36	36	1	36,0	28,65	28,15	20,0	10,0	16,0	6,0	
PDMT 16 T2,5/40	40	1	38,0	31,83	31,33	22,0	10,0	16,0	6,0	
PDMT 16 T2,5/44	44	1	42,0	35,01	34,51	24,0	10,0	16,0	6,0	
PDMT 16 T2,5/48	48	1A	-	38,20	37,70	26,0	10,0	16,0	6,0	
PDMT 16 T2,5/60	60	1A	-	47,75	47,25	34,0	10,0	16,0	6,0	

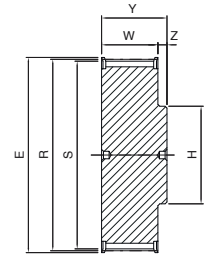

1

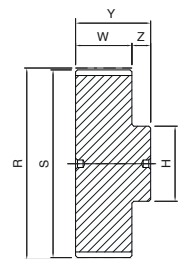

1A

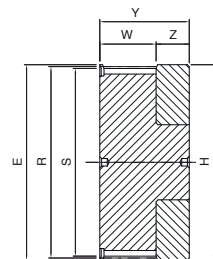

2

T 5

Code	Nb de dents	Type	E [mm]	R [mm]	S [mm]	H [mm]	Largeur de la courroie						Z [mm]	Matière
							10 mm		16 mm		25 mm			
							W [mm]	Y [mm]	W [mm]	Y [mm]	W [mm]	Y [mm]		
PDMT coteY T5/10	10	1	19,50	15,92	15,07	8,0	15,0	21,0	21,0	27,0	30,0	36,0	6,0	aluminium
PDMT coteY T5/12	12	1	23,00	19,10	18,26	11,0	15,0	21,0	21,0	27,0	30,0	36,0	6,0	
PDMT coteY T5/14	14	1	25,00	22,28	21,44	13,0	15,0	21,0	21,0	27,0	30,0	36,0	6,0	
PDMT coteY T5/15	15	1	28,00	23,87	23,03	16,0	15,0	21,0	21,0	27,0	30,0	36,0	6,0	
PDMT coteY T5/16	16	1	32,00	25,46	24,62	18,0	15,0	21,0	21,0	27,0	30,0	36,0	6,0	
PDMT coteY T5/18	18	1	32,00	28,65	27,81	20,0	15,0	21,0	21,0	27,0	30,0	36,0	6,0	
PDMT coteY T5/19	19	1	36,00	30,24	29,40	20,0	15,0	21,0	21,0	27,0	30,0	36,0	6,0	
PDMT coteY T5/20	20	1	36,00	31,83	30,99	22,0	15,0	21,0	21,0	27,0	30,0	36,0	6,0	
PDMT coteY T5/22	22	1	38,00	35,01	34,17	23,0	15,0	21,0	21,0	27,0	30,0	36,0	6,0	
PDMT coteY T5/24	24	1	42,00	38,20	37,36	24,0	15,0	21,0	21,0	27,0	30,0	36,0	6,0	
PDMT coteY T5/25	25	1	44,00	39,79	38,95	26,0	15,0	21,0	21,0	27,0	30,0	36,0	6,0	
PDMT coteY T5/26	26	1	44,00	41,38	40,54	26,0	15,0	21,0	21,0	27,0	30,0	36,0	6,0	
PDMT coteY T5/27	27	1	48,00	42,97	42,13	30,0	15,0	21,0	21,0	27,0	30,0	36,0	6,0	
PDMT coteY T5/28	28	1	48,00	44,56	43,72	32,0	15,0	21,0	21,0	27,0	30,0	36,0	6,0	
PDMT coteY T5/30	30	1	51,00	47,75	46,91	34,0	15,0	21,0	21,0	27,0	30,0	36,0	6,0	
PDMT coteY T5/32	32	1	54,00	50,93	50,09	38,0	15,0	21,0	21,0	27,0	30,0	36,0	6,0	
PDMT coteY T5/36	36	1	64,00	57,30	56,46	38,0	15,0	21,0	21,0	27,0	30,0	36,0	6,0	
PDMT coteY T5/40	40	1	66,50	63,66	62,82	40,0	15,0	21,0	21,0	27,0	30,0	36,0	6,0	
PDMT coteY T5/42	42	1	70,00	66,85	66,00	40,0	15,0	21,0	21,0	27,0	30,0	36,0	6,0	
PDMT coteY T5/44	44	1A	-	70,03	69,19	45,0	15,0	21,0	21,0	27,0	30,0	36,0	6,0	
PDMT coteY T5/48	48	1A	-	76,39	75,55	50,0	15,0	21,0	21,0	27,0	30,0	36,0	6,0	
PDMT coteY T5/60	60	1A	-	95,49	94,65	65,0	15,0	21,0	21,0	27,0	30,0	36,0	6,0	

Dimensions des poulies dentées SIT, pas métrique "T" - moyeu plein



T 10

Code	Nb de dents	Type	E [mm]	R [mm]	S [mm]	U [mm]	H [mm]	Largeur de la courroie								Z [mm]	Matière
								16 mm		25 mm		32 mm		50 mm			
								W [mm]	Y [mm]	W [mm]	Y [mm]	W [mm]	Y [mm]	W [mm]	Y [mm]		
PDMT coteY T10/12	12	1	42,0	38,20	36,34	-	28,0	21,0	31,0	30,0	40,0	-	-	-	-	10,0	aluminum
PDMT coteY T10/14	14	1	48,0	44,56	42,70	-	32,0	21,0	31,0	30,0	40,0	-	-	-	-	10,0	
PDMT coteY T10/15	15	1	51,0	47,75	45,89	-	32,0	21,0	31,0	30,0	40,0	-	-	-	-	10,0	
PDMT coteY T10/16	16	1	54,0	50,93	49,07	-	35,0	21,0	31,0	30,0	40,0	-	-	-	-	10,0	
PDMT coteY T10/18	18	1	60,0	57,30	55,44	-	40,0	21,0	31,0	30,0	40,0	37,0	47,0	56,0	66,0	10,0	
PDMT coteY T10/19	19	1	66,0	60,48	58,62	-	44,0	21,0	31,0	30,0	40,0	37,0	47,0	56,0	66,0	10,0	
PDMT coteY T10/20	20	1	66,0	63,66	61,80	-	46,0	21,0	31,0	30,0	40,0	37,0	47,0	56,0	66,0	10,0	
PDMT coteY T10/22	22	1	75,0	70,03	68,17	-	52,0	21,0	31,0	30,0	40,0	37,0	47,0	56,0	66,0	10,0	
PDMT coteY T10/24	24	1	83,0	76,39	74,53	-	58,0	21,0	31,0	30,0	40,0	37,0	47,0	56,0	66,0	10,0	
PDMT coteY T10/25	25	1	83,0	79,58	77,72	-	60,0	21,0	31,0	30,0	40,0	37,0	47,0	56,0	66,0	10,0	
PDMT coteY T10/26	26	1	87,0	82,76	80,90	-	60,0	21,0	31,0	30,0	40,0	37,0	47,0	56,0	66,0	10,0	
PDMT coteY T10/27	27	1	91,0	85,94	84,08	-	60,0	21,0	31,0	30,0	40,0	37,0	47,0	56,0	66,0	10,0	
PDMT coteY T10/28	28	1	93,0	89,13	87,27	-	60,0	21,0	31,0	30,0	40,0	37,0	47,0	56,0	66,0	10,0	
PDMT coteY T10/30	30	1	97,0	95,49	93,63	-	60,0	21,0	31,0	30,0	40,0	37,0	47,0	56,0	66,0	10,0	
PDMT coteY T10/32	32	1	106,0	101,86	100,00	-	65,0	21,0	31,0	30,0	40,0	37,0	47,0	56,0	66,0	10,0	
PDMT coteY T10/36	36	1	119,0	114,59	112,73	-	70,0	21,0	31,0	30,0	40,0	37,0	47,0	56,0	66,0	10,0	
PDMT coteY T10/40	40	1	131,0	127,32	125,46	-	80,0	21,0	31,0	30,0	40,0	37,0	47,0	56,0	66,0	10,0	
PDMT coteY T10/44	44	3A	-	140,06	138,20	118,0	88,0	21,0	31,0	30,0	40,0	37,0	47,0	56,0	66,0	10,0	
PDMT coteY T10/48	48	3A	-	152,79	150,93	130,0	95,0	21,0	31,0	30,0	40,0	37,0	47,0	56,0	66,0	10,0	
PDMT coteY T10/60	60	3A	-	190,99	189,13	165,0	110,0	21,0	31,0	30,0	40,0	37,0	47,0	56,0	66,0	10,0	

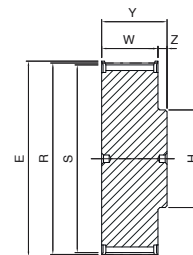

1

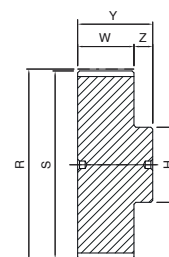

1A

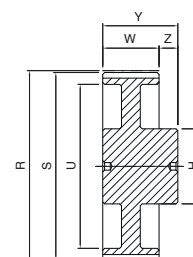

3A

T 20

Code	Nb de dents	Type	E [mm]	R [mm]	S [mm]	U [mm]	H [mm]	d Ø	Largeur de la courroie									Matière
									32 mm			50 mm			100 mm			
									W [mm]	Y [mm]	Z [mm]	W [mm]	Y [mm]	Z [mm]	W [mm]	Y [mm]	Z [mm]	
PDMT coteY T20/18	18	1	118,0	114,59	111,74	-	80,0	-	42,0	53,0	11,0	60,0	71,0	11,0	110,0	123,0	13,0	sur demande
PDMT coteY T20/20	20	1	134,0	127,32	124,47	-	90,0	-	42,0	53,0	11,0	60,0	71,0	11,0	110,0	123,0	13,0	
PDMT coteY T20/22	22	1	150,0	140,06	137,21	-	90,0	-	42,0	53,0	11,0	60,0	71,0	11,0	110,0	123,0	13,0	
PDMT coteY T20/24	24	1	158,0	152,79	149,94	-	95,0	-	42,0	53,0	11,0	60,0	71,0	11,0	110,0	123,0	13,0	
PDMT coteY T20/25	25	1	166,0	159,15	156,30	-	95,0	-	42,0	53,0	11,0	60,0	71,0	11,0	110,0	123,0	13,0	
PDMT coteY T20/30	30	1	200,0	190,99	188,14	-	110,0	-	42,0	53,0	11,0	60,0	71,0	11,0	110,0	123,0	13,0	
PDMT coteY T20/32	32	1A	-	203,72	200,87	-	110,0	-	42,0	53,0	11,0	60,0	71,0	11,0	110,0	123,0	13,0	
PDMT coteY T20/36	36	1A	-	229,18	226,33	-	110,0	-	42,0	53,0	11,0	60,0	71,0	11,0	110,0	123,0	13,0	
PDMT coteY T20/40	40	3A	-	254,65	251,80	210,0	110,0	-	42,0	53,0	11,0	60,0	71,0	11,0	110,0	123,0	13,0	
PDMT coteY T20/48	48	3A	-	305,58	302,73	260,0	130,0	-	42,0	53,0	11,0	60,0	71,0	11,0	110,0	123,0	13,0	
PDMT coteY T20/60	60	3A	-	381,97	379,12	338,0	130,0	22,0	42,0	53,0	11,0	60,0	71,0	11,0	110,0	123,0	13,0	
PDMT coteY T20/72	72	3A	-	458,37	455,52	415,0	140,0	22,0	42,0	53,0	11,0	60,0	71,0	11,0	110,0	123,0	13,0	

Dimensions des poulies dentées, pas métrique «AT» - moyeu plein

Types AT 5 - AT 10 - AT 20

Désignation	PMAT 16 AT5 /12
Poulies dentées, pas métrique"AT"	
Largeur totale(mm)	
Pas	
Nombre de dents	

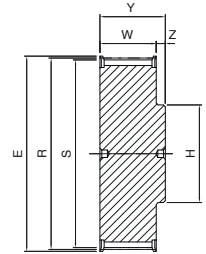

1

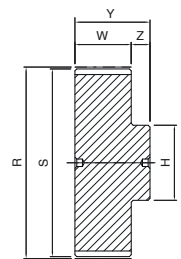

1A

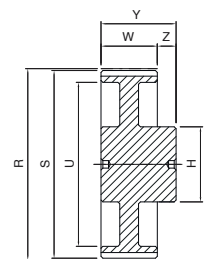

3A

AT 5

Code	Nb de dents	Type	E [mm]	R [mm]	S [mm]	H [mm]	Largeur de la courroie						Z [mm]	Matière
							10 mm		16 mm		25 mm			
							W [mm]	Y [mm]	W [mm]	Y [mm]	W [mm]	Y [mm]		
PMAT coteY AT5/12	12	1	23,0	19,10	17,88	11,0	15,0	21,0	21,0	27,0	30,0	36,0	6,0	aluminium
PMAT coteY AT5/14	14	1	25,0	22,28	21,06	14,0	15,0	21,0	21,0	27,0	30,0	36,0	6,0	
PMAT coteY AT5/15	15	1	28,0	23,87	22,65	16,0	15,0	21,0	21,0	27,0	30,0	36,0	6,0	
PMAT coteY AT5/16	16	1	32,0	25,46	24,24	18,0	15,0	21,0	21,0	27,0	30,0	36,0	6,0	
PMAT coteY AT5/18	18	1	32,0	28,65	27,43	20,0	15,0	21,0	21,0	27,0	30,0	36,0	6,0	
PMAT coteY AT5/19	19	1	36,0	30,24	29,02	22,0	15,0	21,0	21,0	27,0	30,0	36,0	6,0	
PMAT coteY AT5/20	20	1	36,0	31,83	30,61	23,0	15,0	21,0	21,0	27,0	30,0	36,0	6,0	
PMAT coteY AT5/22	22	1	38,0	35,01	33,79	24,0	15,0	21,0	21,0	27,0	30,0	36,0	6,0	
PMAT coteY AT5/24	24	1	42,0	38,20	36,98	26,0	15,0	21,0	21,0	27,0	30,0	36,0	6,0	
PMAT coteY AT5/25	25	1	44,0	39,79	38,57	26,0	15,0	21,0	21,0	27,0	30,0	36,0	6,0	
PMAT coteY AT5/26	26	1	44,0	41,38	40,16	26,0	15,0	21,0	21,0	27,0	30,0	36,0	6,0	
PMAT coteY AT5/27	27	1	48,0	42,97	41,75	30,0	15,0	21,0	21,0	27,0	30,0	36,0	6,0	
PMAT coteY AT5/28	28	1	48,0	44,56	43,34	32,0	15,0	21,0	21,0	27,0	30,0	36,0	6,0	
PMAT coteY AT5/30	30	1	51,0	47,75	46,53	34,0	15,0	21,0	21,0	27,0	30,0	36,0	6,0	
PMAT coteY AT5/32	32	1	54,0	50,93	49,71	36,0	15,0	21,0	21,0	27,0	30,0	36,0	6,0	
PMAT coteY AT5/36	36	1	64,0	57,30	56,08	38,0	15,0	21,0	21,0	27,0	30,0	36,0	6,0	
PMAT coteY AT5/40	40	1	67,0	63,66	62,44	40,0	15,0	21,0	21,0	27,0	30,0	36,0	6,0	
PMAT coteY AT5/42	42	1	70,0	66,85	65,62	40,0	15,0	21,0	21,0	27,0	30,0	36,0	6,0	
PMAT coteY AT5/44	44	1A	-	70,03	68,81	45,0	15,0	21,0	21,0	27,0	30,0	36,0	6,0	
PMAT coteY AT5/48	48	1A	-	76,39	75,17	50,0	15,0	21,0	21,0	27,0	30,0	36,0	6,0	
PMAT coteY AT5/60	60	1A	-	95,49	94,27	65,0	15,0	21,0	21,0	27,0	30,0	36,0	6,0	

AT 10

Code	Nb de dents	Type	E [mm]	R [mm]	S [mm]	U [mm]	H [mm]	Largeur de la courroie								Z [mm]	Matière
								16 mm		25 mm		32 mm		50 mm			
								W [mm]	Y [mm]	W [mm]	Y [mm]	W [mm]	Y [mm]	W [mm]	Y [mm]		
PMAT coteY AT10/15	15	1	51,0	47,75	45,93	-	31,0	21,0	31,0	30,0	40,0	-	-	-	-	10,0	aluminium
PMAT coteY AT10/16	16	1	54,0	50,93	49,11	-	35,0	21,0	31,0	30,0	40,0	-	-	-	-	10,0	
PMAT coteY AT10/18	18	1	60,0	57,3	55,48	-	40,0	21,0	31,0	30,0	40,0	37,0	47,0	56,0	66,0	10,0	
PMAT coteY AT10/19	19	1	66,0	60,48	58,66	-	44,0	21,0	31,0	30,0	40,0	37,0	47,0	56,0	66,0	10,0	
PMAT coteY AT10/20	20	1	66,0	63,66	61,84	-	46,0	21,0	31,0	30,0	40,0	37,0	47,0	56,0	66,0	10,0	
PMAT coteY AT10/22	22	1	75,0	70,03	68,21	-	52,0	21,0	31,0	30,0	40,0	37,0	47,0	56,0	66,0	10,0	
PMAT coteY AT10/24	24	1	83,0	76,39	74,57	-	58,0	21,0	31,0	30,0	40,0	37,0	47,0	56,0	66,0	10,0	
PMAT coteY AT10/25	25	1	83,0	79,58	77,76	-	60,0	21,0	31,0	30,0	40,0	37,0	47,0	56,0	66,0	10,0	
PMAT coteY AT10/26	26	1	87,0	82,76	80,94	-	60,0	21,0	31,0	30,0	40,0	37,0	47,0	56,0	66,0	10,0	
PMAT coteY AT10/27	27	1	91,0	85,94	84,12	-	60,0	21,0	31,0	30,0	40,0	37,0	47,0	56,0	66,0	10,0	
PMAT coteY AT10/28	28	1	93,0	89,13	87,31	-	60,0	21,0	31,0	30,0	40,0	37,0	47,0	56,0	66,0	10,0	
PMAT coteY AT10/30	30	1	97,0	95,49	93,67	-	60,0	21,0	31,0	30,0	40,0	37,0	47,0	56,0	66,0	10,0	
PMAT coteY AT10/32	32	1	106,0	101,86	100,04	-	65,0	21,0	31,0	30,0	40,0	37,0	47,0	56,0	66,0	10,0	
PMAT coteY AT10/36	36	1	119,0	114,59	112,77	-	70,0	21,0	31,0	30,0	40,0	37,0	47,0	56,0	66,0	10,0	
PMAT coteY AT10/40	40	1	131,0	127,32	125,50	-	80,0	21,0	31,0	30,0	40,0	37,0	47,0	56,0	66,0	10,0	
PMAT coteY AT10/44	44	3A	-	140,06	138,24	118,0	88,0	21,0	31,0	30,0	40,0	37,0	47,0	56,0	66,0	10,0	
PMAT coteY AT10/48	48	3A	-	152,79	150,97	130,0	95,0	21,0	31,0	30,0	40,0	37,0	47,0	56,0	66,0	10,0	
PMAT coteY AT10/60	60	3A	-	190,99	189,17	165,0	110,0	21,0	31,0	30,0	40,0	37,0	47,0	56,0	66,0	10,0	

Dimensions des poulies dentées, pas métrique «AT» - moyeu plein



AT 20

Code	Nb de dents	Type	E [mm]	R [mm]	S [mm]	U [mm]	H [mm]	d Ø	Largeur de la courroie									Matière
									32 mm			50 mm			100 mm			
									W [mm]	Y [mm]	Z [mm]	W [mm]	Y [mm]	Z [mm]	W [mm]	Y [mm]	Z [mm]	
PMAT coteY AT20/18	18	1	118,0	114,59	111,77	-	80,0	-	42,0	53,0	11,0	60,0	71,0	11,0	110,0	123,0	13,0	sur demande
PMAT coteY AT20/20	20	1	134,0	127,32	124,50	-	90,0	-	42,0	53,0	11,0	60,0	71,0	11,0	110,0	123,0	13,0	
PMAT coteY AT20/22	22	1	150,0	140,06	137,24	-	90,0	-	42,0	53,0	11,0	60,0	71,0	11,0	110,0	123,0	13,0	
PMAT coteY AT20/24	24	1	158,0	152,79	149,97	-	95,0	-	42,0	53,0	11,0	60,0	71,0	11,0	110,0	123,0	13,0	
PMAT coteY AT20/25	25	1	166,0	159,15	156,33	-	95,0	-	42,0	53,0	11,0	60,0	71,0	11,0	110,0	123,0	13,0	
PMAT coteY AT20/30	30	1	200,0	190,99	188,17	-	110,0	-	42,0	53,0	11,0	60,0	71,0	11,0	110,0	123,0	13,0	
PMAT coteY AT20/32	32	1A	-	203,72	200,90	-	110,0	-	42,0	53,0	11,0	60,0	71,0	11,0	110,0	123,0	13,0	
PMAT coteY AT20/36	36	1A	-	229,18	226,36	-	110,0	-	42,0	53,0	11,0	60,0	71,0	11,0	110,0	123,0	13,0	
PMAT coteY AT20/40	40	3A	-	254,65	251,83	210,0	110,0	-	42,0	53,0	11,0	60,0	71,0	11,0	110,0	123,0	13,0	
PMAT coteY AT20/48	48	3A	-	305,58	302,76	260,0	130,0	-	42,0	53,0	11,0	60,0	71,0	11,0	110,0	123,0	13,0	
PMAT coteY AT20/60	60	3A	-	381,97	379,15	338,0	130,0	22,0	42,0	53,0	11,0	60,0	71,0	11,0	110,0	123,0	13,0	
PMAT coteY AT20/72	72	3A	-	458,37	455,55	415,0	140,0	22,0	42,0	53,0	11,0	60,0	71,0	11,0	110,0	123,0	13,0	

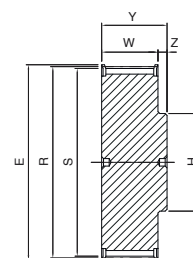

1

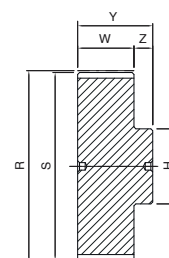

1A

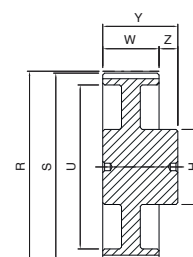

3A

Les poulies TOP DRIVE® HTD ont une conception différente des poulies dentées traditionnelles.

La denture des poulies est prévue pour un engrenement pratiquement sans friction avec la courroie. Les poulies TOP DRIVE® HTD sont disponibles en moyeu plein et pour les assemblages avec moyeux amovibles SER-SIT®.

Moyeu plein

Matière: aluminuM/fonte/acier

Finition: phosphatation au manganèse noir.

Pas :

- 3M
- 5M
- 8M
- 14M



Pour le montage avec moyeux amovibles SER-SIT®

Matière: fonte/acier

Finition: phosphatation au manganèse noir.

Pas :

- 5M
- 8M
- 14M



Exécutions spéciales

Sur demande, SIT est capable de concevoir et fabriquer tout type de poulie selon les exigences du client. Pour une vitesse périphérique supérieure à 33 m / s, il est fortement recommandé d'utiliser l'acier comme matériau de construction.

$$\text{Vitesse périphérique [m/s]} = \frac{\text{diamètre de la poulie [mm]} \times \text{tr/mn}}{19100}$$

Afin de réduire le poids, les poulies peuvent être fabriquées à partir d'alliages. Dans ce cas, leur durée de vie sera réduite, car le revêtement de courroies en nylon a un effet légèrement abrasif. Cet inconvénient peut être évité par un chromage de la denture de la poulie

Flasque

Les courroies dentées, lorsqu'elles sont en mouvement, se déplacent légèrement latéralement. Il est donc nécessaire d'utiliser au moins une poulie à flasques pour empêcher la courroie de sortir de la poulie.

Habituellement, afin de réduire les coûts, la poulie à flasques est celle de plus petit diamètre.

Cependant, lorsque la distance des axes est supérieure à 8 fois le diamètre de la petite poulie, ou lorsque la transmission s'effectue par des arbres disposés non horizontalement, les deux poulies doivent avoir des flasques.

TOLÉRANCES

Tolérances du diamètre de la poulie

Diamètre externe [mm]	Tolérances [mm]
jusqu'à 25,4	-0,00 +0,05
de 25,5 à 50,8	-0,00 +0,08
de 50,9 à 101,6	-0,00 +0,10
de 101,7 à 177,8	-0,00 +0,13
de 177,9 à 304,8	-0,00 +0,15
de 304,9 à 508,0	-0,00 +0,18
plus de 508,1	-0,00 +0,25

Tolérance d'excentration maxi entre l'alésage et le diamètre extérieur

Diamètre externe [mm]	Excentricité totale mesurée [mm]
jusqu'à 200	0,13
plus de 200	ajoutez 0,0005 pour tout diamètre supérieur à 200 mm

Oscillation latérale ou voilage

Largeur de la poulie	Tolérances
par 100 mm	0,1 mm sans dépasser la tolérance de diamètre extérieur

Revêtement de protection

Toutes les poulies (acier et fonte) sont traitées avec un procédé de phosphatation au manganèse noir qui donne une plus grande résistance contre les agents oxydants. Ce traitement ne modifie pas le profil ou les dimensions des poulies.

Sur demande, SIT peut fournir une large gamme de revêtements spéciaux, liés aux besoins ou à des conditions environnementales critiques.

Note

En raison de l'amélioration constante de nos produits, les données techniques des poulies peuvent faire l'objet de modifications.

Dimensions des poulies dentées TOP DRIVE® HTD

- moyeu plein

Types 3M - 5M - 8M - 14M



Désignation	HD 48 -8M 20
Poulies dentées HTD - Moyeu plein	
Nombre de dents	
Pas	
Largeur de la courroie en mm	

HD ... -3M09

3M

Code	Nb de dents	Type	E [mm]	R [mm]	S [mm]	H [mm]	W [mm]	Y [mm]	Z [mm]	Flasque	Matière
HD 10 - 3M 09	10	2	13,0	9,55	8,79	13,0	10,2	17,5	7,3	avec flasque	aluminium
HD 12 - 3M 09	12	2	15,0	11,46	10,70	15,0	10,2	17,5	7,3		
HD 14 - 3M 09	14	2	16,0	13,37	12,61	18,0	10,2	17,5	7,3		
HD 15 - 3M 09	15	2	17,5	14,32	13,56	18,0	10,2	17,5	7,3		
HD 16 - 3M 09	16	1	17,5	15,28	14,52	10,0	12,8	20,6	7,8		
HD 18 - 3M 09	18	1	20,0	17,19	16,43	11,0	12,8	20,6	7,8		
HD 20 - 3M 09	20	1	23,0	19,10	18,34	13,0	12,8	20,6	7,8		
HD 21 - 3M 09	21	1	25,0	20,05	19,29	13,0	12,8	20,6	7,8		
HD 22 - 3M 09	22	1	25,0	21,01	20,25	13,0	12,8	20,6	7,8		
HD 24 - 3M 09	24	1	25,0	22,92	22,16	14,0	12,8	20,6	7,8		
HD 26 - 3M 09	26	1	28,0	24,83	24,07	16,0	12,8	20,6	7,8		
HD 28 - 3M 09	28	1	32,0	26,74	25,98	18,0	12,8	20,6	7,8		
HD 30 - 3M 09	30	1	32,0	28,65	27,89	20,0	12,8	20,6	7,8		
HD 32 - 3M 09	32	1	36,0	30,56	29,80	22,0	12,8	20,6	7,8		
HD 36 - 3M 09	36	1	39,0	34,38	33,62	26,0	13,4	22,2	8,8		
HD 40 - 3M 09	40	1	42,0	38,20	37,44	28,0	13,4	22,2	8,8		
HD 44 - 3M 09	44	1	48,0	42,02	41,26	33,0	13,4	22,2	8,8		
HD 48 - 3M 09	48	1A	-	45,84	45,08	33,0	13,4	22,2	8,8		
HD 60 - 3M 09	60	1A	-	57,30	56,54	33,0	13,4	22,2	8,8		
HD 72 - 3M 09	72	1A	-	68,75	67,99	33,0	13,4	22,2	8,8		

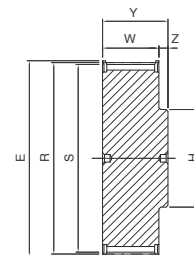

1

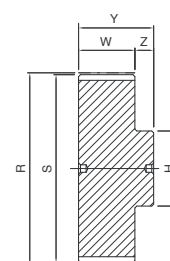

1A

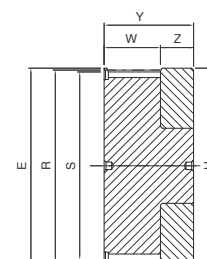

2

HD ... -3M15

3M

Code	Nb de dents	Type	E [mm]	R [mm]	S [mm]	H [mm]	W [mm]	Y [mm]	Z [mm]	Flasque	Matière
HD 10 - 3M 15	10	2	13,0	9,55	8,79	13,0	17,0	26,0	9,0	avec flasque	aluminium
HD 12 - 3M 15	12	2	15,0	11,46	10,70	15,0	17,0	26,0	9,0		
HD 14 - 3M 15	14	2	16,0	13,37	12,61	18,0	17,0	26,0	9,0		
HD 15 - 3M 15	15	2	17,5	14,32	13,56	18,0	17,0	26,0	9,0		
HD 16 - 3M 15	16	1	17,5	15,28	14,52	10,0	19,5	26,0	6,5		
HD 18 - 3M 15	18	1	20,0	17,19	16,43	11,0	19,5	26,0	6,5		
HD 20 - 3M 15	20	1	23,0	19,10	18,34	13,0	19,5	26,0	6,5		
HD 21 - 3M 15	21	1	25,0	20,05	19,29	13,0	19,5	26,0	6,5		
HD 22 - 3M 15	22	1	25,0	21,01	20,25	13,0	19,5	26,0	6,5		
HD 24 - 3M 15	24	1	25,0	22,92	22,16	14,0	19,5	26,0	6,5		
HD 26 - 3M 15	26	1	28,0	24,83	24,07	16,0	19,5	26,0	6,5		
HD 28 - 3M 15	28	1	32,0	26,74	25,98	18,0	19,5	26,0	6,5		
HD 30 - 3M 15	30	1	32,0	28,65	27,89	20,0	19,5	26,0	6,5		
HD 32 - 3M 15	32	1	36,0	30,56	29,80	22,0	19,5	26,0	6,5		
HD 36 - 3M 15	36	1	39,0	34,38	33,62	26,0	20,0	30,0	10,0		
HD 40 - 3M 15	40	1	42,0	38,20	37,44	28,0	20,0	30,0	10,0		
HD 44 - 3M 15	44	1	48,0	42,02	41,26	33,0	20,0	30,0	10,0		
HD 48 - 3M 15	48	1A	-	45,84	45,08	33,0	20,0	30,0	10,0		
HD 60 - 3M 15	60	1A	-	57,30	56,54	33,0	20,0	30,0	10,0		
HD 72 - 3M 15	72	1A	-	68,75	67,99	33,0	20,0	30,0	10,0		

Dimensions des poulies dentées TOP DRIVE® HTD - moyeu plein



HD ... -5M09

5M

Code	Nb de dents	Type	E [mm]	R [mm]	S [mm]	H [mm]	W [mm]	Y [mm]	Z [mm]	Z [mm]	Flasque	Matière
HD 12 - 5M 09	12	1	23,0	19,10	17,96	-	12,0	14,5	20,0	5,5	avec flasque	acier
HD 14 - 5M 09	14	1	25,0	22,28	21,14	-	13,0	14,5	20,0	5,5		
HD 15 - 5M 09	15	1	28,0	23,87	22,73	-	16,0	14,5	20,0	5,5		
HD 16 - 5M 09	16	1	28,0	25,47	24,32	-	16,5	14,5	20,0	5,5		
HD 18 - 5M 09	18	1	32,0	28,65	27,51	-	20,0	14,5	20,0	5,5		
HD 20 - 5M 09	20	1	36,0	31,83	30,69	-	23,0	14,5	22,5	8,0		
HD 21 - 5M 09	21	1	38,0	33,42	32,28	-	24,0	14,5	22,5	8,0		
HD 22 - 5M 09	22	1	39,0	35,01	33,87	-	25,5	14,5	22,5	8,0		
HD 24 - 5M 09	24	1	42,0	38,19	37,06	-	27,0	14,5	22,5	8,0		
HD 26 - 5M 09	26	1	44,0	41,38	40,24	-	30,0	14,5	22,5	8,0		
HD 28 - 5M 09	28	1	48,0	44,56	43,42	-	30,5	14,5	22,5	8,0		
HD 30 - 5M 09	30	1	51,0	47,75	46,61	-	35,0	14,5	22,5	8,0		
HD 32 - 5M 09	32	1	54,0	50,93	49,79	-	38,0	14,5	22,5	8,0		
HD 36 - 5M 09	36	1	60,0	57,30	56,16	-	38,0	14,5	22,5	8,0		
HD 40 - 5M 09	40	1	71,0	63,66	62,52	-	38,0	14,5	22,5	8,0		
HD 44 - 5M 09	44	1A	-	70,03	68,89	-	38,0	14,5	25,5	11,0		
HD 48 - 5M 09	48	1A	-	76,39	75,25	-	45,0	14,5	25,5	11,0		
HD 60 - 5M 09	60	1A	-	95,49	94,35	-	45,0	14,5	25,5	11,0		
HD 72 - 5M 09	72	3A	-	114,59	113,45	90	45,0	14,5	25,5	11,0		

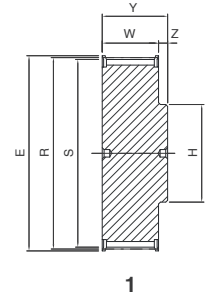

1

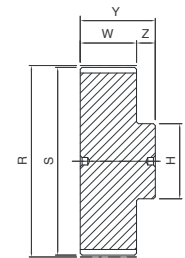

1A

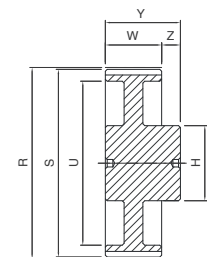

3A

HD ... -5M15

5M

Code	Nb de dents	Type	E [mm]	R [mm]	S [mm]	U [mm]	H [mm]	W [mm]	Y [mm]	Z [mm]	Flasque	Matière
HD 12 - 5M 15	12	1	23,0	19,10	17,96	-	12,0	20,5	26,0	5,5	avec flasque	acier
HD 14 - 5M 15	14	1	25,0	22,28	21,14	-	13,0	20,5	26,0	5,5		
HD 15 - 5M 15	15	1	28,0	23,87	22,73	-	16,0	20,5	26,0	5,5		
HD 16 - 5M 15	16	1	28,0	25,47	24,32	-	16,5	20,5	26,0	5,5		
HD 18 - 5M 15	18	1	32,0	28,65	27,51	-	20,0	20,5	26,0	5,5		
HD 20 - 5M 15	20	1	36,0	31,83	30,69	-	23,0	20,5	26,0	5,5		
HD 21 - 5M 15	21	1	38,0	33,42	32,28	-	24,0	20,5	26,0	5,5		
HD 22 - 5M 15	22	1	39,0	35,01	33,87	-	25,5	20,5	26,0	5,5		
HD 24 - 5M 15	24	1	42,0	38,19	37,06	-	27,0	20,5	28,0	7,5		
HD 26 - 5M 15	26	1	44,0	41,38	40,24	-	30,0	20,5	28,0	7,5		
HD 28 - 5M 15	28	1	48,0	44,56	43,42	-	30,5	20,5	28,0	7,5		
HD 30 - 5M 15	30	1	51,0	47,75	46,61	-	35,0	20,5	28,0	7,5		
HD 32 - 5M 15	32	1	54,0	50,93	49,79	-	38,0	20,5	28,0	7,5		
HD 36 - 5M 15	36	1	60,0	57,30	56,16	-	38,0	20,5	28,0	7,5		
HD 40 - 5M 15	40	1	71,0	63,66	62,52	-	38,0	20,5	28,0	7,5		
HD 44 - 5M 15	44	1A	-	70,03	68,89	-	38,0	20,5	30,0	9,5		
HD 48 - 5M 15	48	1A	-	76,39	75,25	-	45,0	20,5	30,0	9,5		
HD 60 - 5M 15	60	1A	-	95,49	94,35	-	50,0	20,5	30,0	9,5		
HD 72 - 5M 15	72	3A	-	114,59	113,45	90	50,0	20,5	30,0	9,5		

Dimensions des poulies dentées TOP DRIVE® HTD - moyeu plein



HD ... -5M25

5M

Code	Nb de dents	Type	E [mm]	R [mm]	S [mm]	U [mm]	H [mm]	W [mm]	Y [mm]	Z [mm]	Flasque	Matière
HD 12 - 5M 25	12	1	23,0	19,10	17,96	-	12,0	30,0	36,0	6,0	avec flasque	acier
HD 14 - 5M 25	14	1	25,0	22,28	21,14	-	13,0	30,0	36,0	6,0		
HD 15 - 5M 25	15	1	28,0	23,87	22,73	-	16,0	30,0	36,0	6,0		
HD 16 - 5M 25	16	1	28,0	25,47	24,32	-	16,5	30,0	36,0	6,0		
HD 18 - 5M 25	18	1	32,0	28,65	27,51	-	20,0	30,0	36,0	6,0		
HD 20 - 5M 25	20	1	36,0	31,83	30,69	-	23,0	30,0	36,0	6,0		
HD 21 - 5M 25	21	1	38,0	33,42	32,28	-	24,0	30,0	38,0	8,0		
HD 22 - 5M 25	22	1	39,0	35,01	33,87	-	25,5	30,0	38,0	8,0		
HD 24 - 5M 25	24	1	42,0	38,19	37,06	-	27,0	30,0	38,0	8,0		
HD 26 - 5M 25	26	1	44,0	41,38	40,24	-	30,0	30,0	38,0	8,0		
HD 28 - 5M 25	28	1	48,0	44,56	43,42	-	30,5	30,0	38,0	8,0		
HD 30 - 5M 25	30	1	51,0	47,75	46,61	-	35,0	30,0	38,0	8,0		
HD 32 - 5M 25	32	1	54,0	50,93	49,79	-	38,0	30,0	38,0	8,0		
HD 36 - 5M 25	36	1	60,0	57,30	56,16	-	38,0	30,0	38,0	8,0		
HD 40 - 5M 25	40	1	71,0	63,66	62,52	-	38,0	30,0	38,0	8,0		
HD 44 - 5M 25	44	1A - 3A	-	70,03	68,89	-	38,0	30,0	40,0	10,0		
HD 48 - 5M 25	48	1A - 3A	-	76,39	75,25	-	45,0	30,0	40,0	10,0		
HD 60 - 5M 25	60	1A - 3A	-	95,49	94,35	-	50,0	30,0	40,0	10,0		
HD 72 - 5M 25	72	3A	-	114,59	113,45	90	50,0	30,0	40,0	10,0		

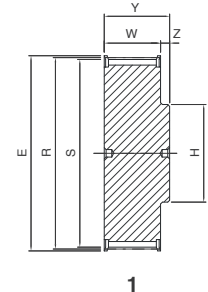

1

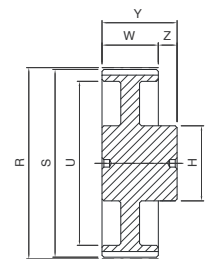

3A

HD ... -8M20

8M

Code	Nb de dents	Type	E [mm]	R [mm]	S [mm]	U [mm]	H [mm]	d [mm]	W [mm]	Y [mm]	Z [mm]	Flasque	Matière
HD 18 - 8M 20	18	1	51,0	45,84	44,46	-	32,0	-	28	38	10	avec flasque	acier
HD 20 - 8M 20	20	1	57,0	50,93	49,56	-	36,0	-	28	38	10		
HD 22 - 8M 20	22	1	60,0	56,02	54,65	-	43,0	-	28	38	10		
HD 24 - 8M 20	24	1	66,0	61,12	59,74	-	45,0	-	28	38	10		
HD 26 - 8M 20	26	1	70,0	66,21	64,84	-	48,0	-	28	38	10		
HD 28 - 8M 20	28	1	75,0	71,30	69,93	-	55,0	-	28	38	10		
HD 30 - 8M 20	30	1	83,0	76,39	75,02	-	60,0	-	28	38	10		
HD 32 - 8M 20	32	1	87,0	81,49	80,12	-	64,0	-	28	38	10		
HD 34 - 8M 20	34	1	91,0	86,58	85,21	-	70,0	-	28	38	10		
HD 36 - 8M 20	36	1	97,0	91,67	90,30	-	75,0	-	28	38	10		
HD 38 - 8M 20	38	1	102,0	96,77	95,39	-	80,0	-	28	38	10		
HD 40 - 8M 20	40	1	106,0	101,86	100,49	-	85,0	-	28	38	10		
HD 44 - 8M 20	44	1	120,0	112,05	110,67	-	96,0	-	28	38	10		
HD 48 - 8M 20	48	1	128,0	122,23	120,86	-	104,0	-	28	38	10		
HD 56 - 8M 20	56	5	150,0	142,60	141,23	117	80,0	12	28	38	10		
HD 60 - 8M 20	60	5	158,0	152,79	151,42	127	80,0	12	28	38	10		
HD 64 - 8M 20	64	5	168,0	162,97	161,60	137	80,0	12	28	38	10		
HD 72 - 8M 20	72	5	192,0	183,35	181,97	158	80,0	12	28	38	10		
HD 80 - 8M 20	80	5A	-	203,72	202,35	179	90,0	12	28	38	10		
HD 84 - 8M 20	84	5A	-	213,90	212,53	190	90,0	12	28	38	10		
HD 90 - 8M 20	90	5A	-	229,18	227,81	204	90,0	12	28	38	10		
HD 112 - 8M 20	112	5B	-	285,21	283,83	260	90,0	18	28	38	10		
HD 144 - 8M 20	144	5B	-	366,69	365,32	342	90,0	20	28	38	10		
HD 168 - 8M 20	168	5B	-	427,80	426,44	403	100,0	20	28	38	10		
HD 192 - 8M 20	192	5B	-	488,92	487,54	465	100,0	20	28	38	10		

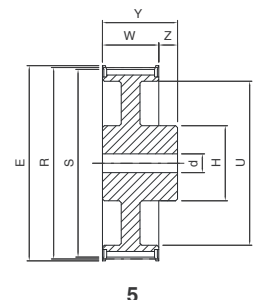

5

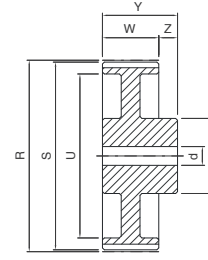

5A

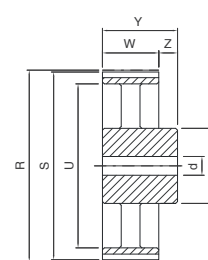

5B

Dimensions des poulies dentées TOP DRIVE® HTD - moyeu plein



HD ... -8M30

8M

Code	Nb de dents	Type	E [mm]	R [mm]	S [mm]	U [mm]	H [mm]	d [mm]	W [mm]	Y [mm]	Z [mm]	Flasque	Matière
HD 18 - 8M 30	18	1	51,0	45,84	44,46	-	32,0	-	38	48	10	avec flasque	acier
HD 20 - 8M 30	20	1	57,0	50,93	49,56	-	36,0	-	38	48	10		
HD 22 - 8M 30	22	1	60,0	56,02	54,65	-	43,0	-	38	48	10		
HD 24 - 8M 30	24	1	66,0	61,12	59,74	-	45,0	-	38	48	10		
HD 26 - 8M 30	26	1	70,0	66,21	64,84	-	48,0	-	38	48	10		
HD 28 - 8M 30	28	1	75,0	71,30	69,93	-	55,0	-	38	48	10		
HD 30 - 8M 30	30	1	83,0	76,39	75,02	-	60,0	-	38	48	10		
HD 32 - 8M 30	32	1	87,0	81,49	80,12	-	64,0	-	38	48	10		
HD 34 - 8M 30	34	1	91,0	86,58	85,21	-	70,0	-	38	48	10		
HD 36 - 8M 30	36	1	97,0	91,67	90,30	-	75,0	-	38	48	10		
HD 38 - 8M 30	38	1	102,0	96,77	95,39	-	75,0	-	38	48	10		
HD 40 - 8M 30	40	1	106,0	101,86	100,49	-	85,0	-	38	48	10		
HD 44 - 8M 30	44	1	120,0	112,05	110,67	-	96,0	-	38	48	10		
HD 48 - 8M 30	48	1	128,0	122,23	120,86	-	104,0	-	38	48	10		
HD 56 - 8M 30	56	5	150,0	142,60	141,23	117	90,0	12	38	48	10		
HD 60 - 8M 30	60	5	158,0	152,79	151,42	127	90,0	12	38	48	10		
HD 64 - 8M 30	64	5	168,0	162,97	161,60	137	90,0	12	38	48	10		
HD 72 - 8M 30	72	5	192,0	183,35	181,97	158	95,0	12	38	48	10		
HD 80 - 8M 30	80	5A	-	203,72	202,35	179	100,0	12	38	48	10		
HD 84 - 8M 30	84	5A	-	213,90	212,53	190	100,0	12	38	48	10		
HD 90 - 8M 30	90	5A	-	229,18	227,81	204	100,0	12	38	48	10		
HD 112 - 8M 30	112	5B	-	285,21	283,83	260	100,0	18	38	48	10		
HD 144 - 8M 30	144	5B	-	366,69	365,32	342	100,0	20	38	48	10		
HD 168 - 8M 30	168	5B	-	427,80	426,44	403	100,0	20	38	48	10		
HD 192 - 8M 30	192	5B	-	488,92	487,54	465	100,0	20	38	48	10		

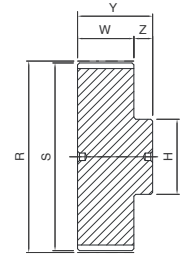

1A

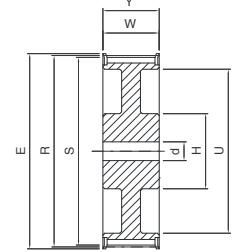

7

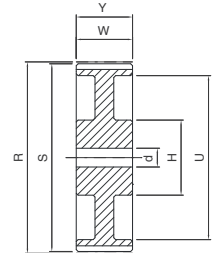

7A

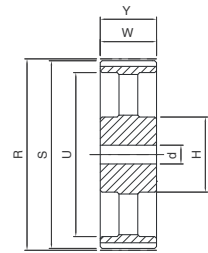

7B

HD ... -8M50

8M

Code	Nb de dents	Type	E [mm]	R [mm]	S [mm]	U [mm]	H [mm]	d [mm]	W [mm]	Y [mm]	Z [mm]	Flasque	Matière
HD 18 - 8M 50	18	1	51,0	45,84	44,46	-	32,0	-	60	70	10	avec flasque	acier
HD 20 - 8M 50	20	1	57,0	50,93	49,56	-	36,0	-	60	70	10		
HD 22 - 8M 50	22	1	60,0	56,02	54,65	-	43,0	-	60	70	10		
HD 24 - 8M 50	24	1	66,0	61,12	59,74	-	49,0	-	60	70	10		
HD 26 - 8M 50	26	1	70,0	66,21	64,84	-	50,0	-	60	70	10		
HD 28 - 8M 50	28	1	75,0	71,30	69,93	-	55,0	-	60	70	10		
HD 30 - 8M 50	30	1	83,0	76,39	75,02	-	60,0	-	60	70	10		
HD 32 - 8M 50	32	1	87,0	81,49	80,12	-	64,0	-	60	70	10		
HD 34 - 8M 50	34	1	91,0	86,58	85,21	-	70,0	-	60	70	10		
HD 36 - 8M 50	36	1	97,0	91,67	90,30	-	75,0	-	60	70	10		
HD 38 - 8M 50	38	1	102,0	96,77	95,39	-	80,0	-	60	70	10		
HD 40 - 8M 50	40	1	106,0	101,86	100,49	-	85,0	-	60	70	10		
HD 44 - 8M 50	44	1	120,0	112,05	110,67	-	96,0	-	60	70	10		
HD 48 - 8M 50	48	1	128,0	122,23	120,86	-	104,0	-	60	70	10		
HD 56 - 8M 50	56	7	150,0	142,60	141,23	117	90,0	18	60	60	-		
HD 60 - 8M 50	60	7	158,0	152,79	151,42	127	100,0	18	60	60	-		
HD 64 - 8M 50	64	7	168,0	162,97	161,60	137	100,0	18	60	60	-		
HD 72 - 8M 50	72	7	192,0	183,35	181,97	158	100,0	18	60	60	-		
HD 80 - 8M 50	80	7A	-	203,72	202,35	179	110,0	18	60	60	-		
HD 84 - 8M 50	84	7B	-	213,90	212,53	190	110,0	18	60	60	-		
HD 90 - 8M 50	90	7B	-	229,18	227,81	204	110,0	18	60	60	-		
HD 112 - 8M 50	112	7B	-	285,21	283,83	260	110,0	18	60	60	-		
HD 144 - 8M 50	144	7B	-	366,69	365,32	342	110,0	20	60	60	-		
HD 168 - 8M 50	168	7B	-	427,80	426,44	403	120,0	20	60	60	-		
HD 192 - 8M 50	192	7B	-	488,92	487,54	465	130,0	20	60	60	-		

Dimensions des poulies dentées TOP DRIVE® HTD - Moyeu plein



HD ... -8M85

8M

Code	Nb de dents	Type	E [mm]	R [mm]	S [mm]	U [mm]	H [mm]	d [mm]	W [mm]	Y [mm]	Z [mm]	Flasque	Matière
HD 22 - 8M 85	22	1	60,0	56,02	54,65	-	43,0	-	95	105	10	avec flasque	acier
HD 24 - 8M 85	24	1	66,0	61,12	59,74	-	45,0	-	95	105	10		
HD 26 - 8M 85	26	1	70,0	66,21	64,84	-	48,0	-	95	105	10		
HD 28 - 8M 85	28	1	75,0	71,30	69,93	-	55,0	-	95	105	10		
HD 30 - 8M 85	30	1	83,0	76,39	75,02	-	60,0	-	95	105	10		
HD 32 - 8M 85	32	1	87,0	81,49	80,12	-	64,0	-	95	105	10		
HD 34 - 8M 85	34	1	91,0	86,58	85,21	-	70,0	-	95	105	10		
HD 36 - 8M 85	36	1	97,0	91,67	90,30	-	75,0	-	95	105	10		
HD 38 - 8M 85	38	1	102,0	96,77	95,39	-	80,0	-	95	105	10		
HD 40 - 8M 85	40	1	106,0	101,86	100,49	-	85,0	-	95	105	10		
HD 44 - 8M 85	44	1	120,0	112,05	110,67	-	96,0	-	95	105	10		
HD 48 - 8M 85	48	1	128,0	122,23	120,86	-	100,0	-	95	105	10		
HD 56 - 8M 85	56	1	150,0	142,60	141,23	-	107,0	-	95	105	10		
HD 60 - 8M 85	60	1	158,0	152,79	151,42	-	132,0	-	95	105	10		
HD 64 - 8M 85	64	7	168,0	162,97	161,60	137	100,0	18	95	95	-		
HD 72 - 8M 85	72	7	192,0	183,35	181,97	158	110,0	18	95	95	-		
HD 80 - 8M 85	80	7A	-	203,72	202,35	179	110,0	20	95	95	-		
HD 84 - 8M 85	84	7B	-	213,90	212,53	190	110,0	20	95	95	-		
HD 90 - 8M 85	90	7B	-	229,18	227,81	204	110,0	20	95	95	-		
HD 112 - 8M 85	112	7B	-	285,21	283,83	260	110,0	24	95	95	-		
HD 144 - 8M 85	144	7B	-	366,69	365,32	342	120,0	24	95	95	-		
HD 168 - 8M 85	168	7B	-	427,80	426,44	403	120,0	24	95	95	-		
HD 192 - 8M 85	192	7B	-	488,92	487,54	465	130,0	24	95	95	-		

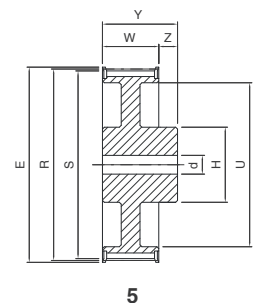
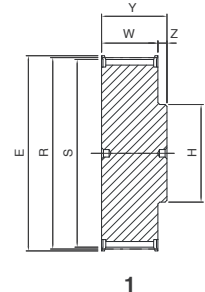

HD ... -14M40

14M

Code	Nb de dents	Type	E [mm]	R [mm]	S [mm]	U [mm]	H [mm]	d [mm]	W [mm]	Y [mm]	Z [mm]	Flasque	Matière
HD 28 - 14M 40	28	1	128,0	124,78	122,12	-	100,0	-	54	69	15	avec flasque	fonte
HD 29 - 14M 40	29	1	138,0	129,23	126,57	-	107,0	-	54	69	15		
HD 30 - 14M 40	30	1	138,0	133,69	130,99	-	107,0	-	54	69	15		
HD 32 - 14M 40	32	1	154,0	142,60	139,88	-	114,0	-	54	69	15		
HD 34 - 14M 40	34	1	160,0	151,51	148,79	-	122,0	-	54	69	15		
HD 36 - 14M 40	36	1	168,0	160,43	157,68	-	128,0	-	54	69	15		
HD 38 - 14M 40	38	1	183,0	169,34	166,60	-	141,0	-	54	69	15		
HD 40 - 14M 40	40	1	198,0	178,25	175,49	-	148,0	-	54	69	15		
HD 44 - 14M 40	44	5	211,0	196,08	193,28	154	120,0	24	54	69	15		
HD 48 - 14M 40	48	5	226,0	213,90	211,11	172	135,0	24	54	69	15		
HD 56 - 14M 40	56	5	256,0	249,55	246,76	207	135,0	28	54	69	15		
HD 60 - 14M 40	60	5	275,0	267,38	264,59	225	135,0	28	54	69	15		
HD 64 - 14M 40	64	5	296,0	285,21	282,41	243	135,0	28	54	69	15		
HD 72 - 14M 40	72	5B	-	320,86	318,06	279	135,0	28	54	69	15		
HD 80 - 14M 40	80	5B	-	356,51	353,71	314	135,0	28	54	69	15		
HD 84 - 14M 40	84	5B	-	374,33	371,54	332	135,0	28	54	69	15		
HD 90 - 14M 40	90	5B	-	401,07	398,28	359	135,0	28	54	69	15		
HD 112 - 14M 40	112	5B	-	499,11	496,32	457	135,0	28	54	69	15		
HD 144 - 14M 40	144	5B	-	641,71	638,92	600	135,0	28	54	69	15		

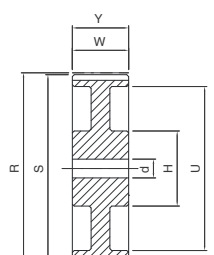
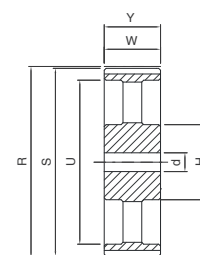
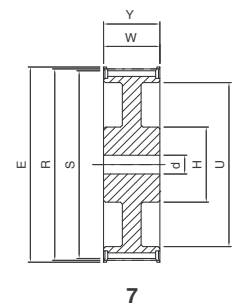
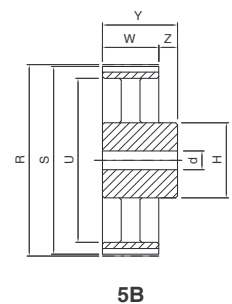

Dimensions des poulies dentées TOP DRIVE® HTD - moyeu plein



HD ... -14M55

14M

Code	Nb de dents	Type	E [mm]	R [mm]	S [mm]	U [mm]	H [mm]	d [mm]	W [mm]	Y [mm]	Z [mm]	Flasque	Matière
HD 28 - 14M 55	28	1	128,0	124,78	122,12	-	100,0	-	70	85	15	avec flasque	fonte
HD 29 - 14M 55	29	1	138,0	129,23	126,57	-	107,0	-	70	85	15		
HD 30 - 14M 55	30	1	138,0	133,69	130,99	-	107,0	-	70	85	15		
HD 32 - 14M 55	32	1	154,0	142,60	139,88	-	114,0	-	70	85	15		
HD 34 - 14M 55	34	1	160,0	151,51	148,79	-	122,0	-	70	85	15		
HD 36 - 14M 55	36	1	168,0	160,43	157,68	-	128,0	-	70	85	15		
HD 38 - 14M 55	38	1	183,0	169,34	166,60	-	141,0	-	70	85	15		
HD 40 - 14M 55	40	1	198,0	178,25	175,49	-	148,0	-	70	85	15		
HD 44 - 14M 55	44	5	211,0	196,08	193,28	154	120,0	24	70	85	15		
HD 48 - 14M 55	48	7	226,0	213,90	211,11	172	135,0	24	70	70	-		
HD 56 - 14M 55	56	7	256,0	249,55	246,76	207	135,0	28	70	70	-		
HD 60 - 14M 55	60	7	275,0	267,38	264,59	225	135,0	28	70	70	-		
HD 64 - 14M 55	64	7	296,0	285,21	282,41	243	135,0	28	70	70	-		
HD 72 - 14M 55	72	7B	-	320,86	318,06	279	135,0	28	70	70	-		
HD 80 - 14M 55	80	7B	-	356,51	353,71	314	135,0	28	70	70	-		
HD 84 - 14M 55	84	7B	-	374,33	371,54	332	135,0	28	70	70	-		
HD 90 - 14M 55	90	7B	-	401,07	398,28	359	135,0	28	70	70	-		
HD 112 - 14M 55	112	7B	-	499,11	496,32	457	135,0	28	70	70	-		
HD 144 - 14M 55	144	7B	-	641,71	638,92	600	135,0	28	70	70	-		

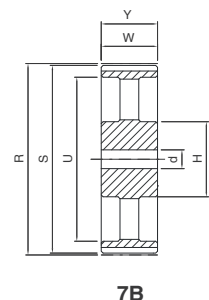
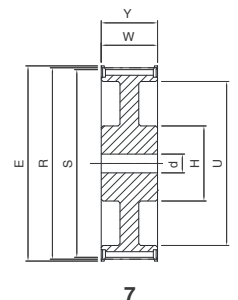
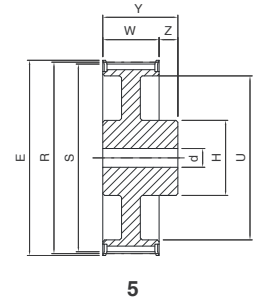
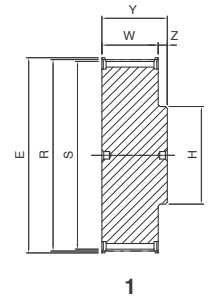

HD ... -14M85

14M

Code	Nb de dents	Type	E [mm]	R [mm]	S [mm]	U [mm]	H [mm]	d [mm]	W [mm]	Y [mm]	Z [mm]	Flasque	Matière
HD 28 - 14M 85	28	1	128,0	124,78	122,12	-	100,0	-	102	117	15	avec flasque	fonte
HD 29 - 14M 85	29	1	138,0	129,23	126,57	-	107,0	-	102	117	15		
HD 30 - 14M 85	30	1	138,0	133,69	130,99	-	107,0	-	102	117	15		
HD 32 - 14M 85	32	1	154,0	142,60	139,88	-	114,0	-	102	117	15		
HD 34 - 14M 85	34	1	160,0	151,51	148,79	-	122,0	-	102	117	15		
HD 36 - 14M 85	36	1	168,0	160,43	157,68	-	128,0	-	102	117	15		
HD 38 - 14M 85	38	1	183,0	169,34	166,60	-	141,0	-	102	117	15		
HD 40 - 14M 85	40	1	198,0	178,25	175,49	-	148,0	-	102	117	15		
HD 44 - 14M 85	44	1	211,0	196,08	193,28	-	169,0	-	102	117	15		
HD 48 - 14M 85	48	1	226,0	213,90	211,11	-	186,0	-	102	117	15		
HD 56 - 14M 85	56	7	256,0	249,55	246,76	207	150,0	32	102	102	-		
HD 60 - 14M 85	60	7	275,0	267,38	264,59	225	150,0	32	102	102	-		
HD 64 - 14M 85	64	7	296,0	285,21	282,41	243	150,0	32	102	102	-		
HD 72 - 14M 85	72	7B	-	320,86	318,06	279	150,0	32	102	102	-		
HD 80 - 14M 85	80	7B	-	356,51	353,71	314	150,0	32	102	102	-		
HD 84 - 14M 85	84	7B	-	374,33	371,54	332	150,0	32	102	102	-		
HD 90 - 14M 85	90	7B	-	401,07	398,28	359	150,0	32	102	102	-		
HD 112 - 14M 85	112	7B	-	499,11	496,32	457	150,0	32	102	102	-		
HD 144 - 14M 85	144	7B	-	641,71	638,92	600	150,0	32	102	102	-		

Dimensions des poulies dentées TOP DRIVE® HTD - moyeu plein



HD ... -14M115

14M

Code	Nb de dents	Type	E [mm]	R [mm]	S [mm]	U [mm]	H [mm]	d [mm]	W [mm]	Y [mm]	Z [mm]	Flasque	Matière
HD 28 - 14M 115	28	1	128,0	124,78	122,12	-	100,0	-	133	148	15	avec flasque	fonte
HD 29 - 14M 115	29	1	138,0	129,23	126,57	-	107,0	-	133	148	15		
HD 30 - 14M 115	30	1	138,0	133,69	130,99	-	107,0	-	133	148	15		
HD 32 - 14M 115	32	1	154,0	142,60	139,88	-	114,0	-	133	148	15		
HD 34 - 14M 115	34	1	160,0	151,51	148,79	-	122,0	-	133	148	15		
HD 36 - 14M 115	36	1	168,0	160,43	157,68	-	128,0	-	133	148	15		
HD 38 - 14M 115	38	1	183,0	169,34	166,60	-	141,0	-	133	148	15		
HD 40 - 14M 115	40	1	198,0	178,25	175,49	-	148,0	-	133	148	15		
HD 44 - 14M 115	44	1	211,0	196,08	193,28	-	169,0	-	133	148	15		
HD 48 - 14M 115	48	1	226,0	213,90	211,11	-	186,0	-	133	148	15		
HD 56 - 14M 115	56	5	256,0	249,55	246,76	207	150,0	32	133	148	15		
HD 60 - 14M 115	60	7	290,0	267,38	264,59	225	150,0	32	133	133	-		
HD 64 - 14M 115	64	7	296,0	285,21	282,41	243	150,0	32	133	133	-		
HD 72 - 14M 115	72	7B	-	320,86	318,06	279	150,0	32	133	133	-		
HD 80 - 14M 115	80	7B	-	356,51	353,71	314	150,0	32	133	133	-		
HD 84 - 14M 115	84	7B	-	374,33	371,54	332	150,0	32	133	133	-		
HD 90 - 14M 115	90	7B	-	401,07	398,28	359	150,0	32	133	133	-		
HD 112 - 14M 115	112	7B	-	499,11	496,32	457	150,0	32	133	133	-		
HD 144 - 14M 115	144	7B	-	641,71	638,92	600	150,0	32	133	133	-		

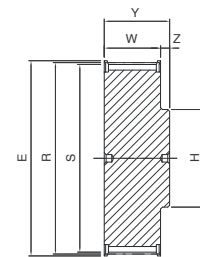

1

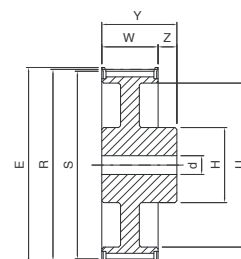

5

HD ... -14M170

14M

Code	Nb de dents	Type	E [mm]	R [mm]	S [mm]	U [mm]	H [mm]	d [mm]	W [mm]	Y [mm]	Z [mm]	Flasque	Matière
HD 28 - 14M 170	28	1	128,0	124,78	122,12	-	100,0	-	187	202	15	avec flasque	fonte
HD 29 - 14M 170	29	1	138,0	129,23	126,57	-	107,0	-	187	202	15		
HD 30 - 14M 170	30	1	138,0	133,69	130,99	-	107,0	-	187	202	15		
HD 32 - 14M 170	32	1	154,0	142,60	139,88	-	114,0	-	187	202	15		
HD 34 - 14M 170	34	1	160,0	151,51	148,79	-	122,0	-	187	202	15		
HD 36 - 14M 170	36	1	168,0	160,43	157,68	-	128,0	-	187	202	15		
HD 38 - 14M 170	38	1	183,0	169,34	166,60	-	141,0	-	187	202	15		
HD 40 - 14M 170	40	1	198,0	178,25	175,49	-	148,0	-	187	202	15		
HD 44 - 14M 170	44	1	211,0	196,08	193,28	-	169,0	-	187	202	15		
HD 48 - 14M 170	48	1	226,0	213,90	211,11	-	186,0	-	187	202	15		
HD 56 - 14M 170	56	5	256,0	249,55	246,76	207	160,0	32	187	202	15		
HD 60 - 14M 170	60	5	290,0	267,38	264,59	225	160,0	32	187	202	15		
HD 64 - 14M 170	64	5	296,0	285,21	282,41	243	180,0	32	187	202	15		
HD 72 - 14M 170	72	12	-	320,86	318,06	279	180,0	32	187	187	-		
HD 80 - 14M 170	80	12	-	356,51	353,71	314	180,0	32	187	187	-		
HD 84 - 14M 170	84	7A	-	374,33	371,54	332	180,0	32	187	187	-		
HD 90 - 14M 170	90	7A	-	401,07	398,28	359	180,0	32	187	187	-		
HD 112 - 14M 170	112	7A	-	499,11	496,32	456	200,0	32	187	187	-		
HD 144 - 14M 170	144	7A	-	641,71	638,92	600	220,0	32	187	187	-		

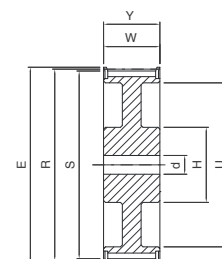

7

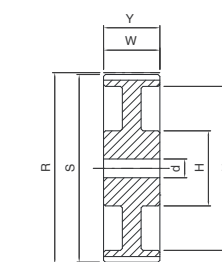

7A

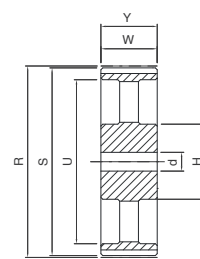

7B

Dimensions des poulies dentées TOP DRIVE® HTD - moyeu amovible SER-SIT® Types 5M - 8M - 14M



Désignation	HDB 32 - 8M 20
Poulies HTD - moyeu amovible	
Nombre de dents	
Pas	
Largeur de la courroie en mm	

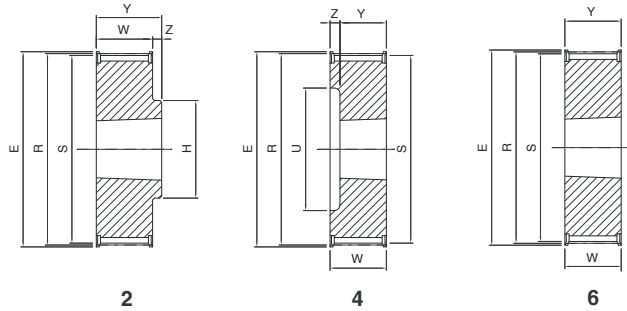

HDB ... -5M15

Code	Nb de dents	Type	Moyeu amovible SER-SIT®	E [mm]	R [mm]	S [mm]	U [mm]	H [mm]	W [mm]	Y [mm]	Z [mm]	Flasque	Matière
HDB 34 - 5M 15	34	6	1008	57,0	54,11	52,97	-	-	22	22	-	avec flasque	acier
HDB 36 - 5M 15	36	6	1108	60,0	57,3	56,16	-	-	22	22	-		
HDB 38 - 5M 15	38	6	1108	66,5	60,48	59,34	-	-	22	22	-		
HDB 40 - 5M 15	40	6	1108	71,0	63,66	62,52	-	-	22	22	-		
HDB 44 - 5M 15	44	6	1108	75,0	70,03	68,89	-	-	22	22	-		
HDB 48 - 5M 15	48	2	1210	83,0	76,39	75,25	-	62,0	20,5	25	4,5		
HDB 56 - 5M 15	56	2	1210	93,0	89,13	87,99	-	70,0	20,5	25	4,5		
HDB 64 - 5M 15	64	2	1210	106,0	101,86	100,72	-	80,0	20,5	25	4,5		
HDB 72 - 5M 15	72	2	1610	119,0	114,59	113,45	-	92,0	20,5	25	4,5		
HDB 80 - 5M 15	80	2	1610	135,0	127,32	126,18	-	92,0	20,5	25	4,5		
HDB 90 - 5M 15	90	11A	1610	-	143,24	142,10	122	92,0	20,5	25	4,5		
HDB 112 - 5M 15	112	11A	1610	-	178,25	177,11	157	110,0	20,5	25	4,5		
HDB 136 - 5M 15	136	11A	2012	-	216,45	215,31	195	110,0	20,5	32	5,8		
HDB 150 - 5M 15	150	11A	2012	-	238,73	237,59	217	110,0	20,5	32	5,8		

5M

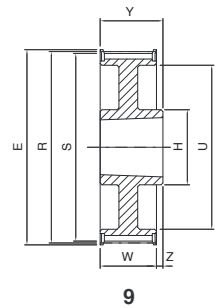

9

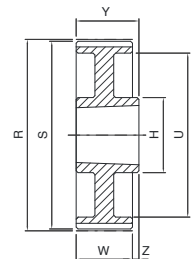

9A

HDB ... -8M20

Code	Nb de dents	Type	Moyeu amovible SER-SIT®	E [mm]	R [mm]	S [mm]	U [mm]	H [mm]	W [mm]	Y [mm]	Z [mm]	Flasque	Matière
HDB 22 - 8M 20	22	4	1008	60,0	56,02	54,65	38	-	28	22	6	avec flasque	fonte
HDB 24 - 8M 20	24	4	1108	66,0	61,12	59,74	42	-	28	22	6		
HDB 26 - 8M 20	26	4	1108	70,0	66,21	64,84	45	-	28	22	6		
HDB 28 - 8M 20	28	4	1108	75,0	71,30	70,08	52	-	28	22	6		
HDB 30 - 8M 20	30	4	1108	83,0	76,39	75,13	56	-	28	22	6		
HDB 32 - 8M 20	32	4	1610	87,0	81,49	80,16	65	-	28	25	3		
HDB 34 - 8M 20	34	4	1610	91,0	86,58	85,21	66	-	28	25	3		
HDB 36 - 8M 20	36	4	1610	97,0	91,67	90,30	68	-	28	25	3		
HDB 38 - 8M 20	38	4	1610	102,0	96,77	95,39	76	-	28	25	3		
HDB 40 - 8M 20	40	4	1610	106,0	101,86	100,49	80	-	28	25	3		
HDB 44 - 8M 20	44	2	2012	120,0	112,05	110,67	-	93,0	28	32	4		
HDB 48 - 8M 20	48	2	2012	128,0	122,23	120,86	-	100,0	28	32	4		
HDB 56 - 8M 20	56	2	2012	150,0	142,60	141,23	-	110,0	28	32	4		
HDB 64 - 8M 20	64	9	2012	168,0	162,97	161,60	140	110,0	28	32	4		
HDB 72 - 8M 20	72	9	2012	192,0	183,35	181,97	158	110,0	28	32	4		
HDB 80 - 8M 20	80	9A	2012	-	203,74	202,35	178	110,0	28	32	4		
HDB 90 - 8M 20	90	9B	2012	-	229,18	227,81	204	110,0	28	32	4		

8M

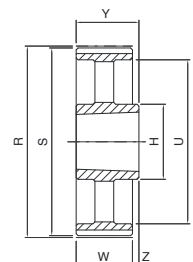

9B

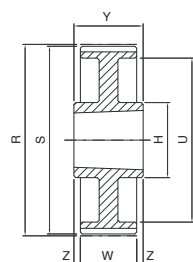

11A

Dimensions des poulies dentées TOP DRIVE® HTD - moyeu amovible SER-SIT®



HDB ... -8M30

8M

Code	Nb de dents	Type	Moyeu amovible SER-SIT®	E [mm]	R [mm]	S [mm]	U [mm]	H [mm]	W [mm]	Y [mm]	Z [mm]	Flasque	Matière
HDB 22 - 8M 30	22	4	1008	60,0	56,02	54,65	38	-	38	22	16	avec flasque	fonte
HDB 24 - 8M 30	24	4	1108	66,0	61,12	59,74	42	-	38	22	16		
HDB 26 - 8M 30	26	4	1108	70,0	66,21	64,84	45	-	38	22	16		
HDB 28 - 8M 30	28	4	1108	75,0	71,30	70,08	52	-	38	22	16		
HDB 30 - 8M 30	30	6	1615	83,0	76,39	75,13	-	-	38	38	-		
HDB 32 - 8M 30	32	6	1615	87,0	81,49	80,16	-	-	38	38	-		
HDB 34 - 8M 30	34	6	1615	91,0	86,58	85,21	-	-	38	38	-		
HDB 36 - 8M 30	36	6	1615	97,0	91,67	90,30	-	-	38	38	-		
HDB 38 - 8M 30	38	6	1615	102,0	96,77	95,39	-	-	38	38	-		
HDB 40 - 8M 30	40	6	1615	106,0	101,86	100,49	-	-	38	38	-		
HDB 44 - 8M 30	44	5	2012	120,0	112,05	110,67	90	-	38	32	3		
HDB 48 - 8M 30	48	5	2012	128,0	122,23	120,86	100	-	38	32	3		
HDB 56 - 8M 30	56	5	2012	150,0	142,60	141,23	118	-	38	32	3		
HDB 64 - 8M 30	64	9	2517	168,0	162,97	161,60	140	125,0	38	45	7		
HDB 72 - 8M 30	72	9	2517	192,0	183,35	181,97	158	125,0	38	45	7		
HDB 80 - 8M 30	80	9A	2517	-	203,74	202,35	178	125,0	38	45	7		
HDB 90 - 8M 30	90	9B	2517	-	229,18	227,81	204	125,0	38	45	7		
HDB 112 - 8M 30	112	9B	2517	-	285,21	283,83	260	125,0	38	45	7		
HDB 144 - 8M 30	144	9B	2517	-	366,69	365,32	341	125,0	38	45	7		

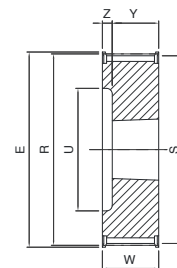

4

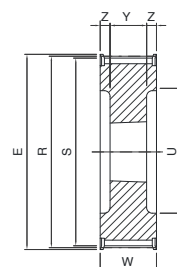

5

HDB ... -8M50

8M

Code	Nb de dents	Type	Moyeu amovible SER-SIT®	E [mm]	R [mm]	S [mm]	U [mm]	H [mm]	W [mm]	Y [mm]	Z [mm]	Flasque	Matière
HDB 28 - 8M 50	28	5	1108	75,0	71,30	70,08	52	-	60	22	19,0	avec flasque	fonte/acier
HDB 30 - 8M 50	30	4	1615	83,0	76,39	75,13	58	-	60	38	22,0		
HDB 32 - 8M 50	32	4	1615	87,0	81,49	80,16	60	-	60	38	22,0		
HDB 34 - 8M 50	34	4	1615	91,0	86,58	85,21	66	-	60	38	22,0		
HDB 36 - 8M 50	36	4	1615	97,0	91,67	90,30	68	-	60	38	22,0		
HDB 38 - 8M 50	38	4	1615	102,0	96,77	95,39	75	-	60	38	22,0		
HDB 40 - 8M 50	40	5	2012	106,0	101,86	100,49	80	-	60	32	14,0		
HDB 44 - 8M 50	44	5	2012	120,0	112,05	110,67	90	-	60	32	14,0		
HDB 48 - 8M 50	48	5	2012	128,0	122,23	120,86	100	-	60	32	14,0		
HDB 56 - 8M 50	56	5	2517	150,0	142,60	141,23	120	-	60	45	7,5		
HDB 64 - 8M 50	64	8	2517	168,0	162,97	161,60	138	120,0	60	45	7,5		
HDB 72 - 8M 50	72	8	2517	192,0	183,35	181,97	158	125,0	60	45	7,5		
HDB 80 - 8M 50	80	8A	3020	-	203,74	202,35	178	160,0	60	51	4,5		
HDB 90 - 8M 50	90	8A	3020	-	229,18	227,81	204	170,0	60	51	4,5		
HDB 112 - 8M 50	112	8B	3020	-	285,21	283,83	260	170,0	60	51	4,5		
HDB 144 - 8M 50	144	8B	3020	-	366,69	365,32	341	170,0	60	51	4,5		
HDB 168 - 8M 50	168	8B	3020	-	427,80	426,42	402	198,0	60	51	4,5		
HDB 192 - 8M 50	192	8B	3020	-	488,92	487,54	462	198,0	60	51	4,5		

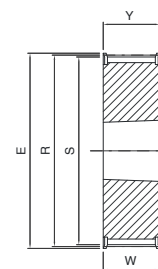

6

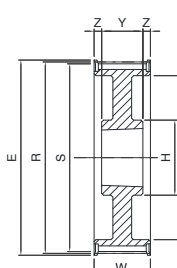

8

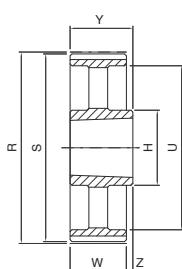

9B

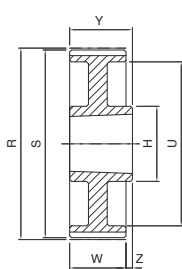

9A

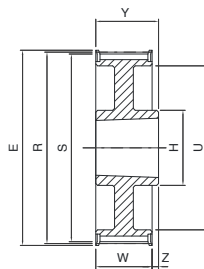

9

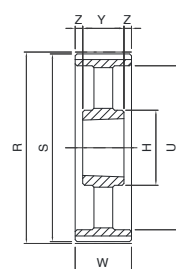

8B

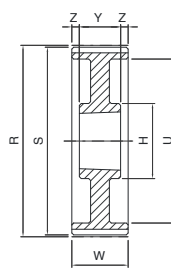

8A

Dimensions des poulies dentées TOP DRIVE® HTD - moyeu amovible SER-SIT®



HDB ... -8M85

8M

Code	Nb de dents	Type	Moyeu amovible SER-SIT®	E [mm]	R [mm]	S [mm]	U [mm]	H [mm]	W [mm]	Y [mm]	Z [mm]	Flasque	Matière
HDB 34 - 8M 85	34	5	1615	91,0	86,58	85,21	66	-	95	38	28,5	avec flasque	fonte
HDB 36 - 8M 85	36	5	1615	97,0	91,67	90,30	68	-	95	38	28,5		
HDB 38 - 8M 85	38	5	1615	102,0	96,77	95,39	75	-	95	38	28,5		
HDB 40 - 8M 85	40	5	2012	106,0	101,86	100,49	80	-	95	32	31,5		
HDB 44 - 8M 85	44	5	2012	120,0	112,05	110,67	90	-	95	32	31,5		
HDB 48 - 8M 85	48	5	2517	128,0	122,23	120,86	100	-	95	45	25,0		
HDB 56 - 8M 85	56	5	2517	150,0	142,60	141,23	120	-	95	45	25,0		
HDB 64 - 8M 85	64	5	2517	168,0	162,97	161,60	138	-	95	45	25,0		
HDB 72 - 8M 85	72	5	3020	192,0	183,35	181,97	158	-	95	51	22,0		
HDB 80 - 8M 85	80	8A	3020	-	203,74	202,35	178	160,0	95	51	22,0		
HDB 90 - 8M 85	90	8A	3020	-	229,18	227,81	204	170,0	95	51	22,0		
HDB 112 - 8M 85	112	8B	3020	-	285,21	283,83	260	170,0	95	51	22,0		
HDB 144 - 8M 85	144	8B	3030	-	366,69	365,32	341	198,0	95	76	9,5	sans flasque	fonte
HDB 168 - 8M 85	168	8B	3030	-	427,80	426,42	402	198,0	95	76	9,5		
HDB 192 - 8M 85	192	8B	3030	-	488,92	487,54	462	198,0	95	76	9,5		

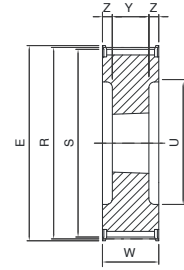

5

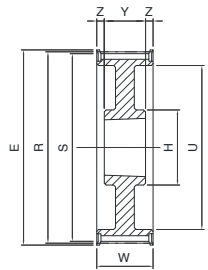

8

HDB ... -14M40

14M

Code	Nb de dents	Type	Moyeu amovible SER-SIT®	E [mm]	R [mm]	S [mm]	U [mm]	H [mm]	W [mm]	Y [mm]	Z [mm]	Flasque	Matière
HDB 28 - 14M 40	28	5	2012	128,0	124,78	122,12	98	-	54	32	11,0	avec flasque	fonte
HDB 29 - 14M 40	29	5	2012	138,0	129,23	126,57	100	-	54	32	11,0		
HDB 30 - 14M 40	30	5	2012	138,0	133,69	130,99	100	-	54	32	11,0		
HDB 32 - 14M 40	32	5	2012	154,0	142,60	139,88	104	-	54	32	11,0		
HDB 34 - 14M 40	34	5	2517	160,0	151,52	148,79	110	-	54	45	4,5		
HDB 36 - 14M 40	36	5	2517	168,0	160,43	157,68	120	-	54	45	4,5		
HDB 38 - 14M 40	38	5	2517	183,0	169,34	166,60	130	-	54	45	4,5		
HDB 40 - 14M 40	40	5	2517	188,0	178,25	175,49	138	-	54	45	4,5		
HDB 44 - 14M 40	44	5	3020	211,0	196,08	193,28	154	-	54	51	1,5		
HDB 48 - 14M 40	48	5	3020	226,0	213,90	211,11	172	-	54	51	1,5		
HDB 56 - 14M 40	56	8	3020	256,0	249,56	246,76	207	170,0	54	51	1,5	sans flasque	fonte
HDB 64 - 14M 40	64	8	3020	296,0	285,21	282,41	243	170,0	54	51	1,5		
HDB 72 - 14M 40	72	8A	3020	-	320,86	318,06	279	170,0	54	51	1,5		
HDB 80 - 14M 40	80	8B	3020	-	356,51	353,71	315	170,0	54	51	1,5		
HDB 90 - 14M 40	90	8B	3020	-	401,07	398,28	359	170,0	54	51	1,5		
HDB 112 - 14M 40	112	8B	3020	-	499,11	496,32	457	170,0	54	51	1,5		
HDB 144 - 14M 40	144	8B	3020	-	641,71	638,92	600	170,0	54	51	1,5		
HDB 168 - 14M 40	168	8B	3020	-	748,66	745,87	705	170,0	54	51	1,5		
HDB 192 - 14M 40	192	9B	3535	-	855,62	852,82	812	170,0	54	89	35		
HDB 216 - 14M 40	216	9B	3535	-	962,57	959,77	920	170,0	54	89	35		
HDB 264 - 14M 40	264	9B	3535	-	1176,47	1173,67	1133	170,0	54	89	35		

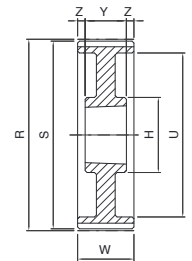

8A

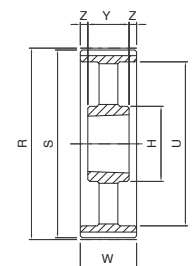

8B

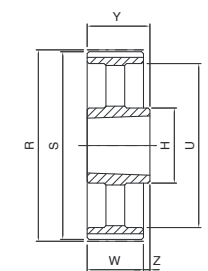

9B

Dimensions des poulies dentées TOP DRIVE® HTD - moyeu amovible SER-SIT®



HDB ... -14M55

14M

Code	Nb de dents	Type	Moyeu amovible SER-SIT®	E [mm]	R [mm]	S [mm]	U [mm]	H [mm]	W [mm]	Y [mm]	Z [mm]	Flasque	Matière
HDB 28 - 14M 55	28	5	2012	128,0	124,78	122,12	98	-	70	32	19,0	avec flasque	fonte
HDB 29 - 14M 55	29	5	2012	138,0	129,23	126,57	100	-	70	32	19,0		
HDB 30 - 14M 55	30	5	2517	138,0	133,69	130,99	100	-	70	45	12,5		
HDB 32 - 14M 55	32	5	2517	154,0	142,60	139,88	104	-	70	45	12,5		
HDB 34 - 14M 55	34	5	2517	160,0	151,52	148,79	110	-	70	45	12,5		
HDB 36 - 14M 55	36	5	2517	168,0	160,43	157,68	120	-	70	45	12,5		
HDB 38 - 14M 55	38	5	2517	183,0	169,34	166,60	130	-	70	45	12,5		
HDB 40 - 14M 55	40	5	2517	188,0	178,25	175,49	138	-	70	45	12,5		
HDB 44 - 14M 55	44	5	3020	211,0	196,08	193,28	154	-	70	51	9,5		
HDB 48 - 14M 55	48	5	3020	226,0	213,90	211,11	172	-	70	51	9,5		
HDB 56 - 14M 55	56	8	3020	256,0	249,56	246,76	207	170,0	70	51	9,5		
HDB 64 - 14M 55	64	8	3020	296,0	285,21	282,41	243	170,0	70	51	9,5		
HDB 72 - 14M 55	72	8A	3020	-	320,86	318,06	279	170,0	70	51	9,5		
HDB 80 - 14M 55	80	8B	3020	-	356,51	353,71	314	170,0	70	51	9,5		
HDB 90 - 14M 55	90	8B	3020	-	401,07	398,28	359	170,0	70	51	9,5		
HDB 112 - 14M 55	112	8B	3020	-	499,11	496,32	457	170,0	70	51	9,5		
HDB 144 - 14M 55	144	8B	3020	-	641,71	638,92	600	170,0	70	51	9,5		
HDB 168 - 14M 55	168	8B	3020	-	748,66	745,87	705	170,0	70	51	9,5		
HDB 192 - 14M 55	192	9B	3535	-	855,62	852,82	812	170,0	70	89	19,0		
HDB 216 - 14M 55	216	9B	3535	-	962,57	959,77	920	190,0	70	89	19,0		
HDB 264 - 14M 55	264	9B	3535	-	1176,47	1173,67	1133	190,0	70	89	19,0		

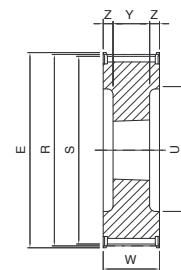

5

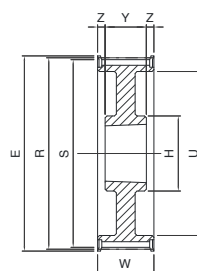

8

HDB ... -14M85

14M

Code	Nb de dents	Type	Moyeu amovible SER-SIT®	E [mm]	R [mm]	S [mm]	U [mm]	H [mm]	W [mm]	Y [mm]	Z [mm]	Flasque	Matière
HDB 28 - 14M 85	28	5	2517	128,0	124,78	122,12	98	-	102	45	28,5	avec flasque	fonte
HDB 29 - 14M 85	29	5	2517	138,0	129,23	126,57	100	-	102	45	28,5		
HDB 30 - 14M 85	30	5	2517	138,0	133,69	130,99	100	-	102	45	28,5		
HDB 32 - 14M 85	32	5	2517	154,0	142,60	139,88	104	-	102	45	28,5		
HDB 34 - 14M 85	34	5	2517	160,0	151,52	148,79	110	-	102	45	28,5		
HDB 36 - 14M 85	36	5	3020	168,0	160,43	157,68	120	-	102	51	25,5		
HDB 38 - 14M 85	38	5	3020	183,0	169,34	166,60	130	-	102	51	25,5		
HDB 40 - 14M 85	40	5	3020	188,0	178,25	175,49	138	-	102	51	25,5		
HDB 44 - 14M 85	44	5	3030	211,0	196,08	193,28	154	-	102	76	13,0		
HDB 48 - 14M 85	48	5	3030	226,0	213,90	211,11	172	-	102	76	13,0		
HDB 56 - 14M 85	56	5	3535	256,0	249,56	246,76	207	-	102	89	6,5		
HDB 64 - 14M 85	64	8	3535	296,0	285,21	282,41	243	178,0	102	89	6,5		
HDB 72 - 14M 85	72	8B	3535	-	320,86	318,06	279	178,0	102	89	6,5		
HDB 80 - 14M 85	80	8B	3535	-	356,51	353,71	314	190,0	102	89	6,5		
HDB 90 - 14M 85	90	8B	3535	-	401,07	398,28	359	190,0	102	89	6,5		
HDB 112 - 14M 85	112	8B	3535	-	499,11	496,32	457	190,0	102	89	6,5		
HDB 144 - 14M 85	144	8B	3535	-	641,71	638,92	600	190,0	102	89	6,5		
HDB 168 - 14M 85	168	8B	3535	-	748,66	745,87	705	190,0	102	89	6,5		
HDB 192 - 14M 85	192	8B	4040	-	855,62	852,82	812	190,0	102	102	-		
HDB 216 - 14M 85	216	8B	4040	-	962,57	959,77	920	190,0	102	102	-		
HDB 264 - 14M 85	264	8B	4040	-	1176,47	1173,67	1133	190,0	102	102	-		

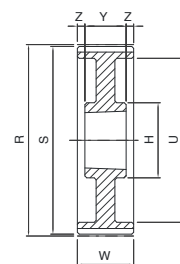

8A

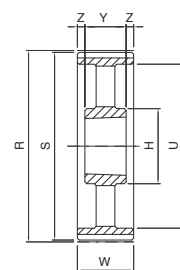

8B

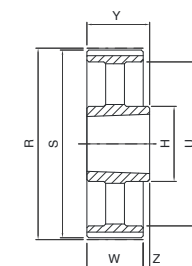

9B

Dimensions des poulies dentées TOP DRIVE® HTD - moyeu amovible SER-SIT®



HDB ... -14M115

14M

Code	Nb de dents	Type	Moyeu amovible SER-SIT®	E [mm]	R [mm]	S [mm]	U [mm]	H [mm]	W [mm]	Y [mm]	Z [mm]	Flasque	Matière
HDB 28 - 14M 115	28	5	2517	128,0	124,78	122,12	98	-	133	45	44,0	avec flasque	fonte
HDB 29 - 14M 115	29	5	2517	138,0	129,23	126,57	100	-	133	45	44,0		
HDB 30 - 14M 115	30	5	2517	138,0	133,69	130,99	100	-	133	45	44,0		
HDB 32 - 14M 115	32	5	2517	154,0	142,60	139,88	104	-	133	45	44,0		
HDB 34 - 14M 115	34	5	2517	160,0	151,52	148,79	110	-	133	45	44,0		
HDB 36 - 14M 115	36	5	3020	168,0	160,43	157,68	120	-	133	51	41,0		
HDB 38 - 14M 115	38	5	3020	183,0	169,34	166,60	130	-	133	51	41,0		
HDB 40 - 14M 115	40	5	3020	188,0	178,25	175,49	138	-	133	51	41,0		
HDB 44 - 14M 115	44	5	3030	211,0	196,08	193,28	154	-	133	76	28,5		
HDB 48 - 14M 115	48	5	3030	226,0	213,90	211,11	172	-	133	76	28,5		
HDB 56 - 14M 115	56	5	3535	256,0	249,56	246,76	207	-	133	89	22,0		
HDB 64 - 14M 115	64	8	3535	296,0	285,21	282,41	243	190,0	133	89	22,0		
HDB 72 - 14M 115	72	8A	3535	-	320,86	318,06	279	190,0	133	89	22,0		
HDB 80 - 14M 115	80	8B	3535	-	356,51	353,71	314	190,0	133	89	22,0		
HDB 90 - 14M 115	90	8B	3535	-	401,07	398,28	359	190,0	133	89	22,0		
HDB 112 - 14M 115	112	8B	3535	-	499,11	496,32	457	190,0	133	89	22,0		
HDB 144 - 14M 115	144	8B	4040	-	641,71	638,92	600	230,0	133	102	15,5		
HDB 168 - 14M 115	168	8B	4040	-	748,66	745,87	705	230,0	133	102	15,5		
HDB 192 - 14M 115	192	8B	4040	-	855,62	852,82	812	230,0	133	102	15,5		
HDB 216 - 14M 115	216	8B	4040	-	962,57	959,77	920	230,0	133	102	15,5		
HDB 264 - 14M 115	264	8B	5050	-	1176,47	1173,67	1133	230,0	133	127	3,0		

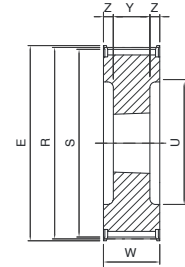

5

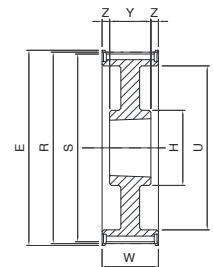

8

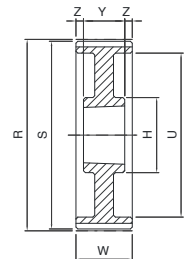

8A

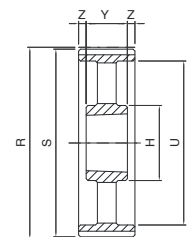

8B

HDB ... -14M170

14M

Code	Nb de dents	Type	Moyeu amovible SER-SIT®	E [mm]	R [mm]	S [mm]	U [mm]	H [mm]	W [mm]	Y [mm]	Z [mm]	Flasque	Matière
HDB 38 - 14M 170	38	5	3030	183,0	169,34	166,60	130	-	187	76	55,5	avec flasque	fonte
HDB 40 - 14M 170	40	5	3030	188,0	178,25	175,49	138	-	187	76	55,5		
HDB 44 - 14M 170	44	5	3535	211,0	196,08	193,28	154	-	187	89	49,0		
HDB 48 - 14M 170	48	5	3535	226,0	213,90	211,11	172	-	187	89	49,0		
HDB 56 - 14M 170	56	5	3535	256,0	249,56	246,76	207	-	187	89	49,0		
HDB 64 - 14M 170	64	5	4040	296,0	285,21	282,41	243	-	187	102	42,5		
HDB 72 - 14M 170	72	8A	4040	-	320,86	318,06	280	230,0	187	102	42,5		
HDB 80 - 14M 170	80	8A	4040	-	356,51	353,71	314	230,0	187	102	42,5		
HDB 90 - 14M 170	90	8B	4040	-	401,07	398,28	359	230,0	187	102	42,5		
HDB 112 - 14M 170	112	8B	5050	-	499,11	496,32	457	265,0	187	127	30,0		
HDB 144 - 14M 170	144	8B	5050	-	641,71	638,92	600	265,0	187	127	30,0		
HDB 168 - 14M 170	168	8B	5050	-	748,66	745,87	705	265,0	187	127	30,0		
HDB 192 - 14M 170	192	8B	5050	-	855,62	852,82	812	265,0	187	127	30,0		
HDB 216 - 14M 170	216	8B	5050	-	962,57	959,77	920	265,0	187	127	30,0		
HDB 264 - 14M 170	264	8B	5050	-	1176,47	1173,67	1133	265,0	187	127	30,0		

Les poulies STPD ont une conception différente des poulies dentées traditionnelles.

Le fond des rainures de la poulie est convexe et la profondeur des rainures est inférieure à la hauteur de la dent de la courroie, ce qui réduit considérablement l'effet polygonal.

La denture des poulies est prévue pour un engrenement pratiquement sans friction avec la courroie.

Les poulies STPD sont disponibles en moyeu plein et pour les assemblages avec moyeux amovible SER-SIT®.

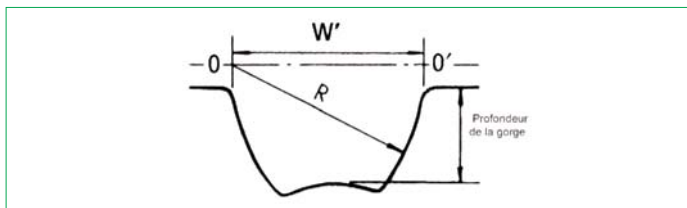

Moyeu plein

Matière : fonte / acier

Finition : phosphatation au manganèse noir.

Pas :

- S3M
- S4,5M
- S5M
- S8M
- S14M

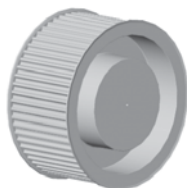

Pour le montage avec moyeux amovibles SER-SIT®

Matière : fonte.

Finition : phosphatation au manganèse noir.

Pas :

- S8M
- S14M

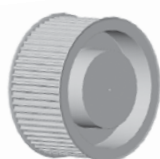

Exécutions spéciales

Sur demande, SIT est capable de concevoir et fabriquer tout type de poulie selon les exigences du client. Pour une vitesse périphérique supérieure à 33 m / s, il est fortement recommandé d'utiliser l'acier comme matériau de construction.

$$\text{Vitesse périphérique [m/s]} = \frac{\text{diamètre de la poulie [mm]} \times \text{tr/mn}}{19100}$$

Afin de réduire le poids, les poulies peuvent être fabriquées à partir d'alliages. Dans ce cas, leur durée de vie sera réduite, car le revêtement de courroies en nylon a un effet légèrement abrasif. Cet inconvénient peut être évité par un chromage de la denture de la poulie.

TOLÉRANCES

Tolérances du diamètre de la poulie

Diamètre externe [mm]	Tolérances [mm]
jusqu'à 25,4	-0,00 +0,05
de 25,5 à 50,8	-0,00 +0,08
de 50,9 à 101,6	-0,00 +0,10
de 101,7 à 177,8	-0,00 +0,13
de 177,9 à 304,8	-0,00 +0,15
de 304,9 à 508,0	-0,00 +0,18
plus de 508,1	-0,00 +0,25

Tolérance d'excentration maxi entre l'alésage et le diamètre extérieur

Diamètre externe [mm]	Excentricité totale mesurée [mm]
jusqu'à 200	0,13
plus de 200	ajoutez 0,0005 pour tout diamètre supérieur à 200 mm

Oscillation latérale ou voilage

Largeur de la poulie	Tolérance
par 100 mm	0,1 mm sans dépasser la tolérance de diamètre extérieur

Flasques

Les courroies dentées, lorsqu'elles sont en mouvement, se déplacent légèrement latéralement. Il est donc nécessaire d'utiliser au moins une poulie à flasques pour empêcher la courroie de sortir de la poulie.

Habituellement, afin de réduire les coûts, la poulie à flasques est celle de plus petit diamètre.

Cependant, lorsque la distance des axes est supérieure à 8 fois le diamètre de la petite poulie, ou lorsque la transmission s'effectue par des arbres disposés non horizontalement, les deux poulies doivent avoir des flasques.

Revêtement de protection

Toutes les poulies (acier et fonte) sont traitées avec un procédé de phosphatation au manganèse noir qui donne une plus grande résistance contre les agents oxydants. Ce traitement ne modifie pas le profil ou les dimensions des poulies.

Sur demande, SIT peut fournir une large gamme de revêtements spéciaux, liés aux besoins ou à des conditions environnementales critiques.

Note

En raison de l'amélioration constante de nos produits, les données techniques des poulies peuvent faire l'objet de modifications.

Dimensions des poulies dentées SUPER TORQUE - Moyeu plein

Types 8M - 14M

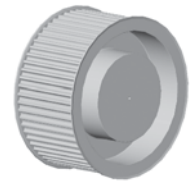

Désignation	ST 48 S 8M 20
Poulies dentées SUPERTORQUE - Moyeu plein	
Nombre de dents	
Pas	
Largeur de la courroie en mm	

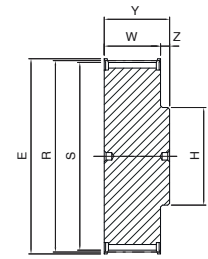

1

ST ... S8M20

8M

Code	Nb de dents	Type	E [mm]	R [mm]	S [mm]	U [mm]	H [mm]	d [mm]	W [mm]	Y [mm]	Z [mm]	Flasque	Matière
ST18S8M20	18	1	50,0	45,84	44,46	-	32,0	-	28,0	38,0	10,0	avec flasques	acier
ST20S8M20	20	1	55,0	50,93	49,56	-	36,0	-	28,0	38,0	10,0		
ST22S8M20	22	1	62,0	56,02	54,65	-	43,0	-	28,0	38,0	10,0		
ST24S8M20	24	1	67,0	61,12	59,74	-	49,0	-	28,0	38,0	10,0		
ST26S8M20	26	1	73,0	66,21	64,84	-	50,0	-	28,0	38,0	10,0		
ST28S8M20	28	1	77,0	71,30	69,93	-	55,0	-	28,0	38,0	10,0		
ST30S8M20	30	1	84,0	76,39	75,02	-	60,0	-	28,0	38,0	10,0		
ST32S8M20	32	1	88,0	81,49	80,12	-	64,0	-	28,0	38,0	10,0		
ST34S8M20	34	1	94,0	86,58	85,21	-	70,0	-	28,0	38,0	10,0		
ST36S8M20	36	1	98,0	91,67	90,30	-	75,0	-	28,0	38,0	10,0		
ST38S8M20	38	1	104,0	96,77	95,39	-	80,0	-	28,0	38,0	10,0		
ST40S8M20	40	1	108,0	101,86	100,49	-	85,0	-	28,0	38,0	10,0		
ST44S8M20	44	1	121,0	112,05	110,67	-	96,0	-	28,0	38,0	10,0		
ST48S8M20	48	1	129,0	122,23	120,86	-	104,0	-	28,0	38,0	10,0		
ST56S8M20	56	3	149,0	142,60	141,23	117,0	80,0	-	28,0	38,0	10,0		
ST60S8M20	60	3	158,0	152,79	151,42	127,0	80,0	-	28,0	38,0	10,0		
ST64S8M20	64	3	168,0	162,97	161,60	137,0	80,0	-	28,0	38,0	10,0		
ST72S8M20	72	3	191,0	183,35	181,97	158,0	80,0	-	28,0	38,0	10,0		
ST80S8M20	80	3A	-	203,72	202,35	179,0	90,0	-	28,0	38,0	10,0		
ST84S8M20	84	3A	-	213,90	212,53	190,0	90,0	-	28,0	38,0	10,0		
ST90S8M20	90	3A	-	229,18	227,81	204,0	90,0	-	28,0	38,0	10,0		
ST112S8M20	112	5B	-	285,21	283,83	260,0	90,0	19,0	28,0	38,0	10,0		
ST144S8M20	144	5B	-	366,69	365,32	342,0	90,0	19,0	28,0	38,0	10,0		
ST168S8M20	168	5B	-	427,80	426,42	403,0	100,0	19,0	28,0	38,0	10,0		
ST192S8M20	192	5B	-	488,92	487,54	465,0	100,0	19,0	28,0	38,0	10,0		

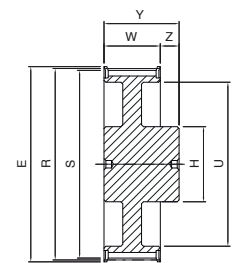

3

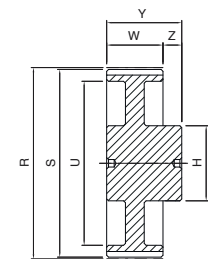

3A

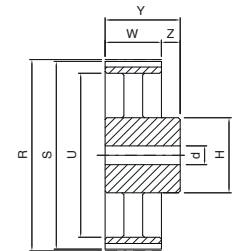

5B

Dimensions des poulies dentées SUPER TORQUE - moyeu plein

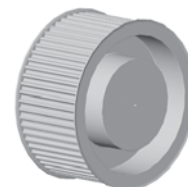

ST ... S8M30

8M

Code	Nb de dents	Type	E [mm]	R [mm]	S [mm]	U [mm]	H [mm]	d [mm]	W [mm]	Y [mm]	Z [mm]	Flasque	Matière
ST18S8M30	18	1	50,0	45,84	44,46	-	32,0	-	38,0	48,0	10,0	avec flasques	acier
ST20S8M30	20	1	55,0	50,93	49,56	-	36,0	-	38,0	48,0	10,0		
ST22S8M30	22	1	62,0	56,02	54,65	-	43,0	-	38,0	48,0	10,0		
ST24S8M30	24	1	67,0	61,12	59,74	-	49,0	-	38,0	48,0	10,0		
ST26S8M30	26	1	73,0	66,21	64,84	-	50,0	-	38,0	48,0	10,0		
ST28S8M30	28	1	77,0	71,30	69,93	-	55,0	-	38,0	48,0	10,0		
ST30S8M30	30	1	84,0	76,39	75,02	-	60,0	-	38,0	48,0	10,0		
ST32S8M30	32	1	88,0	81,49	80,12	-	64,0	-	38,0	48,0	10,0		
ST34S8M30	34	1	94,0	86,58	85,21	-	70,0	-	38,0	48,0	10,0		
ST36S8M30	36	1	98,0	91,67	90,30	-	75,0	-	38,0	48,0	10,0		
ST38S8M30	38	1	104,0	96,77	95,39	-	80,0	-	38,0	48,0	10,0		
ST40S8M30	40	1	108,0	101,86	100,49	-	85,0	-	38,0	48,0	10,0		
ST44S8M30	44	1	121,0	112,05	110,67	-	96,0	-	38,0	48,0	10,0		
ST48S8M30	48	1	129,0	122,23	120,86	-	104,0	-	38,0	48,0	10,0		
ST56S8M30	56	3	149,0	142,60	141,23	117,0	90,0	-	38,0	48,0	10,0		
ST60S8M30	60	3	158,0	152,79	151,42	127,0	90,0	-	38,0	48,0	10,0		
ST64S8M30	64	3	168,0	162,97	161,60	137,0	90,0	-	38,0	48,0	10,0		
ST72S8M30	72	3	191,0	183,35	181,97	158,0	95,0	-	38,0	48,0	10,0		
ST80S8M30	80	3A	-	203,72	202,35	179,0	100,0	-	38,0	48,0	10,0		
ST84S8M30	84	3A	-	213,90	212,53	190,0	100,0	-	38,0	48,0	10,0		
ST90S8M30	90	3A	-	229,18	227,81	204,0	100,0	-	38,0	48,0	10,0		
ST112S8M30	112	5B	-	285,21	283,83	260,0	100,0	19,0	38,0	48,0	10,0		
ST144S8M30	144	5B	-	366,69	365,32	342,0	100,0	19,0	38,0	48,0	10,0		
ST168S8M30	168	5B	-	427,80	426,42	403,0	100,0	19,0	38,0	48,0	10,0		
ST192S8M30	192	5B	-	488,92	487,54	465,0	100,0	19,0	38,0	48,0	10,0		

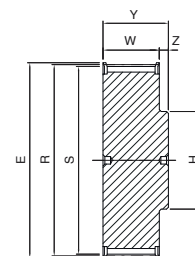

1

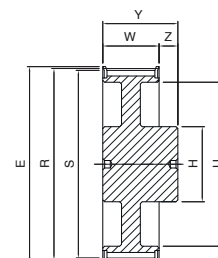

3

ST ... S8M50

8M

Code	Nb de dents	Type	E [mm]	R [mm]	S [mm]	U [mm]	H [mm]	d [mm]	W [mm]	Y [mm]	Z [mm]	Flasque	Matière
ST18S8M50	18	1	50,0	45,84	44,46	-	32,0	-	60,0	70,0	10,0	avec flasques	acier
ST20S8M50	20	1	55,0	50,93	49,56	-	36,0	-	60,0	70,0	10,0		
ST22S8M50	22	1	62,0	56,02	54,65	-	43,0	-	60,0	70,0	10,0		
ST24S8M50	24	1	67,0	61,12	59,74	-	49,0	-	60,0	70,0	10,0		
ST26S8M50	26	1	73,0	66,21	64,84	-	50,0	-	60,0	70,0	10,0		
ST28S8M50	28	1	77,0	71,30	69,93	-	55,0	-	60,0	70,0	10,0		
ST30S8M50	30	1	84,0	76,39	75,02	-	60,0	-	60,0	70,0	10,0		
ST32S8M50	32	1	88,0	81,49	80,12	-	64,0	-	60,0	70,0	10,0		
ST34S8M50	34	1	94,0	86,58	85,21	-	70,0	-	60,0	70,0	10,0		
ST36S8M50	36	1	98,0	91,67	90,30	-	75,0	-	60,0	70,0	10,0		
ST38S8M50	38	1	104,0	96,77	95,39	-	80,0	-	60,0	70,0	10,0		
ST40S8M50	40	1	108,0	101,86	100,49	-	85,0	-	60,0	70,0	10,0		
ST44S8M50	44	1	121,0	112,05	110,67	-	96,0	-	60,0	70,0	10,0		
ST48S8M50	48	1	129,0	122,23	120,86	-	104,0	-	60,0	70,0	10,0		
ST56S8M50	56	6	149,0	142,60	141,23	117,0	90,0	-	60,0	60,0	-		
ST60S8M50	60	6	158,0	152,79	151,42	127,0	100,0	-	60,0	60,0	-		
ST64S8M50	64	6	168,0	162,97	161,60	137,0	100,0	-	60,0	60,0	-		
ST72S8M50	72	6	191,0	183,35	181,97	158,0	100,0	-	60,0	60,0	-		
ST80S8M50	80	6A	-	203,72	202,35	179,0	110,0	-	60,0	60,0	-		
ST84S8M50	84	6A	-	213,90	212,53	190,0	110,0	-	60,0	60,0	-		
ST90S8M50	90	6A	-	229,18	227,81	204,0	110,0	-	60,0	60,0	-		
ST112S8M50	112	7B	-	285,21	283,83	260,0	110,0	19,0	60,0	60,0	-		
ST144S8M50	144	7B	-	366,69	365,32	342,0	110,0	19,0	60,0	60,0	-		
ST168S8M50	168	7B	-	427,80	426,42	403,0	120,0	19,0	60,0	60,0	-		
ST192S8M50	192	7B	-	488,92	487,54	465,0	130,0	19,0	60,0	60,0	-		

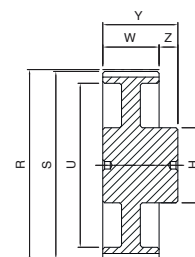

3A

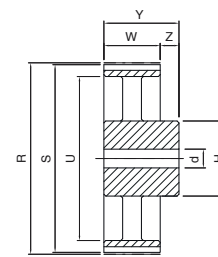

5B

Dimensions des poulies dentées SUPER TORQUE - moyeu plein



ST ... S8M85

8M

Code	Nb de dents	Type	E [mm]	R [mm]	S [mm]	U [mm]	H [mm]	d [mm]	W [mm]	Y [mm]	Z [mm]	Flasque	Matière
ST22S8M85	22	1	62,0	56,02	54,65	-	43,0	-	95,0	105,0	10,0	avec flasques	acier
ST24S8M85	24	1	67,0	61,12	59,74	-	49,0	-	95,0	105,0	10,0		
ST26S8M85	26	1	73,0	66,21	64,84	-	50,0	-	95,0	105,0	10,0		
ST28S8M85	28	1	77,0	71,30	69,93	-	55,0	-	95,0	105,0	10,0		
ST30S8M85	30	1	84,0	76,39	75,02	-	60,0	-	95,0	105,0	10,0		
ST32S8M85	32	1	88,0	81,49	80,12	-	64,0	-	95,0	105,0	10,0		
ST34S8M85	34	1	94,0	86,58	85,21	-	70,0	-	95,0	105,0	10,0		
ST36S8M85	36	1	98,0	91,67	90,30	-	75,0	-	95,0	105,0	10,0		
ST38S8M85	38	1	104,0	96,77	95,39	-	80,0	-	95,0	105,0	10,0		
ST40S8M85	40	1	108,0	101,86	100,49	-	85,0	-	95,0	105,0	10,0		
ST44S8M85	44	1	121,0	112,05	110,67	-	96,0	-	95,0	105,0	10,0		
ST48S8M85	48	1	129,0	122,23	120,86	-	104,0	-	95,0	105,0	10,0		
ST56S8M85	56	1	149,0	142,60	141,23	-	107,0	-	95,0	105,0	10,0		
ST60S8M85	60	1	158,0	152,79	151,42	-	132,0	-	95,0	105,0	10,0		
ST64S8M85	64	6	168,0	162,97	161,60	137,0	100,0	-	95,0	95,0	-		
ST72S8M85	72	6	191,0	183,35	181,97	158,0	110,0	-	95,0	95,0	-		
ST80S8M85	80	6A	-	203,72	202,35	179,0	110,0	-	95,0	95,0	-		
ST84S8M85	84	6A	-	213,90	212,53	190,0	110,0	-	95,0	95,0	-		
ST90S8M85	90	6B	-	229,18	227,81	204,0	110,0	-	95,0	95,0	-		
ST112S8M85	112	7B	-	285,21	283,83	260,0	110,0	19,0	95,0	95,0	-		
ST144S8M85	144	7B	-	366,69	365,32	342,0	120,0	19,0	95,0	95,0	-		
ST168S8M85	168	7B	-	427,80	426,42	403,0	120,0	19,0	95,0	95,0	-		
ST192S8M85	192	7B	-	488,92	487,54	465,0	130,0	19,0	95,0	95,0	-		

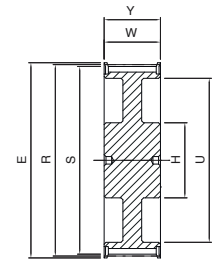

6

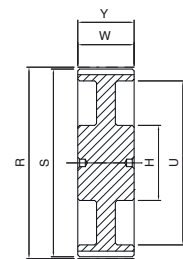

6A

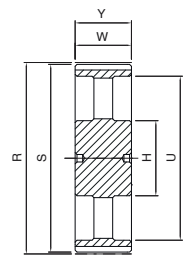

6B

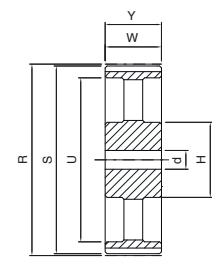

7B

ST ... S14M40

14M

Code	Nb de dents	Type	E [mm]	R [mm]	S [mm]	U [mm]	H [mm]	d [mm]	W [mm]	Y [mm]	Z [mm]	Flasque	Matière
ST28S14M40	28	1	134,0	124,78	121,98	-	100,0	-	54,0	69,0	15,0	avec flasques	fonte
ST29S14M40	29	1	134,0	129,23	126,44	-	107,0	-	54,0	69,0	15,0		
ST30S14M40	30	1	142,0	133,69	130,90	-	107,0	-	54,0	69,0	15,0		
ST32S14M40	32	1	150,0	142,60	139,81	-	114,0	-	54,0	69,0	15,0		
ST34S14M40	34	1	158,0	151,51	148,72	-	122,0	-	54,0	69,0	15,0		
ST36S14M40	36	1	166,0	160,43	157,63	-	128,0	-	54,0	69,0	15,0		
ST38S14M40	38	1	177,0	169,34	166,55	-	141,0	-	54,0	69,0	15,0		
ST40S14M40	40	1	186,0	178,25	175,46	-	148,0	-	54,0	69,0	15,0		
ST44S14M40	44	3	209,0	196,08	193,28	154,0	120,0	-	54,0	69,0	15,0		
ST48S14M40	48	3	216,0	213,90	211,11	172,0	135,0	-	54,0	69,0	15,0		
ST56S14M40	56	3	261,0	249,56	246,76	207,0	135,0	-	54,0	69,0	15,0		
ST60S14M40	60	3	274,0	267,38	264,59	225,0	135,0	-	54,0	69,0	15,0		
ST64S14M40	64	3	288,0	285,21	282,41	243,0	135,0	-	54,0	69,0	15,0		
ST72S14M40	72	5B	-	320,86	318,06	279,0	135,0	19,0	54,0	69,0	15,0		
ST80S14M40	80	5B	-	356,51	353,71	314,0	135,0	19,0	54,0	69,0	15,0		
ST84S14M40	84	5B	-	374,33	371,54	332,0	135,0	19,0	54,0	69,0	15,0		
ST90S14M40	90	5B	-	401,07	398,28	359,0	135,0	19,0	54,0	69,0	15,0		
ST112S14M40	112	5B	-	499,11	496,32	457,0	135,0	19,0	54,0	69,0	15,0		
ST144S14M40	144	5B	-	641,71	638,92	600,0	135,0	19,0	54,0	69,0	15,0		

Dimensions des poulies dentées SUPER TORQUE - moyeu plein

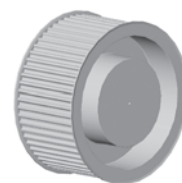

ST ... S14M55

14M

Code	Nb de dents	Type	E [mm]	R [mm]	S [mm]	U [mm]	H [mm]	d [mm]	W [mm]	Y [mm]	Z [mm]	Flasque	Matière
ST28S14M55	28	1	134,0	124,78	121,98	-	100,0	-	70,0	85,0	15,0	avec flasques	fonte
ST29S14M55	29	1	134,0	129,23	126,44	-	107,0	-	70,0	85,0	15,0		
ST30S14M55	30	1	142,0	133,69	130,90	-	107,0	-	70,0	85,0	15,0		
ST32S14M55	32	1	150,0	142,60	139,81	-	114,0	-	70,0	85,0	15,0		
ST34S14M55	34	1	158,0	151,51	148,72	-	122,0	-	70,0	85,0	15,0		
ST36S14M55	36	1	166,0	160,43	157,63	-	128,0	-	70,0	85,0	15,0		
ST38S14M55	38	1	177,0	169,34	166,55	-	141,0	-	70,0	85,0	15,0		
ST40S14M55	40	1	186,0	178,25	175,46	-	148,0	-	70,0	85,0	15,0		
ST44S14M55	44	3	209,0	196,08	193,28	154,0	120,0	-	70,0	85,0	15,0		
ST48S14M55	48	6	216,0	213,90	211,11	172,0	135,0	-	70,0	70,0	-		
ST56S14M55	56	6	261,0	249,56	246,76	207,0	135,0	-	70,0	70,0	-		
ST60S14M55	60	6	274,0	267,38	264,59	225,0	135,0	-	70,0	70,0	-		
ST64S14M55	64	6	288,0	285,21	282,41	243,0	135,0	-	70,0	70,0	-		
ST72S14M55	72	7B	-	320,86	318,06	279,0	135,0	19,0	70,0	70,0	-		
ST80S14M55	80	7B	-	356,51	353,71	314,0	135,0	19,0	70,0	70,0	-		
ST84S14M55	84	7B	-	374,33	371,54	332,0	135,0	19,0	70,0	70,0	-		
ST90S14M55	90	7B	-	401,07	398,28	359,0	135,0	19,0	70,0	70,0	-		
ST112S14M55	112	7B	-	499,11	496,32	457,0	135,0	19,0	70,0	70,0	-		
ST144S14M55	144	7B	-	641,71	638,92	600,0	135,0	19,0	70,0	70,0	-		

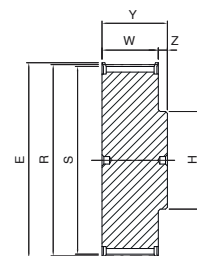

1

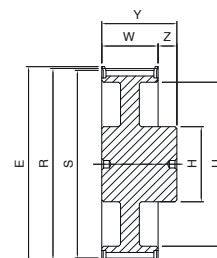

3

ST ... S14M85

14M

Code	Nb de dents	Type	E [mm]	R [mm]	S [mm]	U [mm]	H [mm]	d [mm]	W [mm]	Y [mm]	Z [mm]	Flasque	Matière
ST28S14M85	28	1	134,0	124,78	121,98	-	100,0	-	102,0	117,0	15,0	avec flasques	fonte
ST29S14M85	29	1	134,0	129,23	126,44	-	107,0	-	102,0	117,0	15,0		
ST30S14M85	30	1	142,0	133,69	130,90	-	107,0	-	102,0	117,0	15,0		
ST32S14M85	32	1	150,0	142,60	139,81	-	114,0	-	102,0	117,0	15,0		
ST34S14M85	34	1	158,0	151,51	148,72	-	122,0	-	102,0	117,0	15,0		
ST36S14M85	36	1	166,0	160,43	157,63	-	128,0	-	102,0	117,0	15,0		
ST38S14M85	38	1	177,0	169,34	166,55	-	141,0	-	102,0	117,0	15,0		
ST40S14M85	40	1	186,0	178,25	175,46	-	148,0	-	102,0	117,0	15,0		
ST44S14M85	44	1	209,0	196,08	193,28	-	169,0	-	102,0	117,0	15,0		
ST48S14M85	48	1	216,0	213,90	211,11	-	186,0	-	102,0	117,0	15,0		
ST56S14M85	56	6	261,0	249,56	246,76	207,0	150,0	-	102,0	102,0	-		
ST60S14M85	60	6	274,0	267,38	264,59	225,0	150,0	-	102,0	102,0	-		
ST64S14M85	64	6	288,0	285,21	282,41	243,0	150,0	-	102,0	102,0	-		
ST72S14M85	72	7B	-	320,86	318,06	279,0	150,0	19,0	102,0	102,0	-		
ST80S14M85	80	7B	-	356,51	353,71	314,0	150,0	19,0	102,0	102,0	-		
ST84S14M85	84	7B	-	374,33	371,54	332,0	150,0	19,0	102,0	102,0	-		
ST90S14M85	90	7B	-	401,07	398,28	359,0	150,0	19,0	102,0	102,0	-		
ST112S14M85	112	7B	-	499,11	496,32	457,0	150,0	19,0	102,0	102,0	-		
ST144S14M85	144	7B	-	641,71	638,92	600,0	150,0	19,0	102,0	102,0	-		

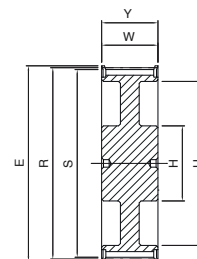

6

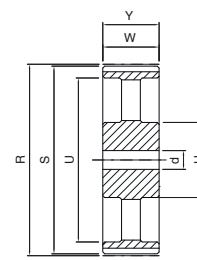

7B

Dimensions des poulies dentées SUPER TORQUE - moyeu plein



ST ... S14M115

14M

Code	Nb de dents	Type	E [mm]	R [mm]	S [mm]	U [mm]	H [mm]	d [mm]	W [mm]	Y [mm]	Z [mm]	Flasque	Matière
ST28S14M115	28	1	134,0	124,78	121,98	-	100,0	-	133,0	148,0	15,0	avec flasques	fonte
ST29S14M115	29	1	134,0	129,23	126,44	-	107,0	-	133,0	148,0	15,0		
ST30S14M115	30	1	142,0	133,69	130,90	-	107,0	-	133,0	148,0	15,0		
ST32S14M115	32	1	150,0	142,60	139,81	-	114,0	-	133,0	148,0	15,0		
ST34S14M115	34	1	158,0	151,51	148,72	-	122,0	-	133,0	148,0	15,0		
ST36S14M115	36	1	166,0	160,43	157,63	-	128,0	-	133,0	148,0	15,0		
ST38S14M115	38	1	177,0	169,34	166,55	-	141,0	-	133,0	148,0	15,0		
ST40S14M115	40	1	186,0	178,25	175,46	-	148,0	-	133,0	148,0	15,0		
ST44S14M115	44	1	209,0	196,08	193,28	-	169,0	-	133,0	148,0	15,0		
ST48S14M115	48	1	216,0	213,90	211,11	-	186,0	-	133,0	148,0	15,0		
ST56S14M115	56	3	261,0	249,56	246,76	207,0	150,0	-	133,0	133,0	-		
ST60S14M115	60	6	274,0	267,38	264,59	225,0	150,0	-	133,0	133,0	-		
ST64S14M115	64	6	288,0	285,21	282,41	243,0	150,0	-	133,0	133,0	-		
ST72S14M115	72	7B	-	320,86	318,06	279,0	150,0	19,0	133,0	133,0	-		
ST80S14M115	80	7B	-	356,51	353,71	314,0	150,0	19,0	133,0	133,0	-		
ST84S14M115	84	7B	-	374,33	371,54	332,0	150,0	19,0	133,0	133,0	-		
ST90S14M115	90	7B	-	401,07	398,28	359,0	150,0	19,0	133,0	133,0	-		
ST112S14M115	112	7B	-	499,11	496,32	457,0	150,0	19,0	133,0	133,0	-		
ST144S14M115	144	7B	-	641,71	638,92	600,0	150,0	19,0	133,0	133,0	-		

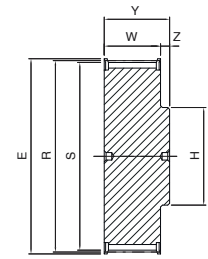

1

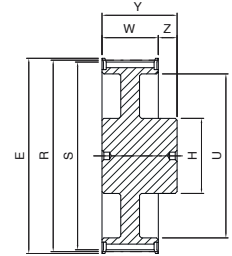

3

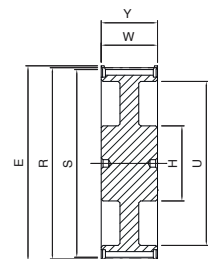

6

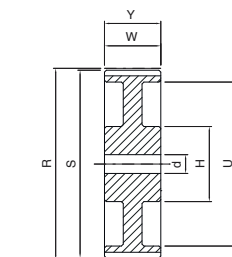

7A

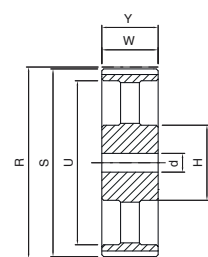

7B

ST ... S14M170

14M

Code	Nb de dents	Type	E [mm]	R [mm]	S [mm]	U [mm]	H [mm]	d [mm]	W [mm]	Y [mm]	Z [mm]	Flasque	Matière
ST28S14M170	28	1	134,0	124,78	121,98	-	100,0	-	187,0	202,0	15,0	avec flasques	fonte
ST29S14M170	29	1	134,0	129,23	126,44	-	107,0	-	187,0	202,0	15,0		
ST30S14M170	30	1	142,0	133,69	130,90	-	107,0	-	187,0	202,0	15,0		
ST32S14M170	32	1	150,0	142,60	139,81	-	114,0	-	187,0	202,0	15,0		
ST34S14M170	34	1	158,0	151,51	148,72	-	122,0	-	187,0	202,0	15,0		
ST36S14M170	36	1	166,0	160,43	157,63	-	128,0	-	187,0	202,0	15,0		
ST38S14M170	38	1	177,0	169,34	166,55	-	141,0	-	187,0	202,0	15,0		
ST40S14M170	40	1	186,0	178,25	175,46	-	148,0	-	187,0	202,0	15,0		
ST44S14M170	44	1	209,0	196,08	193,28	-	169,0	-	187,0	202,0	15,0		
ST48S14M170	48	1	216,0	213,90	211,11	-	186,0	-	187,0	202,0	15,0		
ST56S14M170	56	3	261,0	249,56	246,76	207,0	160,0	-	187,0	202,0	15,0		
ST60S14M170	60	3	274,0	267,38	264,59	225,0	160,0	-	187,0	202,0	15,0		
ST64S14M170	64	3	288,0	285,21	282,41	243,0	180,0	-	187,0	202,0	15,0		
ST72S14M170	72	7A	-	320,86	318,06	279,0	180,0	19,0	187,0	187,0	-		
ST80S14M170	80	7A	-	356,51	353,71	314,0	180,0	19,0	187,0	187,0	-		
ST84S14M170	84	7B	-	374,33	371,54	332,0	180,0	19,0	187,0	187,0	-		
ST90S14M170	90	7B	-	401,07	398,28	359,0	180,0	19,0	187,0	187,0	-		
ST112S14M170	112	7B	-	499,11	496,32	457,0	200,0	19,0	187,0	187,0	-		
ST144S14M170	144	7B	-	641,71	638,92	600,0	220,0	19,0	187,0	187,0	-		

Dimensions des poulies dentées SUPER TORQUE

- moyeu amovible SER-SIT®

Types 8M - 14M



Désignation **STB 32 S 8M 20**

poulie SUPER TORQUE - moyeu amovible

Nombre de dents

Pas

Largeur de la courroie en mm

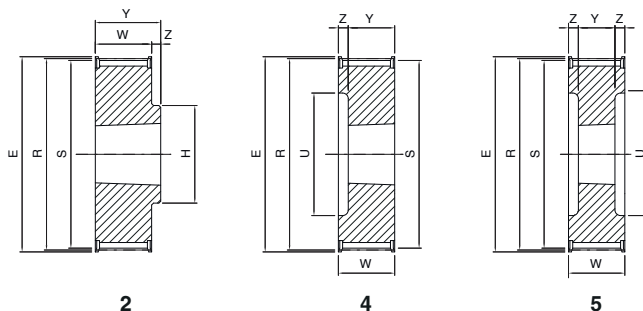

STB ... S8M 20

Code	Nb de dents	Type	Moyeu amovible SER-SIT®	E [mm]	R [mm]	S [mm]	U [mm]	H [mm]	W [mm]	Y [mm]	Z [mm]	Flasque	Matière
STB22S8M20	22	4	1008	62,0	56,02	54,65	38,0	-	28,0	22,0	6,0	avec flasques	fonte
STB24S8M20	24	4	1108	67,0	61,12	59,74	42,0	-	28,0	22,0	6,0		
STB26S8M20	26	4	1108	73,0	66,21	64,84	45,0	-	28,0	22,0	6,0		
STB28S8M20	28	4	1108	77,0	71,30	69,93	52,0	-	28,0	22,0	6,0		
STB30S8M20	30	4	1108	84,0	76,39	75,02	56,0	-	28,0	22,0	6,0		
STB32S8M20	32	4	1610	88,0	81,49	80,12	65,0	-	28,0	25,0	3,0		
STB34S8M20	34	4	1610	94,0	86,58	85,21	66,0	-	28,0	25,0	3,0		
STB36S8M20	36	4	1610	98,0	91,67	90,30	68,0	-	28,0	25,0	3,0		
STB38S8M20	38	4	1610	104,0	96,77	95,39	76,0	-	28,0	25,0	3,0		
STB40S8M20	40	4	1610	108,0	101,86	100,49	80,0	-	28,0	25,0	3,0		
STB44S8M20	44	2	2012	121,0	112,05	110,67	-	99,0	28,0	32,0	4,0		
STB48S8M20	48	2	2012	129,0	122,23	120,86	-	105,0	28,0	32,0	4,0		
STB56S8M20	56	2	2012	149,0	142,60	141,23	-	105,0	28,0	32,0	4,0		
STB64S8M20	64	9	2012	168,0	162,97	161,60	140,0	110,0	28,0	32,0	4,0		
STB72S8M20	72	9	2012	191,0	183,35	181,97	158,0	110,0	28,0	32,0	4,0		
STB80S8M20	80	9A	2012	-	203,72	202,35	178,0	110,0	28,0	32,0	4,0		
STB90S8M20	90	9B	2012	-	229,18	227,81	204,0	110,0	28,0	32,0	4,0		

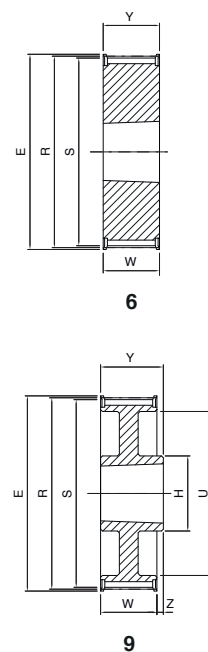

STB ... S8M 30

Code	Nb de dents	Type	Moyeu amovible SER-SIT®	E [mm]	R [mm]	S [mm]	U [mm]	H [mm]	W [mm]	Y [mm]	Z [mm]	Flasque	Matière
STB22S8M30	22	4	1008	62,0	56,02	54,65	38,0	-	38,0	22,0	16,0	avec flasques	fonte
STB24S8M30	24	4	1108	67,0	61,12	59,74	42,0	-	38,0	22,0	16,0		
STB26S8M30	26	4	1108	73,0	66,21	64,84	45,0	-	38,0	22,0	16,0		
STB28S8M30	28	4	1108	77,0	71,30	69,93	52,0	-	38,0	22,0	16,0		
STB30S8M30	30	6	1615	84,0	76,39	75,02	-	-	38,0	38,0	-		
STB32S8M30	32	6	1615	88,0	81,49	80,12	-	-	38,0	38,0	-		
STB34S8M30	34	6	1615	94,0	86,58	85,21	-	-	38,0	38,0	-		
STB36S8M30	36	6	1615	98,0	91,67	90,30	-	-	38,0	38,0	-		
STB38S8M30	38	6	1615	104,0	96,77	95,39	-	-	38,0	38,0	-		
STB40S8M30	40	6	1615	108,0	101,86	100,49	-	-	38,0	38,0	-		
STB44S8M30	44	5	2012	121,0	112,05	110,67	90,0	-	38,0	32,0	-		
STB48S8M30	48	5	2012	129,0	122,23	120,86	98,0	-	38,0	32,0	3,0		
STB56S8M30	56	5	2012	149,0	142,60	141,23	118,0	-	38,0	32,0	3,0		
STB64S8M30	64	9	2517	168,0	162,97	161,6	140,0	120,0	38,0	45,0	3,0		
STB72S8M30	72	9	2517	191,0	183,35	181,97	158,0	120,0	38,0	45,0	7,0		
STB80S8M30	80	9A	2517	-	203,72	202,35	178,0	120,0	38,0	45,0	7,0		
STB90S8M30	90	9B	2517	-	229,18	227,81	204,0	120,0	38,0	45,0	7,0		
STB112S8M30	112	9B	2517	-	285,21	283,83	260,0	120,0	38,0	45,0	7,0		
STB144S8M30	144	9B	2517	-	366,69	365,32	341,0	120,0	38,0	45,0	7,0		

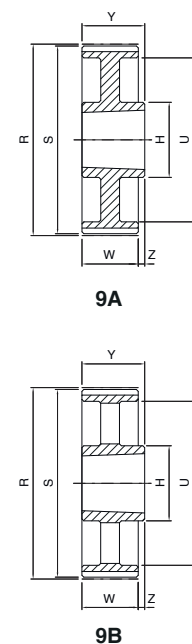

Dimensions des poulies dentées SUPER TORQUE - moyeu amovible SER-SIT®



STB ... S8M 50

8M

Code	Nb de dents	Type	Moyeu amovible SER-SIT®	E [mm]	R [mm]	S [mm]	U [mm]	H [mm]	W [mm]	Y [mm]	Z [mm]	Flasque	Matière
STB28S8M50	28	5	1108	77,0	71,30	69,93	52,0	-	60,0	22,0	19,0	avec flasques	fonte
STB30S8M50	30	4	1615	84,0	76,39	75,02	58,0	-	60,0	38,0	22,0		
STB32S8M50	32	4	1615	88,0	81,49	80,12	60,0	-	60,0	38,0	22,0		
STB34S8M50	34	4	1615	94,0	86,58	85,21	66,0	-	60,0	38,0	22,0		
STB36S8M50	36	4	1615	98,0	91,67	90,30	68,0	-	60,0	38,0	22,0		
STB38S8M50	38	4	1615	104,0	96,77	95,39	75,0	-	60,0	38,0	22,0		
STB40S8M50	40	5	2012	108,0	101,86	100,49	80,0	-	60,0	32,0	14,0		
STB44S8M50	44	5	2012	121,0	112,05	110,67	90,0	-	60,0	32,0	14,0		
STB48S8M50	48	5	2012	129,0	122,23	120,86	100,0	-	60,0	32,0	14,0		
STB56S8M50	56	5	2517	149,0	142,60	141,23	120,0	-	60,0	45,0	7,5		
STB64S8M50	64	8	2517	168,0	162,97	161,60	138,0	120,0	60,0	45,0	7,5		
STB72S8M50	72	8	2517	191,0	183,35	181,97	158,0	120,0	60,0	45,0	7,5		
STB80S8M50	80	8A	3020	-	203,72	202,35	178,0	160,0	60,0	51,0	4,5		
STB90S8M50	90	8A	3020	-	229,18	227,81	204,0	160,0	60,0	51,0	4,5		
STB112S8M50	112	8B	3020	-	285,21	283,83	260,0	160,0	60,0	51,0	4,5		
STB144S8M50	144	8B	3020	-	366,69	365,32	341,0	160,0	60,0	51,0	4,5		
STB168S8M50	168	8B	3020	-	427,80	426,42	402,0	160,0	60,0	51,0	4,5		
STB192S8M50	192	8B	3020	-	488,92	487,54	462,0	160,0	60,0	51,0	4,5		

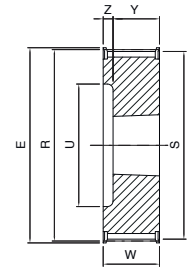

4

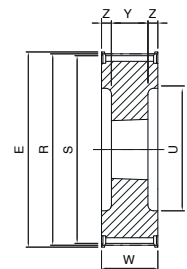

5

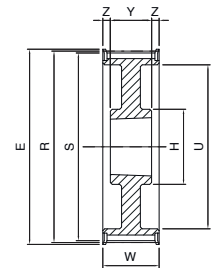

8

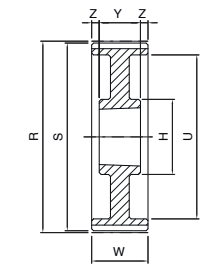

8A

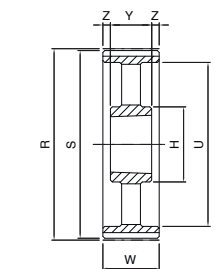

8B

STB ... S8M 85

8M

Code	Nb de dents	Type	Moyeu amovible SER-SIT®	E [mm]	R [mm]	S [mm]	U [mm]	H [mm]	W [mm]	Y [mm]	Z [mm]	Flasque	Matière
STB34S8M85	34	5	1615	94,0	86,58	85,21	66,0	-	95,0	38,0	28,5	avec flasques	fonte
STB36S8M85	36	5	1615	98,0	91,67	90,30	68,0	-	95,0	38,0	28,5		
STB38S8M85	38	5	1615	104,0	96,77	95,39	75,0	-	95,0	38,0	28,5		
STB40S8M85	40	5	2012	108,0	101,86	100,49	80,0	-	95,0	32,0	31,5		
STB44S8M85	44	5	2012	121,0	112,05	110,67	90,0	-	95,0	32,0	31,5		
STB48S8M85	48	5	2517	129,0	122,23	120,86	100,0	-	95,0	45,0	25,0		
STB56S8M85	56	5	2517	149,0	142,60	141,23	120,0	-	95,0	45,0	25,0		
STB64S8M85	64	5	2517	168,0	162,97	161,60	138,0	-	95,0	45,0	25,0		
STB72S8M85	72	5	3020	191,0	183,35	181,97	158,0	-	95,0	51,0	22,0		
STB80S8M85	80	8A	3020	-	203,72	202,35	178,0	160,0	95,0	51,0	22,0		
STB90S8M85	90	8A	3020	-	229,18	227,81	204,0	160,0	95,0	51,0	22,0		
STB112S8M85	112	8B	3020	-	285,21	283,83	260,0	160,0	95,0	51,0	22,0		
STB144S8M85	144	8B	3030	-	366,69	365,32	341,0	160,0	95,0	76,0	9,5		
STB168S8M85	168	8B	3030	-	427,80	426,42	402,0	160,0	95,0	76,0	9,5		
STB192S8M85	192	8B	3030	-	488,92	487,54	462,0	160,0	95,0	76,0	9,5		

Dimensions des poulies dentées SUPER TORQUE - moyeu amovible SER-SIT®

STB ... S14M 40

14M



Code	Nb de dents	Type	Moyeu amovible SER-SIT®	E [mm]	R [mm]	S [mm]	U [mm]	H [mm]	W [mm]	Y [mm]	Z [mm]	Flasque	Matière
STB28S14M40	28	5	2012	134,0	124,78	121,98	98,0	-	54,0	32,0	11,0	avec flasques	fonte
STB29S14M40	29	5	2012	134,0	129,23	126,44	100,0	-	54,0	32,0	11,0		
STB30S14M40	30	5	2012	142,0	133,69	130,90	100,0	-	54,0	32,0	11,0		
STB32S14M40	32	5	2012	150,0	142,60	139,81	104,0	-	54,0	32,0	11,0		
STB34S14M40	34	5	2517	158,0	151,51	148,72	110,0	-	54,0	45,0	4,5		
STB36S14M40	36	5	2517	166,0	160,43	157,63	120,0	-	54,0	45,0	4,5		
STB38S14M40	38	5	2517	177,0	169,34	166,55	130,0	-	54,0	45,0	4,5		
STB40S14M40	40	5	2517	186,0	178,25	175,46	138,0	-	54,0	45,0	4,5		
STB44S14M40	44	5	3020	209,0	196,08	193,28	154,0	-	54,0	51,0	1,5		
STB48S14M40	48	5	3020	216,0	213,90	211,11	172,0	-	54,0	51,0	1,5		
STB56S14M40	56	8	3020	261,0	249,56	246,76	207,0	160,0	54,0	51,0	1,5		
STB64S14M40	64	8	3020	288,0	285,21	282,41	243,0	160,0	54,0	51,0	1,5		
STB72S14M40	72	8A	3020	-	320,86	318,06	279,0	160,0	54,0	51,0	1,5		
STB80S14M40	80	8B	3020	-	356,51	353,71	314,0	160,0	54,0	51,0	1,5		
STB90S14M40	90	8B	3020	-	401,07	398,28	359,0	160,0	54,0	51,0	1,5		
STB112S14M40	112	8B	3020	-	499,11	496,32	457,0	160,0	54,0	51,0	1,5		
STB144S14M40	144	8B	3020	-	641,71	638,92	600,0	160,0	54,0	51,0	1,5		

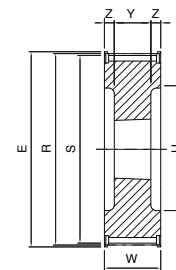

5

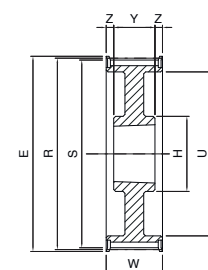

8

STB ... S14M 55

14M

Code	Nb de dents	Type	Moyeu amovible SER-SIT®	E [mm]	R [mm]	S [mm]	U [mm]	H [mm]	W [mm]	Y [mm]	Z [mm]	Flasque	Matière
STB28S14M55	28	5	2012	134,0	124,78	121,98	98,0	-	70,0	32,0	19,0	avec flasques	fonte
STB29S14M55	29	5	2012	134,0	129,23	126,44	100,0	-	70,0	32,0	19,0		
STB30S14M55	30	5	2517	142,0	133,69	130,90	100,0	-	70,0	45,0	12,5		
STB32S14M55	32	5	2517	150,0	142,60	139,81	104,0	-	70,0	45,0	12,5		
STB34S14M55	34	5	2517	158,0	151,51	148,72	110,0	-	70,0	45,0	12,5		
STB36S14M55	36	5	2517	166,0	160,43	157,63	120,0	-	70,0	45,0	12,5		
STB38S14M55	38	5	2517	177,0	169,34	166,55	130,0	-	70,0	45,0	12,5		
STB40S14M55	40	5	2517	186,0	178,25	175,46	138,0	-	70,0	45,0	12,5		
STB44S14M55	44	5	3020	209,0	196,08	193,28	154,0	-	70,0	51,0	9,5		
STB48S14M55	48	5	3020	216,0	213,90	211,11	172,0	-	70,0	51,0	9,5		
STB56S14M55	56	8	3020	261,0	249,56	246,76	207,0	160,0	70,0	51,0	9,5		
STB64S14M55	64	8	3020	288,0	285,21	282,41	243,0	160,0	70,0	51,0	9,5		
STB72S14M55	72	8A	3020	-	320,86	318,06	279,0	160,0	70,0	51,0	9,5		
STB80S14M55	80	8B	3020	-	356,51	353,71	314,0	160,0	70,0	51,0	9,5		
STB90S14M55	90	8B	3020	-	401,07	398,28	359,0	160,0	70,0	51,0	9,5		
STB112S14M55	112	8B	3020	-	499,11	496,32	457,0	160,0	70,0	51,0	9,5		
STB144S14M55	144	8B	3020	-	641,71	638,92	600,0	160,0	70,0	51,0	9,5		

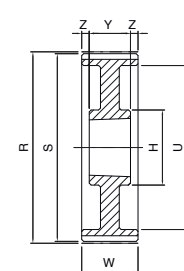

8A

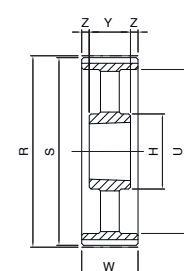

8B

Dimensions des poulies dentées SUPER TORQUE - moyeu amovible SER-SIT®

STB ... S14M 85

14M



Code	Nb de dents	Type	Moyeu amovible SER-SIT®	E [mm]	R [mm]	S [mm]	U [mm]	H [mm]	W [mm]	Y [mm]	Z [mm]	Flasque	Matière
STB28S14M85	28	5	2517	134,0	124,78	121,98	98,0	-	102,0	45,0	28,5	avec flasques	fonte
STB29S14M85	29	5	2517	134,0	129,23	126,44	100,0	-	102,0	45,0	28,5		
STB30S14M85	30	5	2517	142,0	133,69	130,90	100,0	-	102,0	45,0	28,5		
STB32S14M85	32	5	2517	150,0	142,60	139,81	104,0	-	102,0	45,0	28,5		
STB34S14M85	34	5	2517	158,0	151,51	148,72	110,0	-	102,0	45,0	28,5		
STB36S14M85	36	5	3020	166,0	160,43	157,63	120,0	-	102,0	51,0	25,5		
STB38S14M85	38	5	3020	177,0	169,34	166,55	130,0	-	102,0	51,0	25,5		
STB40S14M85	40	5	3020	186,0	178,25	175,46	138,0	-	102,0	51,0	25,5		
STB44S14M85	44	5	3030	209,0	196,08	193,28	154,0	-	102,0	76,0	13,0		
STB48S14M85	48	5	3030	216,0	213,90	211,11	172,0	-	102,0	76,0	13,0		
STB56S14M85	56	5	3535	261,0	249,56	246,76	207,0	-	102,0	89,0	6,5		
STB64S14M85	64	8	3535	288,0	285,21	282,41	243,0	178,0	102,0	89,0	6,5		
STB72S14M85	72	8A	3535	-	320,86	318,06	279,0	178,0	102,0	89,0	6,5		
STB80S14M85	80	8B	3535	-	356,51	353,71	314,0	178,0	102,0	89,0	6,5		
STB90S14M85	90	8B	3535	-	401,07	398,28	359,0	178,0	102,0	89,0	6,5		
STB112S14M85	112	8B	3535	-	499,11	496,32	457,0	178,0	102,0	89,0	6,5		
STB144S14M85	144	8B	3535	-	641,71	638,92	600,0	178,0	102,0	89,0	6,5		
												sans flasque	

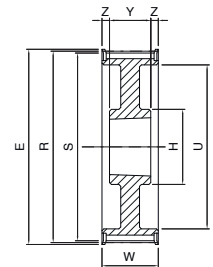
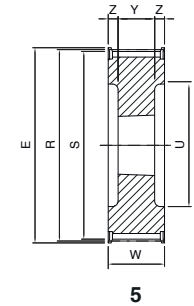

STB ... S14M 115

14M

Code	Nb de dents	Type	Moyeu amovible SER-SIT®	E [mm]	R [mm]	S [mm]	U [mm]	H [mm]	W [mm]	Y [mm]	Z [mm]	Flasque	Matière
STB28S14M115	28	5	2517	134,0	124,78	121,98	98,0	-	133,0	45,0	44,0	avec flasques	fonte
STB29S14M115	29	5	2517	134,0	129,23	126,44	100,0	-	133,0	45,0	44,0		
STB30S14M115	30	5	2517	142,0	133,69	130,90	100,0	-	133,0	45,0	44,0		
STB32S14M115	32	5	2517	150,0	142,60	139,81	104,0	-	133,0	45,0	44,0		
STB34S14M115	34	5	2517	158,0	151,51	148,72	110,0	-	133,0	45,0	44,0		
STB36S14M115	36	5	3020	166,0	160,43	157,63	120,0	-	133,0	51,0	41,0		
STB38S14M115	38	5	3020	177,0	169,34	166,55	130,0	-	133,0	51,0	41,0		
STB40S14M115	40	5	3020	186,0	178,25	175,46	138,0	-	133,0	51,0	41,0		
STB44S14M115	44	5	3030	209,0	196,08	193,28	154,0	-	133,0	76,0	28,5		
STB48S14M115	48	5	3030	216,0	213,90	211,11	172,0	-	133,0	76,0	28,5		
STB56S14M115	56	5	3535	261,0	249,56	246,76	207,0	-	133,0	89,0	22,0		
STB64S14M115	64	8	3535	288,0	285,21	282,41	243,0	178,0	133,0	89,0	22,0		
STB72S14M115	72	8A	3535	-	320,86	318,06	279,0	178,0	133,0	89,0	22,0		
STB80S14M115	80	8B	3535	-	356,51	353,71	314,0	178,0	133,0	89,0	22,0		
STB90S14M115	90	8B	3535	-	401,07	398,28	359,0	178,0	133,0	89,0	22,0		
STB112S14M115	112	8B	3535	-	499,11	496,32	457,0	178,0	133,0	89,0	22,0		
STB144S14M115	144	8B	4040	-	641,71	638,92	600,0	215,0	133,0	102,0	15,5		
												sans flasque	

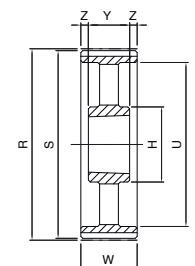
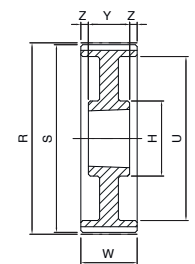

STB ... S14M 170

14M

Code	Nb de dents	Type	Moyeu amovible SER-SIT®	E [mm]	R [mm]	S [mm]	U [mm]	H [mm]	W [mm]	Y [mm]	Z [mm]	Flasque	Matière
STB38S14M170	38	5	3030	177,0	169,34	166,55	130,0	-	187,0	76,0	55,5	avec flasques	fonte
STB40S14M170	40	5	3030	186,0	178,25	175,46	138,0	-	187,0	76,0	55,5		
STB44S14M170	44	5	3535	209,0	196,08	193,28	154,0	-	187,0	89,0	49,0		
STB48S14M170	48	5	3535	216,0	213,90	211,11	172,0	-	187,0	89,0	49,0		
STB56S14M170	56	5	3535	261,0	249,56	246,76	207,0	-	187,0	89,0	49,0		
STB64S14M170	64	5	4040	288,0	285,21	282,41	243,0	-	187,0	102,0	42,5		
STB72S14M170	72	5	4040	-	320,86	318,06	279,0	215,0	187,0	102,0	42,5		
STB80S14M170	80	8A	4040	-	356,51	353,71	314,0	215,0	187,0	102,0	42,5		
STB90S14M170	90	8B	4040	-	401,07	398,28	359,0	215,0	187,0	102,0	42,5		
STB112S14M170	112	8B	5050	-	499,11	496,32	457,0	267,0	187,0	127,0	30,0		
STB144S14M170	144	8B	5050	-	641,71	638,92	600,0	267,0	187,0	127,0	30,0		
												sans flasque	

Les poulies FALCON GTR® produites par SIT ont été spécifiquement conçues et développées pour s'adapter aux courroies FALCON Pd®.

Seule l'utilisation des poulies SIT assure une durée de vie et une performance optimales des systèmes de transmission.

Les poulies FALCON GTR® sont le résultat d'études précises et de nombreux tests en laboratoire grâce auxquels nous avons obtenu une correspondance optimale et une réduction maximale du bruit. SIT dispose d'une gamme complète de poulies FALCON GTR® conçues pour être assemblées avec les moyeux amovibles SER-SIT®.

Pour le montage avec moyeux amovibles SER-SIT®

Matière: acier / fonte / fonte GS

Finition : phosphatation au manganèse noir.

Pas :

- 8M
- 14M



Exécutions spéciales

Sur demande, SIT est capable de concevoir et fabriquer tout type de poulie selon les exigences du client. Pour une vitesse périphérique supérieure à 33 m / s, il est fortement recommandé d'utiliser l'acier comme matériau de construction.

$$\text{Vitesse périphérique [m/s]} = \frac{\text{diamètre de la poulie [mm]} \times \text{tr/mn}}{19100}$$

Afin de réduire le poids, les poulies peuvent être fabriquées à partir d'alliages. Dans ce cas, leur durée de vie sera réduite, car le revêtement de courroies en nylon a un effet légèrement abrasif. Cet inconvénient peut être évité par un chromage de la denture de la poulie.

Flasques

Les courroies dentées, lorsqu'elles sont en mouvement, se déplacent légèrement latéralement. Il est donc nécessaire d'utiliser au moins une poulie à flasques pour empêcher la courroie de sortir de la poulie.

Habituellement, afin de réduire les coûts, la poulie à flasques est celle de plus petit diamètre.

Cependant, lorsque la distance des axes est supérieure à 8 fois le diamètre de la petite poulie, ou lorsque la transmission s'effectue par des arbres disposés non horizontalement, les deux poulies doivent avoir des flasques.

TOLÉRANCES

Tolérances du diamètre de la poulie

Diamètre externe [mm]	Tolérances [mm]
jusqu'à 25,4	-0,00 +0,05
de 25,5 à 50,8	-0,00 +0,08
de 50,9 à 101,6	-0,00 +0,10
de 101,7 à 177,8	-0,00 +0,13
de 177,9 à 304,8	-0,00 +0,15
de 304,9 à 508,0	-0,00 +0,18
plus de 508,1	-0,00 +0,25

Tolérance d'excentration maxi entre l'alésage et le diamètre extérieur

Diamètre externe [mm]	Tolérances [mm]
jusqu'à 200	0,13
plus de 200	Ajoutez 0,0005 pour tout diamètre supérieur à 200 mm

Oscillation latérale ou voilage

Largeur de la poulie	Tolérances
par 100 mm	0,1 mm sans dépasser la tolérance de diamètre extérieur

Revêtement de protection

Toutes les poulies (acier et fonte) sont traitées avec un procédé de phosphatation au manganèse noir qui donne une plus grande résistance contre les agents oxydants. Ce traitement ne modifie pas le profil ou les dimensions des poulies.

Sur demande, SIT peut fournir une large gamme de revêtements spéciaux, liés aux besoins ou à des conditions environnementales critiques.

Note

En raison de l'amélioration constante de nos produits, les données techniques des poulies peuvent faire l'objet de modifications.

Dimensions des poulies dentées FALCON GTR - moyeu amovible SER-SIT® Types 8M - 14M



Désignation	PBG 34 G 8M 36
Poulies FALCON GTR - moyeu amovible	
Nombre de dents	
Pas	
Largeur de la courroie en mm	

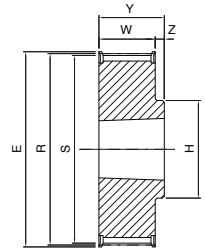

2

PBG ...G8M 12

8M

Code	Nb de dents	Type	Moyeu amovible SER-SIT®	E [mm]	R [mm]	S [mm]	U [mm]	H [mm]	d [mm]	W [mm]	Y [mm]	Z [mm]	Matière
PBG 22G8M12	22	6	1008	62,0	56,02	54,42	-	-	-	22,0	22,0	-	fonte
PBG 24G8M12	24	6	1108	67,0	61,12	59,52	-	-	-	22,0	22,0	-	
PBG 25G8M12	25	6	1108	67,0	63,66	62,06	-	-	-	22,0	22,0	-	
PBG 26G8M12	26	6	1108	73,0	66,21	64,61	-	-	-	22,0	22,0	-	
PBG 27G8M12	27	6	1108	73,0	68,75	67,15	-	-	-	22,0	22,0	-	
PBG 28G8M12	28	6	1108	77,0	71,30	69,70	-	-	-	22,0	22,0	-	
PBG 30G8M12	30	6	1108	84,0	76,39	74,79	-	-	-	22,0	22,0	-	
PBG 31G8M12	31	6	1108	84,0	78,94	77,34	-	-	-	22,0	22,0	-	
PBG 32G8M12	32	2	1210	88,0	81,49	79,89	-	66,0	-	20,0	25,0	5,0	acier
PBG 33G8M12	33	2	1610	94,0	84,03	82,43	-	72,0	-	20,0	25,0	5,0	
PBG 34G8M12	34	2	1610	94,0	86,58	84,98	-	72,0	-	20,0	25,0	5,0	
PBG 35G8M12	35	2	1610	94,0	89,13	87,53	-	72,0	-	20,0	25,0	5,0	
PBG 36G8M12	36	2	1610	98,0	91,67	90,07	-	75,0	-	20,0	25,0	5,0	
PBG 37G8M12	37	2	1610	100,0	94,22	92,62	-	77,0	-	20,0	25,0	5,0	
PBG 38G8M12	38	2	1610	104,0	96,77	95,17	-	82,0	-	20,0	25,0	5,0	
PBG 40G8M12	40	2	1610	108,0	101,86	100,26	-	89,0	-	20,0	25,0	5,0	
PBG 41G8M12	41	2	1610	111,0	104,41	102,81	-	89,0	-	20,0	25,0	5,0	fonte
PBG 42G8M12	42	2	1610	113,0	106,95	105,35	-	91,0	-	20,0	25,0	5,0	
PBG 44G8M12	44	2	2012	121,0	112,05	110,45	-	104,0	-	20,0	32,0	12,0	
PBG 45G8M12	45	2	2012	121,0	114,59	112,99	-	104,0	-	20,0	32,0	12,0	
PBG 48G8M12	48	2	2012	129,0	122,23	120,63	-	105,0	-	20,0	32,0	12,0	
PBG 50G8M12	50	2	2012	131,0	127,32	125,72	-	105,0	-	20,0	32,0	12,0	
PBG 53G8M12	53	2	2012	142,0	134,96	133,36	-	105,0	-	20,0	32,0	12,0	
PBG 56G8M12	56	2	2012	149,0	142,60	141,00	-	105,0	-	20,0	32,0	12,0	
PBG 60G8M12	60	2	2012	158,0	152,79	151,19	-	110,0	-	20,0	32,0	12,0	
PBG 64G8M12	64	6	2012	168,0	162,97	161,37	140,0	110,0	9,0	20,0	32,0	12,0	
PBG 67G8M12	67	6	2012	175,0	170,6	169,00	147,0	110,0	9,0	20,0	32,0	12,0	
PBG 72G8M12	72	6	2012	191,0	183,35	181,75	158,0	110,0	9,0	20,0	32,0	12,0	
PBG 75G8M12	75	6	2012	202,0	190,99	189,39	164,0	110,0	9,0	20,0	32,0	12,0	
PBG 80G8M12	80	6	2012	216,0	203,72	202,12	178,0	110,0	9,0	20,0	32,0	12,0	
PBG 90G8M12	90	9A	2012	-	229,18	227,58	204,0	110,0	9,0	20,0	32,0	12,0	

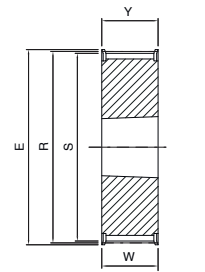

6

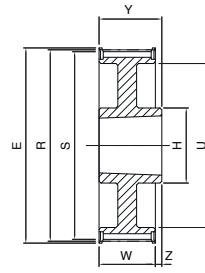

9

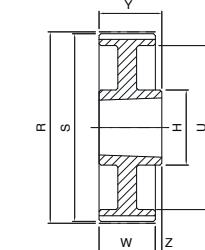

9A

Dimensions des poulies dentées FALCON GTR - moyeu amovible SER-SIT®



PBG ...G8M 21

8M

Code	Nb de dents	Type	Moyeu amovible SER-SIT®	E [mm]	R [mm]	S [mm]	U [mm]	H [mm]	d [mm]	W [mm]	Y [mm]	Z [mm]	Matière
PBG 22G8M21	22	4	1008	62,0	56,02	54,42	38,0	-	-	30,0	22,0	8,0	fonte
PBG 24G8M21	24	4	1108	67,0	61,12	59,52	42,0	-	-	30,0	22,0	8,0	
PBG 25G8M21	25	4	1108	67,0	63,66	62,06	45,0	-	-	30,0	22,0	8,0	
PBG 26G8M21	26	4	1108	73,0	66,21	64,61	45,0	-	-	30,0	22,0	8,0	
PBG 27G8M21	27	4	1108	73,0	68,75	67,15	45,0	-	-	30,0	22,0	8,0	
PBG 28G8M21	28	4	1108	77,0	71,30	69,70	52,0	-	-	30,0	22,0	8,0	
PBG 30G8M21	30	4	1610	84,0	76,39	74,79	58,0	-	-	30,0	25,0	5,0	acier
PBG 31G8M21	31	4	1610	84,0	78,94	77,34	58,0	-	-	30,0	25,0	5,0	
PBG 32G8M21	32	4	1610	88,0	81,49	79,89	63,0	-	-	30,0	25,0	5,0	
PBG 33G8M21	33	4	1610	88,0	84,04	82,44	63,0	-	-	30,0	25,0	5,0	
PBG 34G8M21	34	4	1610	94,0	86,58	84,98	68,0	-	-	30,0	25,0	5,0	
PBG 35G8M21	35	4	1610	94,0	89,13	87,53	68,0	-	-	30,0	25,0	5,0	
PBG 36G8M21	36	4	1610	98,0	91,67	90,07	73,0	-	-	30,0	25,0	5,0	fonte
PBG 37G8M21	37	4	1610	100,0	94,22	92,62	75,0	-	-	30,0	25,0	5,0	
PBG 38G8M21	38	4	1610	104,0	96,77	95,17	78,0	-	-	30,0	25,0	5,0	
PBG 40G8M21	40	4	1610	108,0	101,86	100,26	83,0	-	-	30,0	25,0	5,0	
PBG 41G8M21	41	4	1610	108,0	104,41	102,81	83,0	-	-	30,0	25,0	5,0	
PBG 42G8M21	42	4	1610	111,0	106,70	105,10	86,0	-	-	30,0	25,0	5,0	
PBG 44G8M21	44	1	2012	121,0	112,05	110,45	-	104,0	-	30,0	32,0	1,0	fonte
PBG 45G8M21	45	1	2012	121,0	114,59	112,99	-	104,0	-	30,0	32,0	1,0	
PBG 48G8M21	48	1	2012	129,0	122,23	120,63	-	105,0	-	30,0	32,0	1,0	
PBG 50G8M21	50	1	2012	131,0	127,32	125,72	-	105,0	-	30,0	32,0	1,0	
PBG 53G8M21	53	1	2012	142,0	134,96	133,36	-	120,0	-	30,0	32,0	1,0	
PBG 56G8M21	56	1	2012	149,0	142,60	141,00	-	105,0	-	30,0	32,0	1,0	
PBG 60G8M21	60	1	2517	158,0	152,79	151,19	-	110,0	-	30,0	45,0	7,5	
PBG 64G8M21	64	11	2517	168,0	162,97	161,37	138,0	120,0	10,0	30,0	45,0	7,5	
PBG 67G8M21	67	11	2517	175,0	170,60	169,00	145,0	120,0	10,0	30,0	45,0	7,5	
PBG 72G8M21	72	11	2517	191,0	183,35	181,75	158,0	120,0	10,0	30,0	45,0	7,5	
PBG 75G8M21	75	11	2517	202,0	190,99	189,39	165,0	120,0	10,0	30,0	45,0	7,5	
PBG 80G8M21	80	11	3020	216,0	203,72	202,12	178,0	160,0	10,0	30,0	51,0	10,5	
PBG 90G8M21	90	11A	3020	-	229,18	227,58	204,0	160,0	10,0	30,0	51,0	10,5	
PBG 112G8M21	112	11B	3020	-	285,21	283,61	260,0	160,0	20,0	30,0	51,0	10,5	
PBG 140G8M21	140	11B	3020	-	356,51	354,91	331,0	160,0	20,0	30,0	51,0	10,5	
PBG 144G8M21	144	11B	3020	-	366,69	365,09	341,0	160,0	20,0	30,0	51,0	10,5	

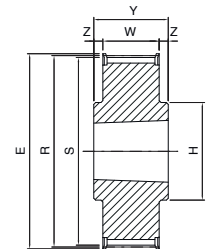

1

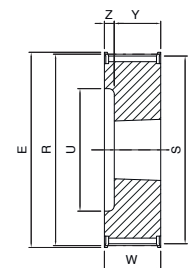

4

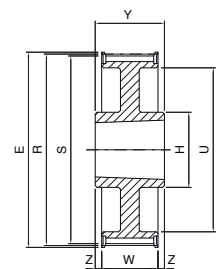

11

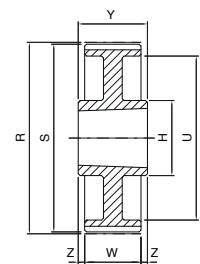

11A

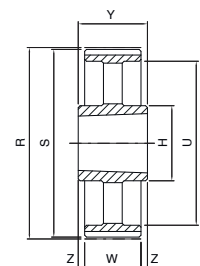

11B

Dimensions des poulies dentées FALCON GTR - moyeu amovible SER-SIT®



PBG ...G8M 36

8M

Code	Nb de dents	Type	Moyeu amovible SER-SIT®	E [mm]	R [mm]	S [mm]	U [mm]	H [mm]	d [mm]	W [mm]	Y [mm]	Z [mm]	Matière
PG 25G8M36	25	4C	-	67,0	63,66	62,06	-	49,0	-	45,0	55,0	10,0	acier
PG 26G8M36	26	4C	-	73,0	66,21	64,61	-	49,0	-	45,0	55,0	10,0	
PG 27G8M36	27	4C	-	73,0	68,75	67,15	-	49,0	-	45,0	55,0	10,0	
PG 28G8M36	28	4C	-	77,0	71,30	69,70	-	49,0	-	45,0	55,0	10,0	
PBG 30G8M36	30	4	1615	84,0	76,39	74,79	58,0	-	-	45,0	38,0	7,0	
PBG 31G8M36	31	4	1615	84,0	78,94	77,34	58,0	-	-	45,0	38,0	7,0	
PBG 32G8M36	32	4	1615	88,0	81,49	79,89	60,0	-	-	45,0	38,0	7,0	
PBG 33G8M36	33	4	1615	88,0	84,03	82,43	60,0	-	-	45,0	38,0	7,0	
PBG 34G8M36	34	4	1615	94,0	86,58	84,98	66,0	-	-	45,0	38,0	7,0	
PBG 35G8M36	35	4	1615	94,0	89,13	87,53	66,0	-	-	45,0	38,0	7,0	
PBG 36G8M36	36	4	1615	98,0	91,67	90,07	68,0	-	-	45,0	38,0	7,0	
PBG 37G8M36	37	4	1615	100,0	94,22	92,62	70,0	-	-	45,0	38,0	7,0	
PBG 38G8M36	38	4	1615	104,0	96,77	95,17	75,0	-	-	45,0	38,0	7,0	
PBG 40G8M36	40	5	2012	108,0	101,86	100,26	80,0	-	-	45,0	32,0	6,5	
PBG 41G8M36	41	5	2012	108,0	104,41	102,81	80,0	-	-	45,0	32,0	6,5	
PBG 42G8M36	42	5	2012	111,0	106,95	105,35	80,0	-	-	45,0	32,0	6,5	
PBG 44G8M36	44	5	2012	121,0	112,05	110,45	90,0	-	-	45,0	32,0	6,5	
PBG 45G8M36	45	5	2012	121,0	114,59	112,99	90,0	-	-	45,0	32,0	6,5	
PBG 48G8M36	48	5	2012	129,0	122,23	120,63	98,0	-	-	45,0	32,0	6,5	
PBG 50G8M36	50	5	2012	131,0	127,32	125,72	103,0	-	-	45,0	32,0	6,5	
PBG 53G8M36	53	5	2012	142,0	134,96	133,36	114,0	-	-	45,0	32,0	6,5	
PBG 56G8M36	56	6	2517	149,0	142,60	141,00	-	-	-	45,0	45,0	-	
PBG 60G8M36	60	6	2517	158,0	152,79	151,19	-	-	-	45,0	45,0	-	
PBG 64G8M36	64	7	2517	168,0	162,97	161,37	138,0	120,0	12,0	45,0	45,0	-	
PBG 67G8M36	67	7	2517	175,0	170,60	169,00	145,0	120,0	12,0	45,0	45,0	-	
PBG 72G8M36	72	7	2517	191,0	183,35	181,75	158,0	120,0	12,0	45,0	45,0	-	
PBG 75G8M36	75	11	3020	202,0	190,99	189,39	165,0	160,0	12,0	45,0	51,0	3,0	
PBG 80G8M36	80	11	3020	216,0	203,72	202,12	178,0	160,0	12,0	45,0	51,0	3,0	
PBG 90G8M36	90	11A	3020	-	229,18	227,58	204,0	160,0	12,0	45,0	51,0	3,0	
PBG 112G8M36	112	11B	3020	-	285,21	283,61	260,0	160,0	20,0	45,0	51,0	3,0	
PBG 140G8M36	140	11B	3020	-	356,51	354,91	331,0	160,0	20,0	45,0	51,0	3,0	
PBG 144G8M36	144	11B	3020	-	366,69	365,09	341,0	160,0	20,0	45,0	51,0	3,0	
PBG 168G8M36	168	11B	3020	-	427,81	426,21	402,0	160,0	20,0	45,0	51,0	3,0	
PBG 192G8M36	192	11B	3020	-	488,92	487,32	462,0	160,0	20,0	45,0	51,0	3,0	

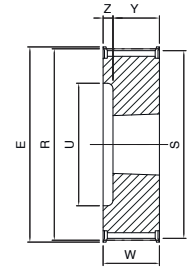

4

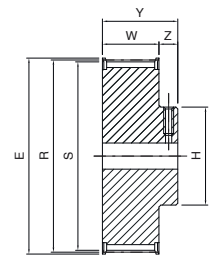

4C
Vis de réglage

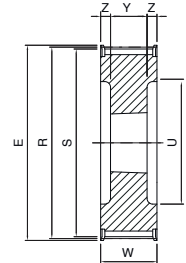

5

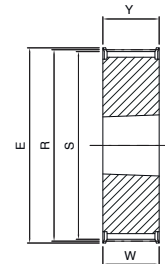

6

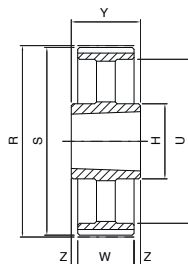

11B

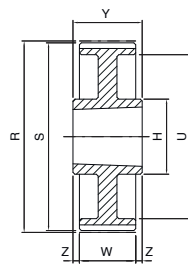

11A

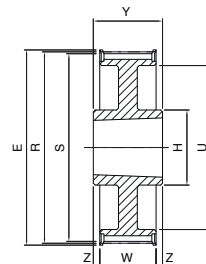

11

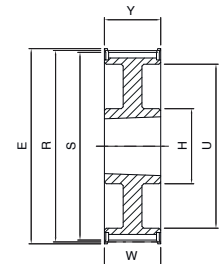

7

Dimensions des poulies dentées FALCON GTR - moyeu amovible SER-SIT®



PBG ...G8M 62

8M

Code	Nb de dents	Type	Moyeu amovible SER-SIT®	E [mm]	R [mm]	S [mm]	U [mm]	H [mm]	d [mm]	W [mm]	Y [mm]	Z [mm]	Matière
PBG 30G8M62	30	4	1615	84,0	76,39	74,79	58,0	-	-	72,0	38,0	34,0	acier
PBG 31G8M62	31	4	1615	88,0	78,94	77,34	60,0	-	-	72,0	38,0	34,0	
PBG 32G8M62	32	4	1615	88,0	81,49	79,89	60,0	-	-	72,0	38,0	34,0	
PBG 33G8M62	33	4	1615	90,0	84,04	82,44	62,0	-	-	72,0	38,0	34,0	
PBG 34G8M62	34	5	1615	94,0	86,58	84,98	66,0	-	-	72,0	38,0	17,0	fonte
PBG 35G8M62	35	5	1615	94,0	89,13	87,53	66,0	-	-	72,0	38,0	17,0	
PBG 36G8M62	36	5	1615	98,0	91,67	90,07	68,0	-	-	72,0	38,0	17,0	
PBG 37G8M62	37	5	1615	100,0	94,22	92,62	70,0	-	-	72,0	38,0	17,0	
PBG 38G8M62	38	5	1615	104,0	96,77	95,17	75,0	-	-	72,0	38,0	17,0	acier
PBG 40G8M62	40	5	2012	108,0	101,86	100,26	80,0	-	-	72,0	32,0	20,0	
PBG 41G8M62	41	5	2012	108,0	104,41	102,81	80,0	-	-	72,0	32,0	20,0	
PBG 42G8M62	42	5	2012	111,0	106,95	105,35	80,0	-	-	72,0	32,0	20,0	
PBG 44G8M62	44	5	2012	121,0	112,05	110,45	90,0	-	-	72,0	32,0	20,0	fonte
PBG 45G8M62	45	5	2012	121,0	114,59	112,99	92,0	-	-	72,0	32,0	20,0	
PBG 48G8M62	48	5	2517	129,0	122,23	120,63	100,0	-	-	72,0	45,0	13,5	acier
PBG 50G8M62	50	5	2517	131,0	127,32	125,72	105,0	-	-	72,0	45,0	13,5	
PBG 53G8M62	53	5	2517	142,0	134,96	133,36	116,0	-	-	72,0	45,0	13,5	
PBG 56G8M62	56	5	2517	149,0	142,60	141,00	120,0	-	-	72,0	45,0	13,5	
PBG 60G8M62	60	5	2517	158,0	152,79	151,19	128,0	-	-	72,0	45,0	13,5	fonte
PBG 64G8M62	64	5	2517	168,0	162,97	161,37	138,0	-	-	72,0	45,0	13,5	
PBG 67G8M62	67	5	3020	175,0	170,60	169,00	145,0	-	-	72,0	51,0	10,5	
PBG 72G8M62	72	5	3020	191,0	183,35	181,75	158,0	-	-	72,0	51,0	10,5	
PBG 75G8M62	75	5	3020	202,0	190,99	189,39	165,0	-	-	72,0	51,0	10,5	acier
PBG 80G8M62	80	8	3020	216,0	203,72	202,12	178,0	160,0	14,0	72,0	51,0	10,5	
PBG 90G8M62	90	8A	3020	-	229,18	227,58	204,0	160,0	14,0	72,0	51,0	10,5	
PBG 112G8M62	112	8B	3020	-	285,21	283,61	260,0	160,0	28,0	72,0	51,0	10,5	
PBG 140G8M62	140	11B	3030	-	356,51	354,91	331,0	146,0	28,0	72,0	76,0	2,0	fonte
PBG 144G8M62	144	11B	3030	-	366,69	365,09	341,0	146,0	28,0	72,0	76,0	2,0	
PBG 168G8M62	168	11B	3030	-	427,81	426,21	402,0	146,0	28,0	72,0	76,0	2,0	
PBG 192G8M62	192	11B	3030	-	488,92	487,32	462,0	146,0	28,0	72,0	76,0	2,0	

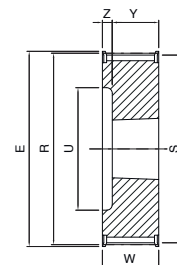

4

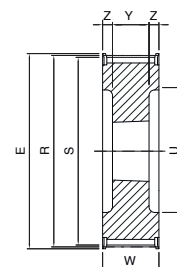

5

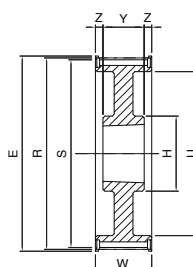

8

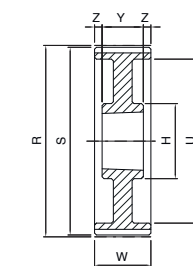

8A

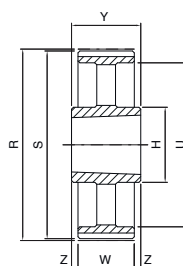

11B

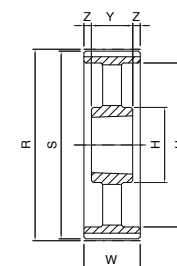

8B

Dimensions des poulies dentées FALCON GTR - moyeu amovible SER-SIT®



PBG ...G14M 20

14M

Code	Nb de dents	Type	Moyeu amovible SER-SIT®	E [mm]	R [mm]	S [mm]	U [mm]	H [mm]	d [mm]	W [mm]	Y [mm]	Z [mm]	Matière
PBG 28G14M20	28	3	2012	134,0	124,78	121,98	98,0	-	-	33,0	32,0	1,0	fonte
PBG 29G14M20	29	3	2012	134,0	129,23	126,43	100,0	-	-	33,0	32,0	1,0	
PBG 30G14M20	30	3	2012	142,0	133,69	130,89	100,0	-	-	33,0	32,0	1,0	
PBG 32G14M20	32	3	2012	150,0	142,60	139,80	104,0	-	-	33,0	32,0	1,0	
PBG 34G14M20	34	2	2517	158,0	151,52	148,72	-	125,0	-	33,0	45,0	12,0	
PBG 36G14M20	36	2	2517	166,0	160,43	157,63	-	125,0	-	33,0	45,0	12,0	
PBG 38G14M20	38	2	2517	177,0	169,34	166,54	-	125,0	-	33,0	45,0	12,0	
PBG 40G14M20	40	2	2517	186,0	178,25	175,45	-	125,0	-	33,0	45,0	12,0	
PBG 44G14M20	44	2	3020	209,0	196,08	193,28	-	160,0	-	33,0	51,0	18,0	
PBG 48G14M20	48	2	3020	216,0	213,90	211,11	-	160,0	-	33,0	51,0	18,0	
PBG 50G14M20	50	2	3020	232,0	222,82	220,02	-	160,0	-	33,0	51,0	18,0	
PBG 56G14M20	56	11	3020	261,0	249,55	246,76	207,0	160,0	10,0	33,0	51,0	9,0	
PBG 60G14M20	60	11	3020	274,0	267,38	264,58	224,0	160,0	10,0	33,0	51,0	9,0	
PBG 64G14M20	64	11	3020	288,0	285,21	282,41	243,0	160,0	10,0	33,0	51,0	9,0	
PBG 72G14M20	72	11A	3020	-	320,86	318,06	279,0	160,0	10,0	33,0	51,0	9,0	
PBG 80G14M20	80	11B	3020	-	356,51	353,71	314,0	160,0	18,0	33,0	51,0	9,0	
PBG 90G14M20	90	11B	3020	-	401,07	398,27	359,0	160,0	18,0	33,0	51,0	9,0	
PBG 112G14M20	112	11B	3020	-	499,11	496,31	457,0	160,0	18,0	33,0	51,0	9,0	
PBG 140G14M20	140	11B	3020	-	623,89	621,09	581,0	160,0	18,0	33,0	51,0	9,0	
PBG 144G14M20	144	11B	3020	-	641,71	638,92	600,0	160,0	18,0	33,0	51,0	9,0	
PBG 168G14M20	168	11B	3020	-	748,66	745,87	705,0	160,0	20,0	33,0	51,0	9,0	
PBG 192G14M20	192	11B	3535	-	855,62	852,82	812,0	178,0	20,0	33,0	89,0	28,0	
PBG 216G14M20	216	11B	3535	-	962,57	959,77	920,0	178,0	20,0	33,0	89,0	28,0	
PBG 264G14M20	264	11B	3535	-	1176,47	1173,67	1133,0	178,0	20,0	33,0	89,0	28,0	

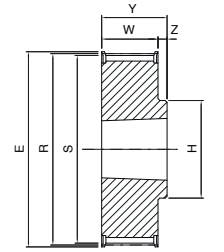

2

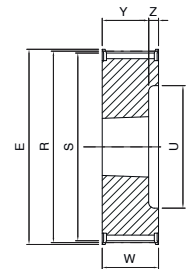

3

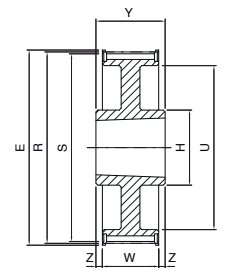

11

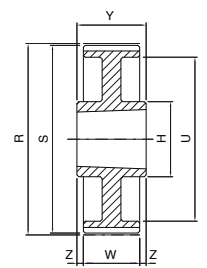

11A

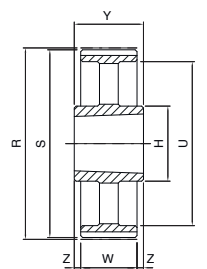

11B

Dimensions des poulies dentées FALCON GTR - moyeu amovible SER-SIT®



PBG ...G14M 37

14M

Code	Nb de dents	Type	Moyeu amovible SER-SIT®	E [mm]	R [mm]	S [mm]	U [mm]	H [mm]	d [mm]	W [mm]	Y [mm]	Z [mm]	Matière
PBG 28G14M37	28	5	2012	134,0	124,78	121,98	98,0	-	-	51,0	32,0	9,5	fonte
PBG 29G14M37	29	5	2012	134,0	129,23	126,43	100,0	-	-	51,0	32,0	9,5	
PBG 30G14M37	30	5	2012	142,0	133,69	130,89	100,0	-	-	51,0	32,0	9,5	
PBG 32G14M37	32	5	2012	150,0	142,60	139,80	104,0	-	-	51,0	32,0	9,5	
PBG 34G14M37	34	5	2517	158,0	151,52	148,72	110,0	-	-	51,0	45,0	3,0	
PBG 36G14M37	36	5	2517	166,0	160,43	157,63	120,0	-	-	51,0	45,0	3,0	
PBG 38G14M37	38	5	2517	177,0	169,34	166,54	130,0	-	-	51,0	45,0	3,0	
PBG 40G14M37	40	5	2517	186,0	178,25	175,45	138,0	-	-	51,0	45,0	3,0	
PBG 44G14M37	44	6	3020	209,0	196,08	193,28	-	-	-	51,0	51,0	-	
PBG 48G14M37	48	6	3020	216,0	213,90	211,11	-	-	-	51,0	51,0	-	
PBG 50G14M37	50	6	3020	232,0	222,82	220,02	-	-	-	51,0	51,0	-	
PBG 56G14M37	56	7	3020	261,0	249,55	246,76	207,0	160,0	12,0	51,0	51,0	-	
PBG 60G14M37	60	7	3020	274,0	267,38	264,58	224,0	160,0	12,0	51,0	51,0	-	
PBG 64G14M37	64	7	3020	288,0	285,21	282,41	243,0	160,0	12,0	51,0	51,0	-	
PBG 72G14M37	72	7A	3020	-	320,86	318,06	279,0	160,0	12,0	51,0	51,0	-	
PBG 80G14M37	80	7B	3020	-	356,51	353,71	314,0	160,0	18,0	51,0	51,0	-	
PBG 90G14M37	90	7B	3020	-	401,07	398,27	359,0	160,0	18,0	51,0	51,0	-	
PBG 112G14M37	112	11B	3535	-	499,11	496,31	457,0	178,0	31,0	51,0	89,0	19,0	
PBG 140G14M37	140	11B	3535	-	623,89	621,09	581,0	178,0	31,0	51,0	89,0	19,0	
PBG 144G14M37	144	11B	3535	-	641,71	638,92	600,0	178,0	31,0	51,0	89,0	19,0	
PBG 168G14M37	168	11B	3535	-	748,66	745,87	705,0	178,0	20,0	51,0	89,0	19,0	
PBG 192G14M37	192	11B	3535	-	855,62	852,82	812,0	178,0	20,0	51,0	89,0	19,0	
PBG 216G14M37	216	11B	4040	-	962,57	959,77	920,0	215,0	25,0	51,0	102,0	25,5	
PBG 264G14M37	264	11B	4040	-	1176,47	1173,67	1133,0	215,0	25,0	51,0	102,0	25,5	

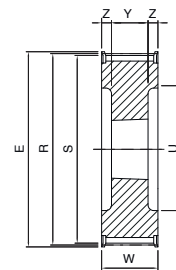

5

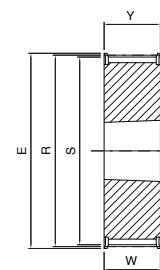

6

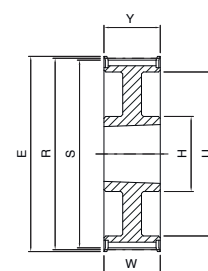

7

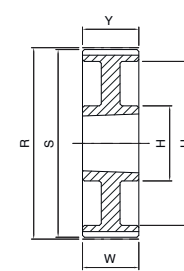

7A

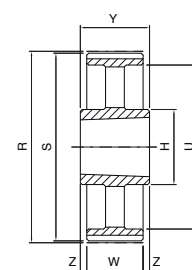

11B

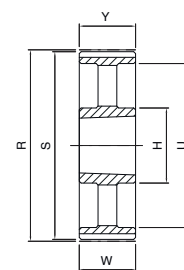

7B

Dimensions des poulies dentées FALCON GTR - moyeu amovible SER-SIT®



PBG ...G14M 68

14M

Code	Nb de dents	Type	Moyeu amovible SER-SIT®	E [mm]	R [mm]	S [mm]	U [mm]	H [mm]	d [mm]	W [mm]	Y [mm]	Z [mm]	Matière
PBG 28G14M68	28	5	2517	134,0	124,78	121,98	98,0	-	-	84,0	45,0	19,5	acier
PBG 29G14M68	29	5	2517	134,0	129,23	126,43	100,0	-	-	84,0	45,0	19,5	fonte
PBG 30G14M68	30	5	2517	142,0	133,69	130,89	100,0	-	-	84,0	45,0	19,5	
PBG 32G14M68*	32	5	2517	150,0	142,60	139,80	104,0	-	-	84,0	45,0	19,5	
PBG 34G14M68	34	4	3020	158,0	151,52	148,72	110,0	-	-	84,0	51,0	33,0	GS400
PBG 36G14M68	36	5	3020	166,0	160,43	157,63	120,0	-	-	84,0	51,0	16,5	fonte
PBG 38G14M68	38	5	3020	177,0	169,34	166,54	130,0	-	-	84,0	51,0	16,5	
PBG 40G14M68	40	5	3020	186,0	178,25	175,45	138,0	-	-	84,0	51,0	16,5	
PBG 44G14M68	44	5	3030	209,0	196,08	193,28	154,0	-	-	84,0	76,0	4,0	
PBG 48G14M68	48	5	3030	216,0	213,90	211,11	172,0	-	-	84,0	76,0	4,0	
PBG 50G14M68	50	1	3535	232,0	222,82	220,02	-	178,0	-	84,0	89,0	2,5	
PBG 56G14M68	56	1	3535	261,0	249,55	246,76	-	178,0	-	84,0	89,0	2,5	
PBG 60G14M68	60	11	3535	274,0	267,38	264,58	224,0	178,0	15,0	84,0	89,0	2,5	
PBG 64G14M68	64	11	3535	288,0	285,21	282,41	243,0	178,0	15,0	84,0	89,0	2,5	
PBG 72G14M68	72	11A	3535	-	320,86	318,06	279,0	178,0	16,0	84,0	89,0	2,5	
PBG 80G14M68	80	11B	3535	-	356,51	353,71	314,0	178,0	31,0	84,0	89,0	2,5	
PBG 90G14M68	90	11B	3535	-	401,07	398,27	359,0	178,0	31,0	84,0	89,0	2,5	
PBG 112G14M68	112	11B	3535	-	499,11	496,31	457,0	178,0	31,0	84,0	89,0	2,5	
PBG 140G14M68	140	11B	4040	-	623,89	621,09	581,0	215,0	36,0	84,0	102,0	9,0	
PBG 144G14M68	144	11B	4040	-	641,71	638,92	600,0	215,0	36,0	84,0	102,0	9,0	
PBG 168G14M68	168	11B	4040	-	748,66	745,87	705,0	215,0	25,0	84,0	102,0	9,0	
PBG 192G14M68	192	11B	4040	-	855,62	852,82	812,0	215,0	25,0	84,0	102,0	9,0	
PBG 216G14M68	216	11B	5050	-	962,57	959,77	920,0	267,0	25,0	84,0	127,0	21,5	
PBG 264G14M68	264	11B	5050	-	1176,47	1173,67	1133,0	267,0	25,0	84,0	127,0	21,5	

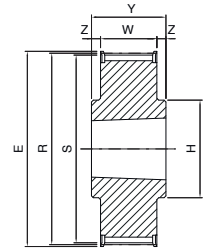

1

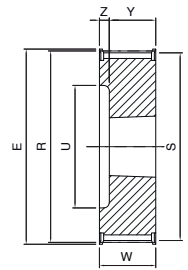

4

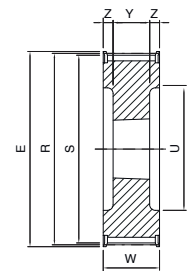

5

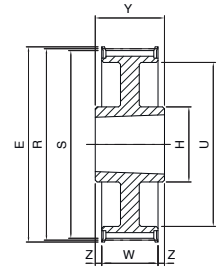

11

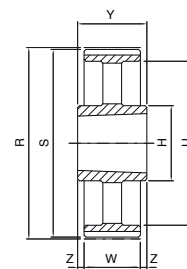

11B

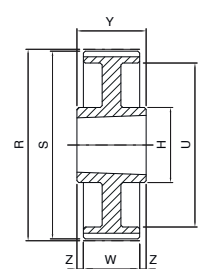

11A

Dimensions des poulies dentées FALCON GTR - moyeu amovible SER-SIT®



PBG ...G14M 90

14M

Code	Nb de dents	Type	Moyeu amovible SER-SIT®	E [mm]	R [mm]	S [mm]	U [mm]	H [mm]	d [mm]	W [mm]	Y [mm]	Z [mm]	Matière
PG 28G14M90	28	4C	-	134,0	124,78	121,98	-	100,0	-	106,0	121,0	15,0	fonte
PG 29G14M90	29	4C	-	134,0	129,23	126,43	-	100,0	-	106,0	121,0	15,0	
PG 30G14M90	30	4C	-	142,0	133,69	130,89	-	105,0	-	106,0	121,0	15,0	
PG 32G14M90*	32	4C	-	150,0	142,60	139,80	-	110,0	-	106,0	121,0	15,0	
PBG 34G14M90	34	4	3020	158,0	151,52	148,72	110,0	-	-	106,0	51,0	55,0	GS400
PBG 36G14M90	36	5	3020	166,0	160,43	157,63	120,0	-	-	106,0	51,0	27,5	fonte
PBG 38G14M90	38	5	3020	177,0	169,34	166,54	130,0	-	-	106,0	51,0	27,5	
PBG 40G14M90	40	5	3020	186,0	178,25	175,45	138,0	-	-	106,0	51,0	27,5	
PBG 44G14M90	44	5	3030	209,0	196,08	193,28	154,0	-	-	106,0	76,0	15,0	
PBG 48G14M90	48	5	3030	216,0	213,90	211,11	172,0	-	-	106,0	76,0	15,0	
PBG 50G14M90	50	5	3535	232,0	222,82	220,02	181,0	-	-	106,0	89,0	8,5	
PBG 56G14M90	56	5	3535	261,0	249,55	246,76	207,0	-	-	106,0	89,0	8,5	
PBG 60G14M90	60	5	3535	274,0	267,38	264,58	225,0	-	-	106,0	89,0	8,5	
PBG 64G14M90	64	8	3535	288,0	285,21	282,41	243,0	178,0	18	106,0	89,0	8,5	
PBG 72G14M90	72	8A	3535	-	320,86	318,06	279,0	178,0	18	106,0	89,0	8,5	
PBG 80G14M90	80	8B	3535	-	356,51	353,71	314,0	178,0	36	106,0	89,0	8,5	
PBG 90G14M90	90	8B	3535	-	401,07	398,27	359,0	178,0	36	106,0	89,0	8,5	
PBG 112G14M90	112	8B	4040	-	499,11	496,31	457,0	215,0	36	106,0	102,0	2,0	
PBG 140G14M90	140	8B	4040	-	623,89	621,09	582,0	215,0	36	106,0	102,0	2,0	
PBG 144G14M90	144	8B	4040	-	641,71	638,92	600,0	215,0	36	106,0	102,0	2,0	
PBG 168G14M90	168	11B	5050	-	748,66	745,87	705,0	267,0	25	106,0	127,0	10,5	
PBG 192G14M90	192	11B	5050	-	855,62	852,82	812,0	267,0	25	106,0	127,0	10,5	
PBG 216G14M90	216	11B	5050	-	962,57	959,77	920,0	267,0	25	106,0	127,0	10,5	
PBG 264G14M90	264	11B	6050	-	1176,47	1173,67	1133,0	395,0	25	106,0	127,0	10,5	

*= nouveau standard

GS400 = fonte GS

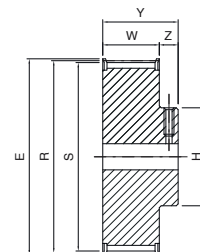

4C
Vis de serrage

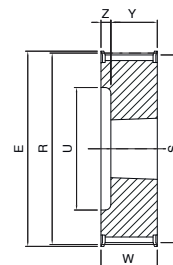

4

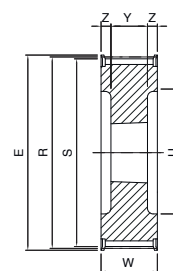

5

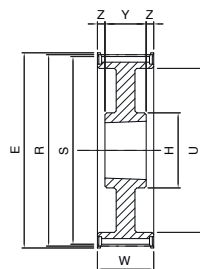

8

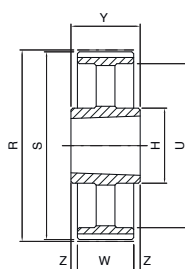

11B

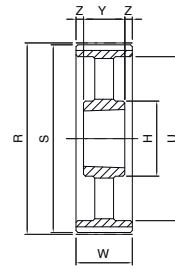

8B

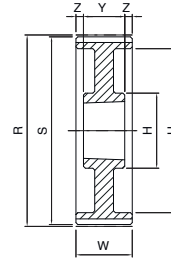

8A

Dimensions des poulies dentées FALCON GTR - moyeu amovible SER-SIT®



PBG ...G14M 125

14M

Code	Nb de dents	Type	Moyeu amovible SER-SIT®	E [mm]	R [mm]	S [mm]	U [mm]	H [mm]	d [mm]	W [mm]	Y [mm]	Z [mm]	Matière
PBG 38G14M125	38	4	3535	177,0	169,34	166,54	130,0	-	-	141,0	89,0	52,0	GS400
PBG 40G14M125	40	4	3535	186,0	178,25	175,45	138,0	-	-	141,0	89,0	52,0	
PBG 44G14M125	44	5	3535	209,0	196,08	193,28	154,0	-	-	141,0	89,0	26,0	
PBG 48G14M125	48	5	3535	216,0	213,90	211,11	172,0	-	-	141,0	89,0	26,0	
PBG 50G14M125	50	5	3535	232,0	222,82	220,02	180,0	-	-	141,0	89,0	26,0	
PBG 56G14M125	56	5	3535	261,0	249,55	246,76	207,0	-	-	141,0	89,0	26,0	fonte
PBG 60G14M125	60	5	4040	274,0	267,38	264,58	224,0	-	-	141,0	102,0	19,5	
PBG 64G14M125	64	5	4040	288,0	285,21	282,41	243,0	-	-	141,0	102,0	19,5	
PBG 72G14M125	72	8A	4040	-	320,86	318,06	279,0	215,0	21,0	141,0	102,0	19,5	
PBG 80G14M125	80	8A	4040	-	356,51	353,71	314,0	215,0	21,0	141,0	102,0	19,5	
PBG 90G14M125	90	8B	4040	-	401,07	398,27	359,0	215,0	41,0	141,0	102,0	19,5	
PBG 112G14M125	112	8B	5050	-	499,11	496,31	457,0	267,0	41,0	141,0	127,0	7,0	
PBG 140G14M125	140	8B	5050	-	623,89	621,09	581,0	267,0	41,0	141,0	127,0	7,0	
PBG 144G14M125	144	8B	5050	-	641,71	638,92	600,0	267,0	41,0	141,0	127,0	7,0	
PBG 168G14M125	168	8B	5050	-	748,66	745,87	705,0	267,0	40,0	141,0	127,0	7,0	
PBG 192G14M125	192	8B	6050	-	855,62	852,82	812,0	395,0	40,0	141,0	127,0	7,0	
PBG 216G14M125	216	8B	6050	-	962,57	959,77	920,0	395,0	40,0	141,0	127,0	7,0	
PBG 264G14M125	264	8B	6050	-	1176,47	1173,67	1133,0	395,0	40,0	141,0	127,0	7,0	

GS400 = fonte GS

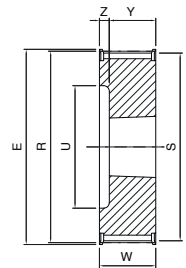

4

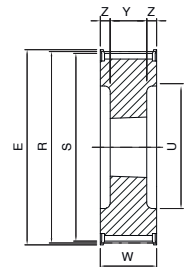

5

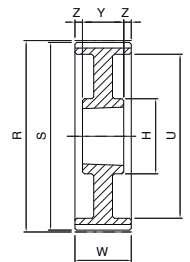

8A

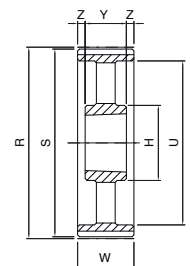

8B

Les poulies SIT EAGLE®, fabriquées avec des équipements innovants de haute technologie, ont été spécifiquement conçues pour s'adapter aux courroies SILENT SYNC®. Cette combinaison, grâce à l'engagement continu et progressif de la courroie avec les poulies, est la meilleure solution existante aujourd'hui en termes de réductions du bruit, de l'usure et d'amortissement des vibrations. La transmission EAGLE® est la seule qui garantit l'auto-alignement, même dans des conditions de charge élevée ou une vitesse périphérique extrême. Pour cette raison, les poulies EAGLE® n'ont pas besoin de flasques. Il en résulte des entraînements plus compacts. Les poulies standard EAGLE® sont statiquement équilibrées.

Moyeu plein

Matière: acier /fonte GS/fonte grise/aluminium
Finition: phosphatation au manganèse noir.

Pas :

- 5M
- 8M
- 10M
- 14M



Pour le montage avec moyeux amovibles SER-SIT®

Matière : acier /fonte GS/fonte grise
Finition : phosphatation au manganèse noir.

Pas :

- 14M



Exécutions spéciales

Sur demande, SIT est capable de concevoir et fabriquer à un type de poulie selon les exigences du client. Pour une vitesse périphérique supérieure à 33 m / s, il est fortement recommandé d'utiliser l'acier comme matière de construction.

Dans le cas d'une exécution en aluminium, il est possible de réduire l'abrasion de la poulie due au revêtement en nylon, grâce à un revêtement épais anodisé des dents de la poulie (sur demande).

$$\text{Vitesse périphérique [m/s]} = \frac{\text{diamètre de la poulie [mm]} \times \text{tr/mm}}{19100}$$

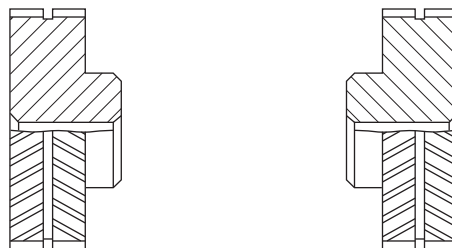

Attention: pour les exécutions non standard, il est important d'indiquer l'orientation des dents selon la position du moyeu (comme les images ci-dessus).

TOLÉRANCES

Tolérances du diamètre de la poulie

Diamètre externe [mm]	Tolérances [mm]
jusqu'à 101,6	-0,00 +0,13
de 101,7 à 177,8	-0,00 +0,13
de 177,9 à 304,8	-0,00 +0,15
de 304,9 à 508,0	-0,00 +0,18
de 508,1 à 750,0	-0,00 +0,20

Tolérance d'excentration maxi entre l'alésage et le diamètre extérieur

Diamètre externe [mm]	Tolérances [mm]
jusqu'à 101,6	0,13
de 101,7 à 177,8	0,13
de 177,9 à 304,8	0,15
de 304,9 à 508,0	0,20
de 508,1 à 750,0	0,30

Oscillation latérale ou voilage

Largeur de la poulie	Tolérances
par 100 mm	0,1 mm sans dépasser la tolérance de diamètre extérieur

Revêtement de protection

Toutes les poulies (acier et fonte) sont traitées avec un procédé de phosphatation au manganèse noir qui donne une plus grande résistance contre les agents oxydants. Ce traitement ne modifie pas le profil ou les dimensions des poulies.

Sur demande, SIT peut fournir une large gamme de revêtements spéciaux, liés aux besoins ou à des conditions environnementales critiques.

Note

En raison de l'amélioration constante de nos produits, les données techniques des poulies peuvent faire l'objet de modifications.

Dimensions des poulies dentées EAGLE - moyeu plein

Types 8M - 14M



Désignation	PE	Y	32S	MPB
Poulies EAGLE- moyeu plein				
Largeur de la courroie				
Nombre de dents				
Moyeu plein				

Type "Yellow" Y - Largeur de la courroie W = 16 mm

8M

Code	Nb de dents	Type	R [mm]	S [mm]	U [mm]	H [mm]	d [mm]	W [mm]	Y [mm]	Z [mm]	Alésage max [mm]	Matière
PEY-18S-MPB	18	1	45,84	44,47	-	38,4	12,7	17,0	27,0	10,0	26,0	acier
PEY-20S-MPB	20	1	50,93	49,56	-	40,7	12,7	17,0	29,0	12,0	27,0	
PEY-22S-MPB	22	1	56,02	54,65	-	45,9	12,7	17,0	29,0	12,0	31,0	
PEY-24S-MPB	24	1	61,12	59,75	-	51,0	12,7	17,0	33,0	16,0	34,0	
PEY-25S-MPB	25	1	63,66	62,29	-	53,5	12,7	17,0	33,0	16,0	36,0	
PEY-26S-MPB	26	1	66,21	64,84	-	57,8	12,7	17,0	33,0	16,0	39,0	
PEY-28S-MPB	28	1	71,30	69,93	-	61,0	12,7	17,0	33,0	16,0	41,0	
PEY-30S-MPB	30	1	76,40	75,03	-	67,0	12,7	17,0	33,0	16,0	45,0	
PEY-32S-MPB	32	1	81,49	80,12	-	72,0	12,7	17,0	33,0	16,0	48,0	
PEY-34S-MPB	34	1	86,58	85,21	-	77,0	12,7	17,0	33,0	16,0	51,0	
PEY-36S-MPB	36	1	91,68	90,30	-	82,0	12,7	17,0	33,0	16,0	55,0	
PEY-38S-MPB	38	1	96,77	95,40	-	87,0	12,7	17,0	33,0	16,0	58,0	
PEY-40S-MPB	40	1	101,86	100,49	-	92,0	12,7	17,0	33,0	16,0	62,0	
PEY-44S-MPB	44	1	112,05	110,68	-	102,0	12,7	17,0	33,0	16,0	68,0	
PEY-45S-MPB	45	1	114,59	113,22	-	105,0	12,7	17,0	33,0	16,0	70,0	
PEY-48S-MPB	48	1	122,23	120,86	-	112,0	12,7	17,0	33,0	16,0	75,0	
PEY-50S-MPB	50	1	127,33	125,96	-	118,0	12,7	17,0	33,0	16,0	79,0	
PEY-52S-MPB	52	1	132,42	131,05	-	123,0	12,7	17,0	33,0	16,0	82,0	
PEY-56S-MPB	56	1	142,61	141,24	-	133,0	12,7	17,0	33,0	16,0	89,0	
PEY-60S-MPB	60	1	152,79	151,42	-	143,0	12,7	17,0	33,0	16,0	96,0	
PEY-63S-MPB	63	2	160,43	159,06	139,0	110,0	12,7	17,0	33,0	16,0	73,0	GS400
PEY-64S-MPB	64	2	162,98	161,61	142,0	110,0	12,7	17,0	33,0	16,0	74,0	
PEY-68S-MPB	68	2	173,17	171,79	152,0	110,0	12,7	17,0	33,0	16,0	74,0	
PEY-72S-MPB	72	2	183,35	181,98	162,0	110,0	12,7	17,0	33,0	16,0	74,0	
PEY-75S-MPB	75	2	190,99	189,62	170,0	110,0	12,7	17,0	33,0	16,0	73,0	
PEY-76S-MPB	76	2	193,54	192,17	172,0	110,0	12,7	17,0	33,0	16,0	74,0	
PEY-80S-MPB	80	2	203,72	202,35	182,0	110,0	12,7	17,0	33,0	16,0	73,0	GG
PEY-90S-MPB	90	2	229,19	227,82	208,0	110,0	25,4	17,0	33,0	16,0	73,0	
PEY-112S-MPB	112	2	285,21	283,84	264,0	110,0	25,4	17,0	33,0	16,0	73,0	
PEY-140S-MPB	140	2	356,52	355,15	335,0	110,0	25,4	17,0	33,0	16,0	73,0	
PEY-180S-MPB	180	3	458,38	457,01	433,0	150,0	25,4	17,0	33,0	16,0	100,0	
PEY-224S-MPB	224	3	570,43	569,06	545,0	150,0	25,4	17,0	33,0	16,0	100,0	

GS400 = fonte GS - GG = fonte grise

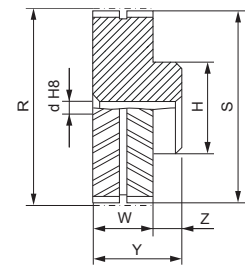

1

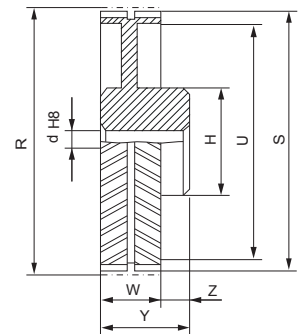

2

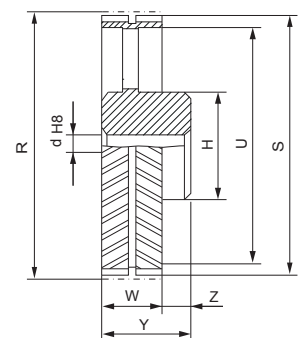

3

Dimensions des poulies dentées EAGLE - moyeu plein



Type "White" W - Largeur de la courroie W = 32 mm

8M

Code	Nb de dents	Type	R [mm]	S [mm]	U [mm]	H [mm]	d [mm]	W [mm]	Y [mm]	Z [mm]	Alésage max [mm]	Matière
PEW-18S-MPB	18	1	45,84	44,47	-	38,4	12,7	33,0	43,0	10,0	26,0	acier
PEW-20S-MPB	20	1	50,93	49,56	-	40,7	12,7	33,0	45,0	12,0	27,0	
PEW-22S-MPB	22	1	56,02	54,65	-	45,9	12,7	33,0	45,0	12,0	31,0	
PEW-24S-MPB	24	1	61,12	59,75	-	51,0	12,7	33,0	49,0	16,0	34,0	
PEW-25S-MPB	25	1	63,66	62,29	-	53,5	12,7	33,0	49,0	16,0	36,0	
PEW-26S-MPB	26	1	66,21	64,84	-	57,8	12,7	33,0	49,0	16,0	39,0	
PEW-28S-MPB	28	1	71,30	69,93	-	62,0	12,7	33,0	49,0	16,0	41,0	
PEW-30S-MPB	30	1	76,40	75,03	-	67,0	12,7	33,0	49,0	16,0	45,0	
PEW-32S-MPB	32	1	81,49	80,12	-	72,0	12,7	33,0	49,0	16,0	48,0	
PEW-34S-MPB	34	1	86,58	85,21	-	77,0	12,7	33,0	49,0	16,0	51,0	
PEW-36S-MPB	36	1	91,68	90,30	-	82,0	12,7	33,0	49,0	16,0	55,0	
PEW-38S-MPB	38	1	96,77	95,40	-	87,0	12,7	33,0	49,0	16,0	58,0	
PEW-40S-MPB	40	1	101,86	100,49	-	92,0	12,7	33,0	49,0	16,0	62,0	
PEW-44S-MPB	44	1	112,05	110,68	-	102,0	12,7	33,0	49,0	16,0	68,0	
PEW-45S-MPB	45	1	114,59	113,22	-	105,0	12,7	33,0	49,0	16,0	70,0	
PEW-48S-MPB	48	1	122,23	120,86	-	112,0	12,7	33,0	49,0	16,0	75,0	
PEW-50S-MPB	50	1	127,33	125,96	-	118,0	12,7	33,0	49,0	16,0	79,0	
PEW-52S-MPB	52	1	132,42	131,05	-	123,0	12,7	33,0	49,0	16,0	82,0	
PEW-56S-MPB	56	1	142,61	141,24	-	133,0	12,7	33,0	49,0	16,0	89,0	
PEW-60S-MPB	60	1	152,79	151,42	-	143,0	12,7	33,0	49,0	16,0	96,0	
PEW-63S-MPB	63	1	160,43	159,06	-	151,0	12,7	33,0	49,0	16,0	101,0	
PEW-64S-MPB	64	1	162,98	161,61	-	153,0	12,7	33,0	49,0	16,0	102,0	
PEW-68S-MPB	68	2	173,17	171,79	152,0	120,0	25,4	33,0	49,0	16,0	80,0	GS400
PEW-72S-MPB	72	2	183,35	181,98	162,0	120,0	25,4	33,0	49,0	16,0	80,0	
PEW-75S-MPB	75	2	190,99	189,62	170,0	120,0	25,4	33,0	49,0	16,0	80,0	
PEW-76S-MPB	76	2	193,54	192,17	172,0	120,0	25,4	33,0	49,0	16,0	80,0	
PEW-80S-MPB	80	2	203,72	202,35	182,0	120,0	25,4	33,0	49,0	16,0	80,0	
PEW-90S-MPB	90	2	229,19	227,82	208,0	120,0	25,4	33,0	49,0	16,0	80,0	
PEW-112S-MPB	112	2	285,21	283,84	264,0	120,0	25,4	33,0	49,0	16,0	100,0	GG
PEW-140S-MPB	140	2	356,52	355,15	335,0	150,0	25,4	33,0	49,0	16,0	100,0	
PEW-180S-MPB	180	3	458,38	457,00	433,0	150,0	25,4	33,0	49,0	16,0	100,0	
PEW-224S-MPB	224	3	570,43	569,04	545,0	150,0	25,4	33,0	49,0	16,0	100,0	

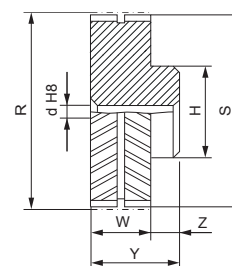

1

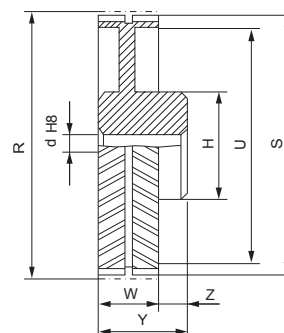

2

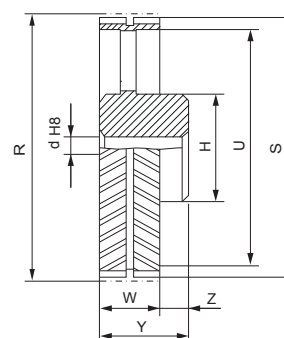

3

GS400 = fonte GS - GG = fonte grise

Dimensions des poulies dentées EAGLE - moyeu plein



Type "Purple" P - Largeur de la courroie W = 64 mm

8M

POULIES DENTÉES - PE

Code	Nb de dents	Type	R [mm]	S [mm]	U [mm]	H [mm]	d [mm]	W [mm]	Y [mm]	Z [mm]	Alésage max [mm]	Matière	
PEP-18S-MPB	18	1	45,84	44,47	-	38,4	12,7	65,0	85,0	20,0	26,0	acier	
PEP-20S-MPB	20	1	50,93	49,55	-	40,7	12,7	65,0	85,0	20,0	27,0		
PEP-22S-MPB	22	1	56,02	54,64	-	45,9	12,7	65,0	85,0	20,0	31,0		
PEP-24S-MPB	24	1	61,12	59,74	-	51,0	12,7	65,0	85,0	20,0	34,0		
PE P-25S-MPB	25	1	63,66	62,28	-	53,5	12,7	65,0	85,0	20,0	36,0		
PEP-26S-MPB	26	1	66,21	64,83	-	57,8	12,7	65,0	85,0	20,0	39,0		
PEP-28S-MPB	28	1	71,30	69,92	-	62,0	12,7	65,0	85,0	20,0	41,0		
PEP-30S-MPB	30	1	76,39	75,01	-	67,0	12,7	65,0	85,0	20,0	45,0		
PEP-32S-MPB	32	1	81,49	80,11	-	72,0	12,7	65,0	85,0	20,0	48,0		
PEP-34S-MPB	34	1	86,58	85,20	-	77,0	12,7	65,0	85,0	20,0	51,0		
PEP-36S-MPB	36	1	91,67	90,29	-	82,0	12,7	65,0	85,0	20,0	55,0		
PEP-38S-MPB	38	1	96,77	95,39	-	87,0	12,7	65,0	85,0	20,0	58,0		
PEP-40S-MPB	40	1	101,86	100,48	-	92,0	12,7	65,0	85,0	20,0	62,0		
PEP-44S-MPB	44	1	112,05	110,67	-	102,0	12,7	65,0	85,0	20,0	68,0		
PEP-45S-MPB	45	1	114,59	113,21	-	105,0	12,7	65,0	85,0	20,0	70,0		
PEP-48S-MPB	48	1	122,23	120,85	-	112,0	25,4	65,0	85,0	20,0	75,0		
PEP-50S-MPB	50	1	127,32	125,94	-	118,0	25,4	65,0	85,0	20,0	79,0		
PEP-52S-MPB	52	1	132,42	131,04	-	123,0	25,4	65,0	85,0	20,0	82,0		
PEP-56S-MPB	56	1	142,60	141,22	-	133,0	25,4	65,0	85,0	20,0	89,0		
PEP-60S-MPB	60	1	152,79	151,41	-	143,0	25,4	65,0	85,0	20,0	96,0		
PEP-63S-MPB	63	1	160,43	159,05	-	151,0	25,4	65,0	85,0	20,0	101,0		
PEP-64S-MPB	64	1	162,98	161,60	-	153,0	25,4	65,0	85,0	20,0	102,0		
PEP-68S-MPB	68	2	173,17	171,79	152,0	120,0	25,4	65,0	85,0	20,0	80,0		GS400
PEP-72S-MPB	72	2	183,35	181,97	162,0	120,0	25,4	65,0	85,0	20,0	80,0		
PEP-75S-MPB	75	2	190,99	189,61	170,0	120,0	25,4	65,0	85,0	20,0	80,0		
PEP-76S-MPB	76	2	193,53	192,15	172,0	120,0	25,4	65,0	85,0	20,0	80,0		
PEP-80S-MPB	80	2	203,72	202,34	182,0	120,0	25,4	65,0	85,0	20,0	80,0		
PEP-90S-MPB	90	2	229,18	227,80	208,0	120,0	25,4	65,0	85,0	20,0	80,0		
PEP-112S-MPB	112	2	285,21	283,83	264,0	120,0	25,4	65,0	85,0	20,0	80,0	GG	
PEP-140S-MPB	140	2	356,51	355,14	335,0	150,0	25,4	65,0	85,0	20,0	100,0		
PEP-180S-MPB	180	3	458,37	457,00	433,0	150,0	25,4	65,0	85,0	20,0	100,0		
PEP-224S-MPB	224	3	570,41	569,04	545,0	150,0	25,4	65,0	85,0	20,0	100,0		

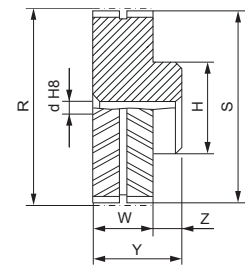

1

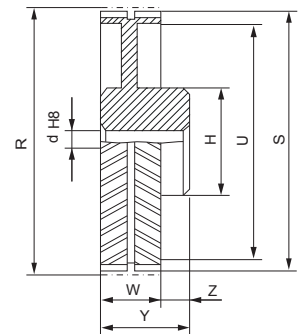

2

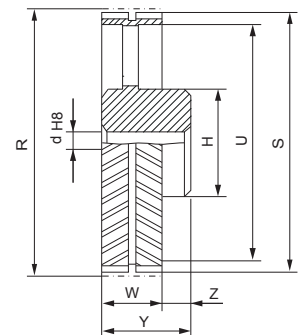

3

GS400 = fonte GS - GG = fonte grise

Dimensions des poulies dentées EAGLE - moyeu plein



Type "Blue" B - Largeur de la courroie W = 35 mm

14M

Code	Nb de dents	Type	R [mm]	S [mm]	U [mm]	H [mm]	d [mm]	W [mm]	Y [mm]	Z [mm]	Alésage max [mm]	Matière
PEB-28S-MPB	28	1	124,78	121,99	-	105,0	25,4	37,0	53,0	16,0	70,0	acier
PEB-30S-MPB	30	1	133,69	130,90	-	114,0	25,4	37,0	53,0	16,0	76,0	
PEB-32S-MPB	32	1	142,61	139,81	-	123,0	25,4	37,0	53,0	16,0	82,0	
PEB-34S-MPB	34	1	151,52	148,73	-	132,0	25,4	37,0	53,0	16,0	88,0	
PEB-36S-MPB	36	1	160,43	157,64	-	141,0	25,4	37,0	53,0	16,0	94,0	
PEB-38S-MPB	38	1	169,35	166,55	-	150,0	25,4	37,0	53,0	16,0	100,0	
PEB-40S-MPB	40	1	178,26	175,46	-	159,0	25,4	37,0	53,0	16,0	106,0	
PEB-43S-MPB	43	1	191,63	188,83	-	172,0	25,4	37,0	53,0	16,0	115,0	
PEB-45S-MPB	45	1	200,54	197,75	-	181,0	25,4	37,0	53,0	16,0	121,0	
PEB-48S-MPB	48	1	213,91	211,12	-	195,0	25,4	37,0	53,0	16,0	130,0	
PEB-50S-MPB	50	2	222,82	220,03	185,0	150,0	25,4	37,0	53,0	16,0	100,0	GS400
PEB-56S-MPB	56	2	249,56	246,77	212,0	150,0	25,4	37,0	53,0	16,0	100,0	
PEB-60S-MPB	60	2	267,39	264,59	230,0	150,0	25,4	37,0	53,0	16,0	100,0	
PEB-63S-MPB	63	2	280,76	277,96	243,0	150,0	25,4	37,0	53,0	16,0	100,0	
PEB-71S-MPB	71	2	316,41	313,62	279,0	150,0	25,4	37,0	53,0	16,0	100,0	
PEB-75S-MPB	75	2	334,24	331,44	296,0	150,0	25,4	37,0	53,0	16,0	100,0	
PEB-80S-MPB	80	2	356,52	353,72	319,0	150,0	25,4	37,0	53,0	16,0	100,0	GG
PEB-90S-MPB	90	2	401,08	398,29	358,0	150,0	25,4	37,0	53,0	16,0	100,0	
PEB-112S-MPB	112	3	499,12	496,33	456,0	150,0	25,4	37,0	53,0	16,0	100,0	
PEB-140S-MPB	140	3	623,91	621,11	581,0	150,0	25,4	37,0	53,0	16,0	100,0	
PEB-168S-MPB	168	3	748,69	745,89	706,0	150,0	25,4	37,0	53,0	16,0	100,0	

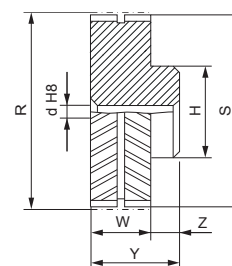

1

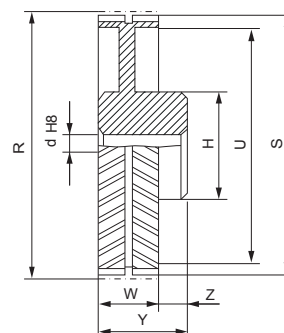

2

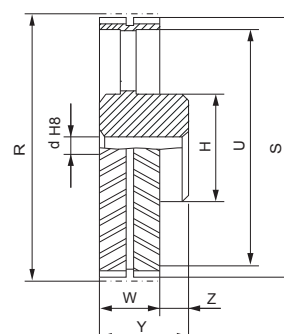

3

Type "Green" G - width W = 52,5 mm

14M

Code	Nb de dents	Type	R [mm]	S [mm]	U [mm]	H [mm]	d [mm]	W [mm]	Y [mm]	Z [mm]	Alésage max [mm]	Matière
PEG-28S-MPB	28	1	124,78	121,99	-	109,0	25,4	54,5	74,5	20,0	73,0	acier
PEG-30S-MPB	30	1	133,69	130,90	-	117,5	25,4	54,5	74,5	20,0	78,0	
PEG-32S-MPB	32	1	142,61	139,81	-	126,5	25,4	54,5	74,5	20,0	84,0	
PEG-34S-MPB	34	1	151,52	148,73	-	135,5	25,4	54,5	74,5	20,0	90,0	
PEG-36S-MPB	36	1	160,43	157,64	-	141,0	25,4	54,5	70,5	16,0	94,0	
PEG-38S-MPB	38	1	169,35	166,55	-	150,0	25,4	54,5	70,5	16,0	100,0	
PEG-40S-MPB	40	1	178,26	175,46	-	159,0	25,4	54,5	70,5	16,0	106,0	
PEG-43S-MPB	43	1	191,63	188,83	-	172,0	25,4	54,5	70,5	16,0	115,0	
PEG-45S-MPB	45	1	200,54	197,75	-	181,0	25,4	54,5	70,5	16,0	121,0	
PEG-48S-MPB	48	1	213,91	211,12	-	195,0	25,4	54,5	70,5	16,0	130,0	
PEG-50S-MPB	50	2	222,82	220,03	185,0	150,0	25,4	54,5	70,5	16,0	100,0	GS400
PEG-56S-MPB	56	2	249,56	246,77	212,0	150,0	25,4	54,5	70,5	16,0	100,0	
PEG-60S-MPB	60	2	267,39	264,59	230,0	150,0	25,4	54,5	70,5	16,0	100,0	
PEG-63S-MPB	63	2	280,76	277,96	243,0	150,0	25,4	54,5	70,5	16,0	100,0	
PEG-71S-MPB	71	2	316,41	313,62	279,0	150,0	25,4	54,5	70,5	16,0	100,0	
PEG-75S-MPB	75	2	334,24	331,44	296,0	150,0	25,4	54,5	70,5	16,0	100,0	
PEG-80S-MPB	80	2	356,52	353,72	319,0	150,0	25,4	54,5	70,5	16,0	100,0	GG
PEG-90S-MPB	90	2	401,08	398,29	358,0	180,0	25,4	54,5	70,5	16,0	120,0	
PEG-112S-MPB	112	3	499,12	496,33	456,0	180,0	25,4	54,5	70,5	16,0	120,0	
PEG-140S-MPB	140	3	623,91	621,11	581,0	200,0	25,4	54,5	70,5	16,0	133,0	
PEG-168S-MPB	168	3	748,69	745,89	706,0	200,0	25,4	54,5	70,5	16,0	133,0	

GS400 = fonte GS - GG = fonte grise

Dimensions des poulies dentées EAGLE - moyeu plein



Type "Orange" O - Largeur de la courroie W = 70 mm

14M

Code	Nb de dents	Type	R [mm]	S [mm]	U [mm]	H [mm]	d [mm]	W [mm]	Y [mm]	Z [mm]	Alésage max [mm]	Matière
PEO-28S-MPB	28	1	124,78	121,99	-	109,0	25,4	72,0	92,0	20,0	73,0	acier
PEO-30S-MPB	30	1	133,69	130,90	-	117,5	25,4	72,0	92,0	20,0	78,0	
PEO-32S-MPB	32	1	142,61	139,81	-	126,5	25,4	72,0	98,0	26,0	84,0	
PEO-34S-MPB	34	1	151,52	148,73	-	135,5	25,4	72,0	98,0	26,0	90,0	
PEO-36S-MPB	36	1	160,43	157,64	-	144,0	25,4	72,0	98,0	26,0	95,0	
PEO-38S-MPB	38	1	169,35	166,55	-	153,0	25,4	72,0	98,0	26,0	101,0	
PEO-40S-MPB	40	1	178,26	175,46	-	162,0	25,4	72,0	98,0	26,0	107,0	
PEO-43S-MPB	43	1	191,63	188,83	-	174,0	25,4	72,0	88,0	16,0	116,0	
PEO-45S-MPB	45	1	200,54	197,75	-	183,0	25,4	72,0	88,0	16,0	122,0	
PEO-48S-MPB	48	1	213,91	211,12	-	197,0	25,4	72,0	88,0	16,0	131,0	
PEO-50S-MPB	50	1	222,82	220,03	-	205,0	25,4	72,0	88,0	16,0	137,0	
PEO-56S-MPB	56	1	249,56	246,77	-	230,0	25,4	72,0	88,0	16,0	153,0	
PEO-60S-MPB	60	2	267,39	264,59	230,0	150,0	25,4	72,0	88,0	16,0	100,0	GS400
PEO-63S-MPB	63	2	280,76	277,96	243,0	150,0	25,4	72,0	88,0	16,0	100,0	
PEO-71S-MPB	71	2	316,41	313,62	279,0	150,0	25,4	72,0	88,0	16,0	100,0	
PEO-75S-MPB	75	2	334,24	331,44	296,0	180,0	25,4	72,0	88,0	16,0	120,0	
PEO-80S-MPB	80	2	356,52	353,72	319,0	180,0	25,4	72,0	88,0	16,0	120,0	
PEO-90S-MPB	90	2	401,08	398,29	358,0	200,0	25,4	72,0	88,0	16,0	133,0	GG
PEO-112S-MPB	112	3	499,12	496,33	456,0	200,0	25,4	72,0	88,0	16,0	133,0	
PEO-140S-MPB	140	3	623,91	621,11	581,0	220,0	25,4	72,0	88,0	16,0	147,0	
PEO-168S-MPB	168	3	748,69	745,89	706,0	220,0	25,4	72,0	88,0	16,0	147,0	

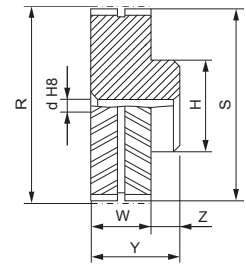

1

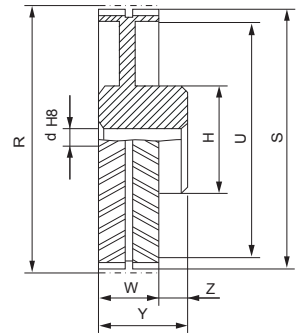

2

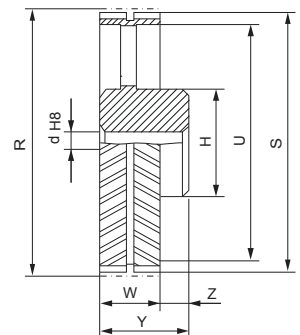

3

Type "Red" R - Largeur de la courroie W = 105 mm

14M

Code	Nb de dents	Type	R [mm]	S [mm]	U [mm]	H [mm]	d [mm]	W [mm]	Y [mm]	Z [mm]	Alésage max [mm]	Matière
PER-28S-MPB	28	1	124,78	121,99	-	109,0	25,4	107,0	133,0	26,0	73,0	acier
PER-30S-MPB	30	1	133,69	130,90	-	117,5	25,4	107,0	133,0	26,0	78,0	
PER-32S-MPB	32	1	142,61	139,81	-	126,5	25,4	107,0	133,0	26,0	84,0	
PER-34S-MPB	34	1	151,52	148,73	-	135,5	25,4	107,0	133,0	26,0	90,0	
PER-36S-MPB	36	1	160,43	157,64	-	144,0	25,4	107,0	133,0	26,0	96,0	
PER-38S-MPB	38	1	169,35	166,55	-	153,0	25,4	107,0	133,0	26,0	102,0	
PER-40S-MPB	40	1	178,26	175,46	-	162,0	25,4	107,0	133,0	26,0	108,0	
PER-43S-MPB	43	1	191,63	188,83	-	174,0	25,4	107,0	133,0	26,0	117,0	
PER-45S-MPB	45	1	200,54	197,75	-	183,0	25,4	107,0	123,0	16,0	122,0	
PER-48S-MPB	48	1	213,91	211,12	-	197,0	25,4	107,0	123,0	16,0	131,0	
PER-50S-MPB	50	1	222,82	220,03	-	205,0	25,4	107,0	123,0	16,0	137,0	
PER-56S-MPB	56	1	249,56	246,77	-	230,0	25,4	107,0	123,0	16,0	153,0	
PER-60S-MPB	60	2	267,39	264,59	230,0	180,0	25,4	107,0	123,0	16,0	120,0	GS400
PER-63S-MPB	63	2	280,76	277,96	243,0	180,0	25,4	107,0	123,0	16,0	120,0	
PER-71S-MPB	71	2	316,41	313,62	279,0	200,0	25,4	107,0	123,0	16,0	133,0	
PER-75S-MPB	75	2	334,24	331,44	296,0	200,0	25,4	107,0	123,0	16,0	133,0	
PER-80S-MPB	80	2	356,52	353,72	319,0	200,0	25,4	107,0	123,0	16,0	133,0	
PER-90S-MPB	90	2	401,08	398,29	358,0	220,0	25,4	107,0	123,0	16,0	147,0	GG
PER-112S-MPB	112	3	499,12	496,33	456,0	220,0	25,4	107,0	123,0	16,0	147,0	
PER-140S-MPB	140	3	623,91	621,11	581,0	240,0	25,4	107,0	123,0	16,0	160,0	
PER-168S-MPB	168	3	748,69	745,89	706,0	240,0	25,4	107,0	123,0	16,0	160,0	

GS400 = fonte GS - GG = fonte grise

Dimensions des poulies dentées EAGLE - moyeu amovible

SER-SIT®

Type 14M



Désignation	PBE	B	32S	2517
Poulies EAGLE- Moyeu amovible				
Largeur de la courroie				
Nombre de dents				
Référence du moyeu amovible				

Type "Blue" B - Largeur de la courroie W = 35 mm

14M

Code	Nb de dents	Type	Moyeu amovible SER-SIT®	R [mm]	S [mm]	U [mm]	H [mm]	W [mm]	Y [mm]	Z [mm]	Matière
PBEB-28S-2012	28	4	2012	124,78	121,99	82,0	-	37,0	32,0	5,0	acier
PBEB-30S-2517	30	1	2517	133,69	130,90	-	114,0	37,0	45,0	8,0	
PBEB-32S-2517	32	1	2517	142,61	139,81	-	123,0	37,0	45,0	8,0	
PBEB-34S-2517	34	1	2517	151,52	148,73	-	132,0	37,0	45,0	8,0	
PBEB-36S-3020	36	1	3020	160,43	157,64	-	141,0	37,0	51,0	14,0	
PBEB-38S-3020	38	1	3020	169,35	166,55	-	150,0	37,0	51,0	14,0	
PBEB-40S-3020	40	1	3020	178,26	175,46	-	159,0	37,0	51,0	14,0	
PBEB-43S-3020	43	1	3020	191,63	188,83	-	172,0	37,0	51,0	14,0	
PBEB-45S-3020	45	1	3020	200,54	197,75	-	181,0	37,0	51,0	14,0	
PBEB-48S-3020	48	1	3020	213,91	211,12	-	195,0	37,0	51,0	14,0	
PBEB-50S-3020	50	2	3020	222,82	220,03	180,0	150,0	37,0	51,0	14,0	GS400
PBEB-56S-3020	56	2	3020	249,56	246,77	207,0	150,0	37,0	51,0	14,0	
PBEB-60S-3020	60	2	3020	267,39	264,59	225,0	150,0	37,0	51,0	14,0	
PBEB-63S-3020	63	2	3020	280,76	277,96	238,0	150,0	37,0	51,0	14,0	
PBEB-71S-3020	71	2	3020	316,41	313,62	274,0	150,0	37,0	51,0	14,0	
PBEB-75S-3020	75	2	3020	334,24	331,44	291,0	150,0	37,0	51,0	14,0	
PBEB-80S-3020	80	2	3020	356,52	353,72	314,0	150,0	37,0	51,0	14,0	GG
PBEB-90S-3020	90	2	3020	401,08	398,29	358,0	150,0	37,0	51,0	14,0	
PBEB-112S-3020	112	3	3020	499,12	496,33	456,0	150,0	37,0	51,0	14,0	
PBEB-140S-3020	140	3	3020	623,91	621,11	581,0	150,0	37,0	51,0	14,0	
PBEB-168S-3020	168	3	3020	748,69	745,89	706,0	150,0	37,0	51,0	14,0	

GS400 = fonte GS - GG = fonte grise

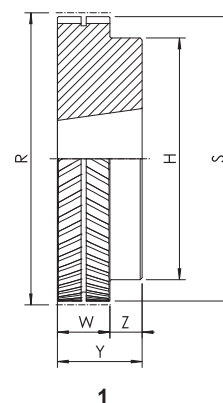

1

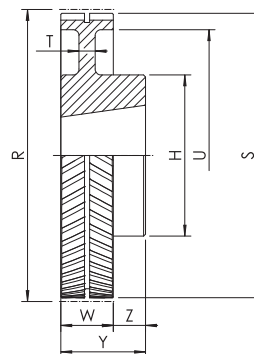

2

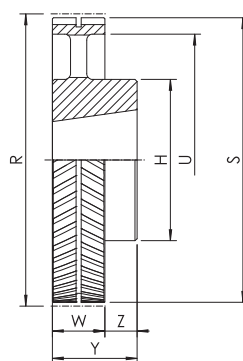

3

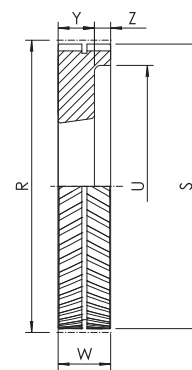

4

Dimensions des poulies dentées EAGLE - moyeu amovible SER-SIT®



Type "Green" G - Largeur de la courroie W = 52,5 mm

14M

Code	Nb de dents	Type	Moyeu amovible-SER-SIT®	R [mm]	S [mm]	U [mm]	H [mm]	W [mm]	Y [mm]	Z [mm]	Matière
PBEG-28S-2517	28	4	2517	124,78	121,99	86,0	-	54,5	45,0	9,5	acier
PBEG-30S-2517	30	4	2517	133,69	130,90	90,0	-	54,5	45,0	9,5	
PBEG-32S-2517	32	4	2517	142,61	139,81	100,0	-	54,5	45,0	9,5	
PBEG-34S-2517	34	4	2517	151,52	148,73	108,0	-	54,5	45,0	9,5	
PBEG-36S-3020	36	4	3020	160,43	157,64	118,0	-	54,5	51,0	3,5	
PBEG-38S-3020	38	4	3020	169,35	166,55	126,0	-	54,5	51,0	3,5	
PBEG-40S-3020	40	4	3020	178,26	175,46	135,0	-	54,5	51,0	3,5	
PBEG-43S-3020	43	4	3020	191,63	188,83	148,0	-	54,5	51,0	3,5	
PBEG-45S-3020	45	4	3020	200,54	197,75	158,0	-	54,5	51,0	3,5	
PBEG-48S-3020	48	4	3020	213,91	211,12	171,0	-	54,5	51,0	3,5	
PBEG-50S-3020	50	8	3020	222,82	220,03	180,0	150,0	54,5	51,0	3,5	GS400
PBEG-56S-3020	56	8	3020	249,56	246,77	207,0	150,0	54,5	51,0	3,5	
PBEG-60S-3020	60	8	3020	267,39	264,59	225,0	150,0	54,5	51,0	3,5	
PBEG-63S-3020	63	8	3020	280,76	277,96	238,0	150,0	54,5	51,0	3,5	
PBEG-71S-3020	71	8	3020	316,41	313,62	274,0	150,0	54,5	51,0	3,5	
PBEG-75S-3020	75	8	3020	334,24	331,44	291,0	150,0	54,5	51,0	3,5	
PBEG-80S-3020	80	8	3020	356,52	353,72	314,0	150,0	54,5	51,0	3,5	
PBEG-90S-3020	90	8	3020	401,08	398,29	358,0	180,0	54,5	51,0	3,5	
PBEG-112S-3020	112	10	3020	499,12	496,33	456,0	180,0	54,5	51,0	3,5	GG
PBEG-140S-3020	140	10	3020	623,91	621,11	581,0	200,0	54,5	51,0	3,5	
PBEG-168S-3020	168	10	3020	748,69	745,89	706,0	200,0	54,5	51,0	3,5	

GS400 = fonte GS - GG = fonte grise

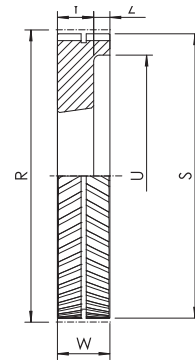

4

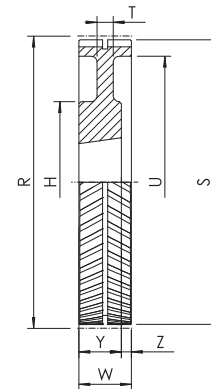

8

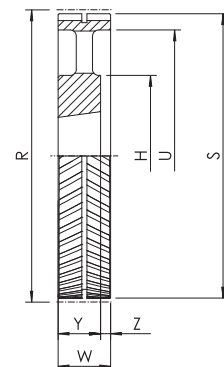

10

Dimensions des poulies dentées EAGLE - moyeu amovible SER-SIT®



Type "Orange" O - Largeur de la courroie W = 70 mm

14M

Code	Nb de dents	Type	Moyeu amovible-SER-SIT®	R [mm]	S [mm]	U [mm]	H [mm]	W [mm]	Y [mm]	Z [mm]	Matière
PBEO-28S-2517	28	4	2517	124,78	121,99	86,0	-	72,0	45,0	27,0	acier
PBEO-30S-2517	30	4	2517	133,69	130,90	90,0	-	72,0	45,0	27,0	
PBEO-32S-2517	32	4	2517	142,61	139,81	100,0	-	72,0	45,0	27,0	
PBEO-34S-3030	34	1	3030	151,52	148,73	-	135,5	72,0	76,0	4,0	
PBEO-36S-3030	36	1	3030	160,43	157,64	-	144,0	72,0	76,0	4,0	
PBEO-38S-3030	38	1	3030	169,35	166,55	-	153,0	72,0	76,0	4,0	
PBEO-40S-3030	40	1	3030	178,26	175,46	-	162,0	72,0	76,0	4,0	
PBEO-43S-3535	43	1	3535	191,63	188,83	-	174,0	72,0	89,0	17,0	
PBEO-45S-3535	45	1	3535	200,54	197,75	-	183,0	72,0	89,0	17,0	
PBEO-48S-3535	48	1	3535	213,91	211,12	-	197,0	72,0	89,0	17,0	
PBEO-50S-3535	50	1	3535	222,82	220,03	-	205,0	72,0	89,0	17,0	
PBEO-56S-3535	56	1	3535	249,56	246,77	-	230,0	72,0	89,0	17,0	
PBEO-60S-3030	60	2	3030	267,39	264,59	225,0	150,0	72,0	76,0	4,0	GS400
PBEO-63S-3030	63	2	3030	280,76	277,96	238,0	150,0	72,0	76,0	4,0	
PBEO-71S-3030	71	2	3030	316,41	313,62	274,0	150,0	72,0	76,0	4,0	
PBEO-75S-3535	75	2	3535	334,24	331,44	291,0	180,0	72,0	89,0	17,0	
PBEO-80S-3535	80	2	3535	356,52	353,72	314,0	180,0	72,0	89,0	17,0	
PBEO-90S-3535	90	2	3535	401,08	398,29	358,0	200,0	72,0	89,0	17,0	GG
PBEO-112S-3535	112	3	3535	499,12	496,33	456,0	200,0	72,0	89,0	17,0	
PBEO-140S-3535	140	3	3535	623,91	621,11	581,0	220,0	72,0	89,0	17,0	
PBEO-168S-3535	168	3	3535	748,69	745,89	706,0	220,0	72,0	89,0	17,0	

GS400 = fonte GS - GG = fonte grise

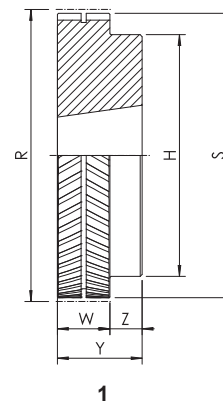

1

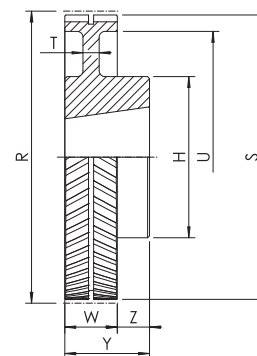

2

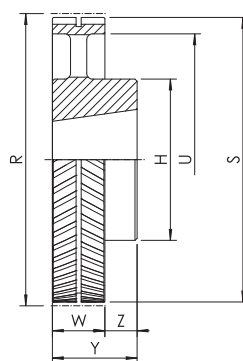

7

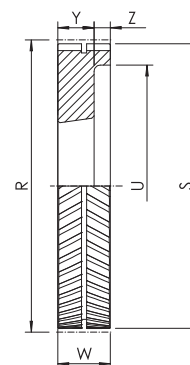

4

Dimensions des poulies dentées EAGLE - moyeu amovible SER-SIT®

Type "Red" R - Largeur de la courroie W = 105 mm

14M



Code	Nb de dents	Type	Moyeu amovible-SER-SIT®	R [mm]	S [mm]	U [mm]	H [mm]	W [mm]	Y [mm]	Z [mm]	Matière
PBER -28S-2517	28	9	2517	124,78	121,99	86,0	-	107,0	45,0	31,0	acier
PBER -30S-2517	30	9	2517	133,69	130,90	90,0	-	107,0	45,0	31,0	
PBER -32S-2517	32	9	2517	142,61	139,81	100,0	-	107,0	45,0	31,0	
PBER -34S-3030	34	9	3030	151,52	148,73	109,0	-	107,0	76,0	15,5	
PBER -36S-3030	36	9	3030	160,43	157,64	117,0	-	107,0	76,0	15,5	
PBER -38S-3030	38	9	3030	169,35	166,55	126,0	-	107,0	76,0	15,5	
PBER -40S-3030	40	9	3030	178,26	175,46	135,0	-	107,0	76,0	15,5	
PBER -43S-3535	43	4	3535	191,63	188,83	148,0	-	107,0	89,0	18,0	
PBER -45S-3535	45	4	3535	200,54	197,75	157,0	-	107,0	89,0	18,0	
PBER -48S-4040	48	4	4040	213,91	211,12	171,0	-	107,0	102,0	5,0	
PBER -50S-4040	50	4	4040	222,82	220,03	180,0	-	107,0	102,0	5,0	
PBER -56S-4040	56	4	4040	249,56	246,77	206,0	-	107,0	102,0	5,0	
PBER -60S-3535	60	8	3535	267,39	264,59	225,0	180,0	107,0	89,0	18,0	
PBER -63S-3535	63	8	3535	280,76	277,96	238,0	180,0	107,0	89,0	18,0	
PBER -71S-4040	71	8	4040	316,41	313,62	274,0	200,0	107,0	102,0	5,0	
PBER -75S-4040	75	8	4040	334,24	331,44	291,0	200,0	107,0	102,0	5,0	
PBER -80S-4040	80	8	4040	356,52	353,72	314,0	200,0	107,0	102,0	5,0	
PBER -90S-4040	90	8	4040	401,08	398,29	358,0	220,0	107,0	102,0	5,0	
PBER -112S-4040	112	10	4040	499,12	496,33	456,0	220,0	107,0	102,0	5,0	
PBER -140S-5050	140	3	5050	623,91	621,11	581,0	240,0	107,0	127,0	20,0	
PBER -168S-5050	168	3	5050	748,69	745,89	706,0	240,0	107,0	127,0	20,0	

GS400 = fonte GS - GG = fonte grise

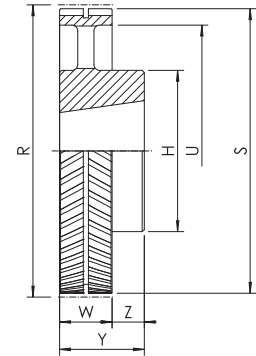

3

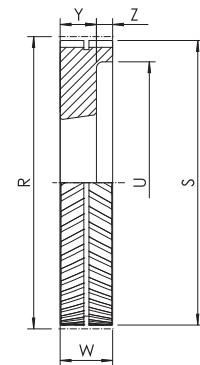

4

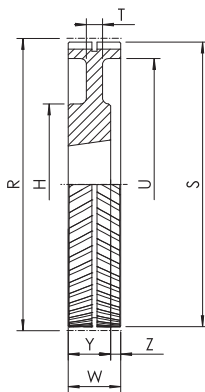

8

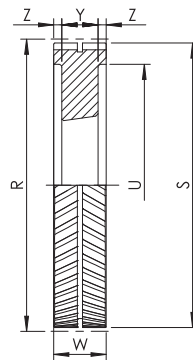

9

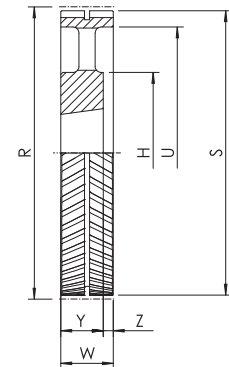

10

Dimensions des poulies dentées EAGLE - moyeu plein aluminium



Désignation	PE5M 12.5	15S	MPB
Poulies EAGLE- moyeu plein			
Largeur de la courroie			
Nombre de dents			
Moyeu plein			

PE5M - Largeur de la courroie 12,5 mm

5M

Code	Nb de dents	Type	R [mm]	S [mm]	U [mm]	H [mm]	d [mm]	W [mm]	Y [mm]	Z [mm]	Matière
PE5M12,5-15S-MPB	15	1	23,87	22,91	-	17,0	6,0	13,5	19,5	6,0	aluminium
PE5M12,5-16S-MPB	16	1	25,47	24,51	-	19,0	6,0	13,5	19,5	6,0	
PE5M12,5-18S-MPB	18	1	28,65	27,69	-	22,0	6,0	13,5	19,5	6,0	
PE5M12,5-19S-MPB	19	1	30,23	29,27	-	24,0	6,0	13,5	21,5	8,0	
PE5M12,5-20S-MPB	20	1	31,83	30,87	-	25,0	6,0	13,5	21,5	8,0	
PE5M12,5-22S-MPB	22	1	35,01	34,05	-	28,0	6,0	13,5	21,5	8,0	
PE5M12,5-24S-MPB	24	1	38,19	37,23	-	32,0	6,0	13,5	21,5	8,0	
PE5M12,5-25S-MPB	25	1	39,79	38,83	-	33,0	6,0	13,5	21,5	8,0	
PE5M12,5-26S-MPB	26	1	41,38	40,42	-	35,0	6,0	13,5	21,5	8,0	
PE5M12,5-27S-MPB	27	1	42,97	42,01	-	36,0	6,0	13,5	21,5	8,0	
PE5M12,5-28S-MPB	28	1	44,56	43,60	-	38,0	6,0	13,5	21,5	8,0	
PE5M12,5-30S-MPB	30	1	47,75	46,79	-	41,0	12,7	13,5	21,5	8,0	
PE5M12,5-32S-MPB	32	1	50,93	49,97	-	44,0	12,7	13,5	21,5	8,0	
PE5M12,5-36S-MPB	36	1	57,30	56,34	-	51,0	12,7	13,5	21,5	8,0	
PE5M12,5-40S-MPB	40	1	63,66	62,70	-	57,0	12,7	13,5	24,5	11,0	
PE5M12,5-44S-MPB	44	1	70,03	69,07	-	63,0	12,7	13,5	24,5	11,0	
PE5M12,5-48S-MPB	48	1	76,39	75,43	-	70,0	12,7	13,5	24,5	11,0	
PE5M12,5-60S-MPB	60	1	95,49	94,53	-	89,0	12,7	13,5	24,5	11,0	

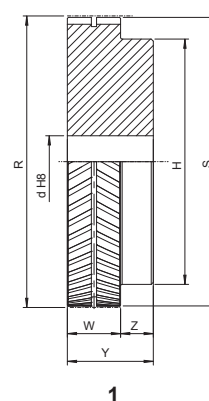

PE5M - Largeur de la courroie 25 mm

5M

Code	Nb de dents	Type	R [mm]	S [mm]	U [mm]	H [mm]	d [mm]	W [mm]	Y [mm]	Z [mm]	Matière
PE5M25-15S-MPB	15	1	23,87	22,91	-	17,0	6,0	26,0	32,0	6,0	aluminium
PE5M25-16S-MPB	16	1	25,47	24,51	-	19,0	6,0	26,0	32,0	6,0	
PE5M25-18S-MPB	18	1	28,65	27,69	-	22,0	6,0	26,0	32,0	6,0	
PE5M25-19S-MPB	19	1	30,23	29,27	-	24,0	6,0	26,0	34,0	8,0	
PE5M25-20S-MPB	20	1	31,83	30,87	-	25,0	6,0	26,0	34,0	8,0	
PE5M25-22S-MPB	22	1	35,01	34,05	-	28,0	6,0	26,0	34,0	8,0	
PE5M25-24S-MPB	24	1	38,19	37,23	-	32,0	6,0	26,0	34,0	8,0	
PE5M25-25S-MPB	25	1	39,79	38,83	-	33,0	6,0	26,0	34,0	8,0	
PE5M25-26S-MPB	26	1	41,38	40,42	-	35,0	6,0	26,0	34,0	8,0	
PE5M25-27S-MPB	27	1	42,97	42,01	-	36,0	6,0	26,0	34,0	8,0	
PE5M25-28S-MPB	28	1	44,56	43,60	-	38,0	6,0	26,0	34,0	8,0	
PE5M25-30S-MPB	30	1	47,75	46,79	-	41,0	12,7	26,0	34,0	8,0	
PE5M25-32S-MPB	32	1	50,93	49,97	-	44,0	12,7	26,0	34,0	8,0	
PE5M25-36S-MPB	36	1	57,30	56,34	-	51,0	12,7	26,0	34,0	8,0	
PE5M25-40S-MPB	40	1	63,66	62,70	-	57,0	12,7	26,0	37,0	11,0	
PE5M25-44S-MPB	44	1	70,03	69,07	-	63,0	12,7	26,0	37,0	11,0	
PE5M25-48S-MPB	48	1	76,39	75,43	-	70,0	12,7	26,0	37,0	11,0	
PE5M25-60S-MPB	60	1	95,49	94,53	-	89,0	12,7	26,0	37,0	11,0	

Dimensions des poulies dentées EAGLE - moyeu plein aluminum



Désignation	PE	M	20S	MPB
Poulies EAGLE- moyeu plein				
Largeur de la courroie				
Nombre de dents				
Moyeu plein				

PEM - Largeur de la courroie 25 mm

8M

Code	Nb de dents	Type	R [mm]	S [mm]	H [mm]	d [mm]	W [mm]	Y [mm]	Z [mm]	Alésage max	Matière
PEM-20S-MPB	20	1	50,93	49,55	41,0	12,7	26,0	38,0	12,0	27,0	aluminum
PEM-22S-MPB	22	1	56,02	54,64	46,0	12,7	26,0	38,0	12,0	31,0	
PEM-24S-MPB	24	1	61,12	59,74	51,0	12,7	26,0	42,0	16,0	34,0	
PEM-26S-MPB	26	1	66,21	64,83	58,0	12,7	26,0	42,0	16,0	39,0	
PEM-28S-MPB	28	1	71,30	69,92	62,0	12,7	26,0	42,0	16,0	41,0	
PEM-30S-MPB	30	1	76,39	75,01	67,0	12,7	26,0	42,0	16,0	45,0	
PEM-32S-MPB	32	1	81,49	80,11	72,0	12,7	26,0	42,0	16,0	48,0	
PEM-34S-MPB	34	1	86,58	85,20	77,0	12,7	26,0	42,0	16,0	51,0	
PEM-36S-MPB	36	1	91,67	90,29	82,0	12,7	26,0	42,0	16,0	55,0	
PEM-38S-MPB	38	1	96,77	95,39	87,0	12,7	26,0	42,0	16,0	58,0	
PEM-40S-MPB	40	1	101,86	100,48	92,0	12,7	26,0	42,0	16,0	62,0	
PEM-56S-MPB	56	1	142,60	141,22	133,0	12,7	26,0	42,0	16,0	89,0	
PEM-90S-MPB	90	2	229,18	227,80	120,0	25,4	26,0	42,0	16,0	80,0	

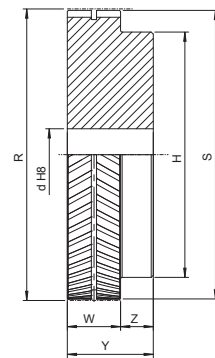

1

PEL - Largeur de la courroie 50 mm

8M

Code	Nb de dents	Type	R [mm]	S [mm]	H [mm]	d [mm]	W [mm]	Y [mm]	Z [mm]	Alésage max	Matière
PEL-20S-MPB	20	1	50,93	49,55	41,0	12,7	51,0	63,0	12,0	27,0	aluminum
PEL-22S-MPB	22	1	56,02	54,64	46,0	12,7	51,0	63,0	12,0	31,0	
PEL-24S-MPB	24	1	61,12	59,74	51,0	12,7	51,0	67,0	16,0	34,0	
PEL-26S-MPB	26	1	66,21	64,83	58,0	12,7	51,0	67,0	16,0	39,0	
PEL-28S-MPB	28	1	71,30	69,92	62,0	12,7	51,0	67,0	16,0	41,0	
PEL-30S-MPB	30	1	76,39	75,01	67,0	12,7	51,0	67,0	16,0	45,0	
PEL-32S-MPB	32	1	81,49	80,11	72,0	12,7	51,0	67,0	16,0	48,0	
PEL-34S-MPB	34	1	86,58	85,20	77,0	12,7	51,0	67,0	16,0	51,0	
PEL-36S-MPB	36	1	91,67	90,29	82,0	12,7	51,0	67,0	16,0	55,0	
PEL-38S-MPB	38	1	96,77	95,39	87,0	12,7	51,0	67,0	16,0	58,0	
PEL-40S-MPB	40	1	101,86	100,48	92,0	12,7	51,0	67,0	16,0	62,0	
PEL-56S-MPB	56	1	142,60	141,22	133,0	12,7	51,0	67,0	16,0	89,0	
PEL-90S-MPB	90	2	229,18	227,80	120,0	25,4	51,0	67,0	16,0	80,0	

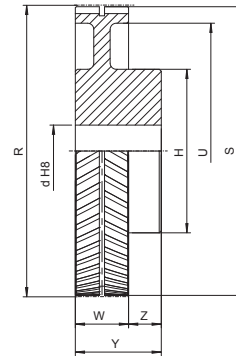

2

Dimensions des poulies dentées EAGLE - moyeu plein aluminium



Désignation	PE10M 25	15S	MPB
Poulies EAGLE- moyeu plein			
Largeur de la courroie			
Nombre de dents			
Moyeu plein			

PE10M - Largeur de la courroie 25 mm

10M

Code	Nb de dents	Type	R [mm]	S [mm]	U [mm]	H [mm]	d [mm]	W [mm]	Y [mm]	Z [mm]	Alésage max [mm]	Matière
PE10M25-15S-MPB	15	1	47,75	45,75	-	35,0	12,70	26,0	36,0	10,0	23,0	aluminium
PE10M25-16S-MPB	16	1	50,93	48,93	-	38,0	12,70	26,0	36,0	10,0	25,0	
PE10M25-18S-MPB	18	1	57,30	55,30	-	44,0	12,70	26,0	36,0	10,0	30,0	
PE10M25-19S-MPB	19	1	60,48	58,48	-	47,0	12,70	26,0	36,0	10,0	32,0	
PE10M25-20S-MPB	20	1	63,66	61,66	-	51,0	12,70	26,0	36,0	10,0	34,0	
PE10M25-22S-MPB	22	1	70,03	68,03	-	57,0	12,70	26,0	36,0	10,0	38,0	
PE10M25-24S-MPB	24	1	76,39	74,39	-	63,0	12,70	26,0	36,0	10,0	42,0	
PE10M25-25S-MPB	25	1	79,58	77,58	-	67,0	12,70	26,0	36,0	10,0	44,0	
PE10M25-26S-MPB	26	1	82,76	80,76	-	70,0	12,70	26,0	36,0	10,0	47,0	
PE10M25-27S-MPB	27	1	85,94	83,94	-	73,0	12,70	26,0	36,0	10,0	49,0	
PE10M25-28S-MPB	28	1	89,13	87,13	-	76,0	12,70	26,0	36,0	10,0	51,0	
PE10M25-30S-MPB	30	1	95,49	93,49	-	82,0	12,70	26,0	36,0	10,0	55,0	
PE10M25-32S-MPB	32	1	101,86	99,86	-	89,0	12,70	26,0	36,0	10,0	59,0	
PE10M25-36S-MPB	36	1	114,59	112,59	-	102,0	12,70	26,0	36,0	10,0	68,0	
PE10M25-40S-MPB	40	1	127,32	125,32	-	114,0	12,70	26,0	36,0	10,0	76,0	
PE10M25-44S-MPB	44	1	140,06	138,06	-	127,0	12,70	26,0	36,0	10,0	85,0	
PE10M25-48S-MPB	48	1	152,79	150,79	-	140,0	12,70	26,0	36,0	10,0	93,0	
PE10M25-60S-MPB	60	2	190,99	188,99	162,0	110,0	25,40	26,0	36,0	10,0	65,0	

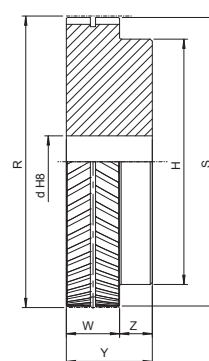

1

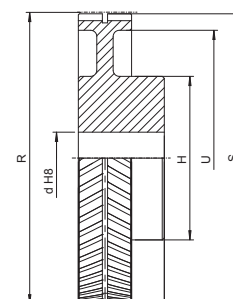

2

PE10M - Largeur de la courroie 32 mm

10M

Code	Nb de dents	Type	R [mm]	S [mm]	U [mm]	H [mm]	d [mm]	W [mm]	Y [mm]	Z [mm]	Alésage max [mm]	Matière
PE10M32-15S-MPB	15	1	47,75	45,75	-	35,0	12,70	33,0	43,0	10,0	23,0	aluminium
PE10M32-16S-MPB	16	1	50,93	48,93	-	38,0	12,70	33,0	43,0	10,0	25,0	
PE10M32-18S-MPB	18	1	57,30	55,30	-	44,0	12,70	33,0	43,0	10,0	30,0	
PE10M32-19S-MPB	19	1	60,48	58,48	-	47,0	12,70	33,0	43,0	10,0	32,0	
PE10M32-20S-MPB	20	1	63,66	61,66	-	51,0	12,70	33,0	43,0	10,0	34,0	
PE10M32-22S-MPB	22	1	70,03	68,03	-	57,0	12,70	33,0	43,0	10,0	38,0	
PE10M32-24S-MPB	24	1	76,39	74,39	-	63,0	12,70	33,0	43,0	10,0	42,0	
PE10M32-25S-MPB	25	1	79,58	77,58	-	67,0	12,70	33,0	43,0	10,0	44,0	
PE10M32-26S-MPB	26	1	82,76	80,76	-	70,0	12,70	33,0	43,0	10,0	47,0	
PE10M32-27S-MPB	27	1	85,94	83,94	-	73,0	12,70	33,0	43,0	10,0	49,0	
PE10M32-28S-MPB	28	1	89,13	87,13	-	76,0	12,70	33,0	43,0	10,0	51,0	
PE10M32-30S-MPB	30	1	95,49	93,49	-	82,0	12,70	33,0	43,0	10,0	55,0	
PE10M32-32S-MPB	32	1	101,86	99,86	-	89,0	12,70	33,0	43,0	10,0	59,0	
PE10M32-36S-MPB	36	1	114,59	112,59	-	102,0	12,70	33,0	43,0	10,0	68,0	
PE10M32-40S-MPB	40	1	127,32	125,32	-	114,0	12,70	33,0	43,0	10,0	76,0	
PE10M32-44S-MPB	44	1	140,06	138,06	-	127,0	12,70	33,0	43,0	10,0	85,0	
PE10M32-48S-MPB	48	1	152,79	150,79	-	140,0	12,70	33,0	43,0	10,0	93,0	
PE10M32-60S-MPB	60	2	190,99	188,99	161,0	178,0	25,40	33,0	43,0	10,0	105,0	

Dimensions des poulies dentées EAGLE - moyeu plein aluminium



PE10M - Largeur de la courroie 50 mm

10M

Code	Nb de dents	Type	R [mm]	S [mm]	U [mm]	H [mm]	d [mm]	W [mm]	Y [mm]	Z [mm]	Alésage max [mm]	Matière
PE10M50-15S-MPB	15	1	47,75	45,75	-	35,0	12,70	51,0	61,0	10,0	23,0	aluminium
PE10M50-16S-MPB	16	1	50,93	48,93	-	38,0	12,70	51,0	61,0	10,0	25,0	
PE10M50-18S-MPB	18	1	57,30	55,30	-	44,0	12,70	51,0	61,0	10,0	30,0	
PE10M50-19S-MPB	19	1	60,48	58,48	-	47,0	12,70	51,0	61,0	10,0	32,0	
PE10M50-20S-MPB	20	1	63,66	61,66	-	51,0	12,70	51,0	61,0	10,0	34,0	
PE10M50-22S-MPB	22	1	70,03	68,03	-	57,0	12,70	51,0	61,0	10,0	38,0	
PE10M50-24S-MPB	24	1	76,39	74,39	-	63,0	12,70	51,0	61,0	10,0	42,0	
PE10M50-25S-MPB	25	1	79,58	77,58	-	67,0	12,70	51,0	61,0	10,0	44,0	
PE10M50-26S-MPB	26	1	82,76	80,76	-	70,0	12,70	51,0	61,0	10,0	47,0	
PE10M50-27S-MPB	27	1	85,94	83,94	-	73,0	12,70	51,0	61,0	10,0	49,0	
PE10M50-28S-MPB	28	1	89,13	87,13	-	76,0	12,70	51,0	61,0	10,0	51,0	
PE10M50-30S-MPB	30	1	95,49	93,49	-	82,0	12,70	51,0	61,0	10,0	55,0	
PE10M50-32S-MPB	32	1	101,86	99,86	-	89,0	12,70	51,0	61,0	10,0	59,0	
PE10M50-36S-MPB	36	1	114,59	112,59	-	102,0	12,70	51,0	61,0	10,0	68,0	
PE10M50-40S-MPB	40	1	127,32	125,32	-	114,0	12,70	51,0	61,0	10,0	76,0	
PE10M50-44S-MPB	44	1	140,06	138,06	-	127,0	12,70	51,0	61,0	10,0	85,0	
PE10M50-48S-MPB	48	1	152,79	150,79	-	140,0	12,70	51,0	61,0	10,0	93,0	
PE10M50-60S-MPB	60	2	190,99	188,99	161,0	178,0	25,40	51,0	61,0	10,0	105,0	

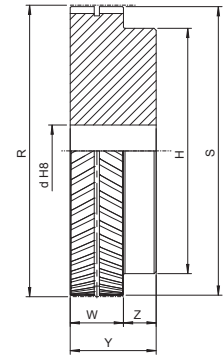

1

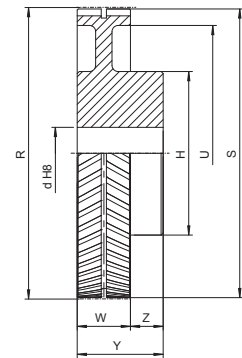

2

Barreaux dentés



Types MXL - XL - L

Les barreaux dentés "MXL" sont en aluminium 6082 adapté aux traitements d'anodisation dure.
Les barreaux "XL" et "L" sont en acier C45 et en aluminium 6082, adaptés aux traitements d'anodisation dure.

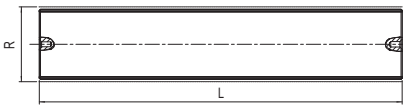

1

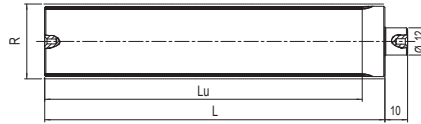

3

Dimensions

MXL 0,080" (2,032 mm)					
ALUMINIUM					
Code	Nb de dents.	Type	R [mm]	Lu [mm]	L [mm]
BAR10MXL*	10	3	6,47	50	75
BAR11MXL*	11	3	7,11	50	75
BAR12MXL	12	3	7,76	50	75
BAR13MXL*	13	3	8,41	50	75
BAR14MXL	14	3	9,06	50	75
BAR15MXL	15	3	9,70	50	75
BAR16MXL	16	3	10,35	50	75
BAR17MXL*	17	3	11,00	50	75
BAR18MXL	18	3	11,64	50	75
BAR19MXL*	19	3	12,29	90	120
BAR20MXL	20	3	12,94	90	120
BAR21MXL*	21	3	13,58	90	120
BAR22MXL	22	3	14,23	125	140
BAR23MXL*	23	3	14,88	125	140
BAR24MXL	24	3	15,52	125	140
BAR25MXL	25	3	16,17	125	140
BAR26MXL	26	3	16,82	125	140
BAR27MXL*	27	3	17,46	125	140
BAR28MXL	28	3	18,11	125	140
BAR29MXL*	29	3	18,76	125	140
BAR30MXL	30	3	19,40	125	140
BAR32MXL	32	3	20,70	125	140
BAR34MXL	34	3	21,99	125	140
BAR35MXL*	35	3	22,64	132	140
BAR36MXL	36	3	23,29	132	140
BAR38MXL	38	3	24,58	132	140
BAR40MXL	40	3	25,87	132	140
BAR42MXL	42	3	27,17	140	140
BAR44MXL	44	3	28,46	140	140
BAR45MXL	45	3	29,11	140	140
BAR48MXL	48	3	31,05	140	140
BAR50MXL*	50	3	32,34	140	140
BAR60MXL	60	3	38,81	160	160
BAR64MXL*	64	3	41,40	160	160
BAR65MXL*	65	3	42,04	160	160
BAR70MXL	70	3	45,28	160	160
BAR72MXL	72	3	46,57	160	160
BAR75MXL*	75	3	48,51	160	160
BAR90MXL*	90	3	58,21	160	160
BAR110MXL*	110	3	71,15	160	160

XL 1/5" (5,08 mm)					
ACIER - ALUMINIUM					
Code	Nb de dents.	Type	R [mm]	Lu [mm]	L [mm]
BAR10XL	10	1	16,17	140	140
BAR11XL	11	1	17,79	140	140
BAR12XL	12	1	19,4	140	140
BAR13XL	13	1	21,02	140	140
BAR14XL	14	1	22,64	140	140
BAR15XL	15	1	24,25	140	140
BAR16XL	16	1	25,87	140	140
BAR17XL	17	1	27,49	140	140
BAR18XL	18	1	29,11	140	140
BAR19XL	19	1	30,72	140	140
BAR20XL	20	1	32,34	140	140
BAR21XL	21	1	33,96	160	160
BAR22XL	22	1	35,57	160	160
BAR23XL	23	1	37,19	160	160
BAR24XL	24	1	38,81	160	160
BAR25XL	25	1	40,43	160	160
BAR26XL	26	1	42,04	160	160
BAR27XL	27	1	43,66	160	160
BAR28XL	28	1	45,28	160	160
BAR29XL	29	1	46,89	160	160
BAR30XL	30	1	48,51	160	160
BAR32XL	32	1	51,74	160	160
BAR33XL	33	1	53,36	160	160
BAR34XL	34	1	54,98	160	160
BAR35XL	35	1	56,6	160	160
BAR36XL	36	1	58,21	160	160
BAR38XL	38	1	61,45	160	160
BAR39XL	39	1	63,06	160	160
BAR40XL	40	1	64,68	160	160
BAR41XL	41	1	66,3	160	160
BAR42XL	42	1	67,91	160	160
BAR43XL	43	1	69,53	160	160
BAR44XL	44	1	71,15	160	160
BAR48XL	48	1	77,62	160	160
BAR56XL	56	1	90,55	160	160
BAR60XL	60	1	97,02	160	160
BAR72XL	72	1	116,43	160	160

L 3/8" (9,525 mm)					
ACIER - ALUMINIUM					
Code	Nb de dents.	Type	R [mm]	Lu [mm]	L [mm]
BAR10L	10	1	30,32	140	140
BAR11L	11	1	33,35	140	140
BAR12L	12	1	36,38	160	160
BAR13L	13	1	39,41	160	160
BAR14L	14	1	42,45	160	160
BAR15L	15	1	45,48	160	160
BAR16L	16	1	48,51	160	160
BAR17L	17	1	51,54	160	160
BAR18L	18	1	54,57	160	160
BAR19L	19	1	57,61	160	160
BAR20L	20	1	60,64	160	160
BAR21L	21	1	63,67	160	160
BAR22L	22	1	66,7	160	160
BAR23L	23	1	69,73	160	160
BAR24L	24	1	72,77	160	160
BAR27L	27	1	81,86	160	160
BAR30L	30	1	90,96	160	160

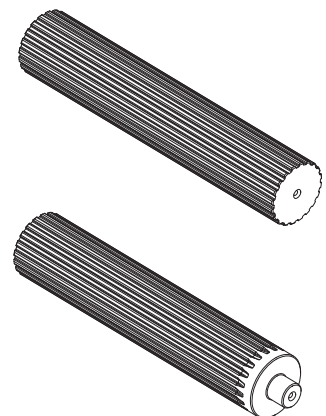

1

3

Désignation	BAR 40 XL / AC
Barreau denté	
Nombre de dents	
Pas	
Matière - AC: acier; AL: aluminium	

*= disponible sur demande

Types 3M - 5M - 8M

Les barreaux dentés “TOP DRIVE® HTD” sont en aluminium 6082 adapté aux traitements d’anodisation dure.

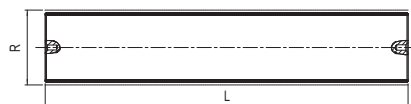

1

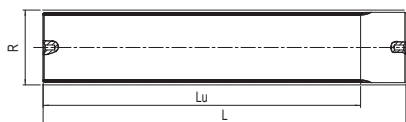

2

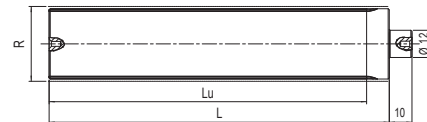

3

Dimensions

HTD 3M pas 3 mm					
ALUMINUM					
Code	Nb de dents.	Type	R [mm]	Lu [mm]	L [mm]
BAR9-3M*	9	3	8,59	75	100
BAR10-3M	10	3	9,55	75	100
BAR11-3M*	11	3	10,50	75	100
BAR12-3M	12	3	11,46	100	125
BAR13-3M*	13	3	12,41	100	125
BAR14-3M	14	3	13,37	100	125
BAR15-3M	15	3	14,32	100	125
BAR16-3M	16	3	15,28	125	155
BAR17-3M*	17	3	16,23	125	155
BAR18-3M	18	3	17,19	125	155
BAR19-3M*	19	3	18,14	125	155
BAR20-3M	20	3	19,10	150	165
BAR21-3M	21	3	20,05	150	165
BAR22-3M	22	3	21,01	150	165
BAR23-3M*	23	3	21,96	150	165
BAR24-3M	24	3	22,92	150	165
BAR25-3M*	25	3	23,87	150	165
BAR26-3M	26	3	24,83	150	165
BAR27-3M*	27	3	25,78	150	165
BAR28-3M	28	3	26,74	150	165
BAR29-3M*	29	3	27,69	150	165
BAR30-3M	30	3	28,65	175	183
BAR31-3M*	31	3	29,60	175	183
BAR32-3M	32	3	30,56	175	183
BAR33-3M*	33	3	31,51	175	183
BAR34-3M	34	3	32,47	175	183
BAR35-3M*	35	3	33,42	175	183
BAR36-3M	36	3	34,38	200	200
BAR37-3M*	37	3	35,33	200	200
BAR38-3M	38	3	36,29	200	200
BAR39-3M*	39	3	37,24	200	200
BAR40-3M	40	3	38,20	200	200
BAR42-3M*	42	3	40,11	200	200
BAR44-3M	44	3	42,02	200	200
BAR45-3M*	45	3	42,97	200	200
BAR48-3M	48	3	45,84	200	200
BAR50-3M*	50	3	47,75	200	200
BAR52-3M*	52	3	49,66	200	200
BAR54-3M*	54	3	51,57	200	200
BAR56-3M*	56	3	53,48	200	200
BAR60-3M	60	3	57,30	200	200
BAR62-3M*	62	3	59,21	200	200
BAR64-3M*	64	3	61,12	200	200
BAR66-3M*	66	3	63,03	200	200
BAR68-3M*	68	3	64,94	200	200
BAR70-3M*	70	3	66,85	200	200
BAR72-3M*	72	3	68,75	200	200

HTD 5M pas 5 mm					
ALUMINUM					
Code	Nb de dents.	Type	R [mm]	Lu [mm]	L [mm]
BAR12-5M	12	2	19,10	150	165
BAR13-5M	13	2	20,69	150	165
BAR14-5M	14	2	22,28	175	183
BAR15-5M	15	2	23,87	175	183
BAR16-5M	16	2	25,46	175	183
BAR17-5M	17	2	27,06	175	183
BAR18-5M	18	1	28,65	200	200
BAR19-5M	19	1	30,24	200	200
BAR20-5M	20	1	31,83	200	200
BAR21-5M	21	1	33,42	200	200
BAR22-5M	22	1	35,01	200	200
BAR23-5M	23	1	36,61	200	200
BAR24-5M	24	1	38,20	200	200
BAR25-5M	25	1	39,79	200	200
BAR26-5M	26	1	41,38	200	200
BAR27-5M	27	1	42,97	200	200
BAR28-5M	28	1	44,56	200	200
BAR29-5M	29	1	46,15	200	200
BAR30-5M	30	1	47,75	200	200
BAR31-5M	31	1	49,34	200	200
BAR32-5M	32	1	50,93	200	200
BAR33-5M	33	1	52,52	200	200
BAR34-5M	34	1	54,11	200	200
BAR35-5M	35	1	55,70	200	200
BAR36-5M	36	1	57,30	200	200
BAR38-5M	38	1	60,48	200	200
BAR40-5M	40	1	63,66	200	200
BAR42-5M	42	1	66,85	200	200
BAR44-5M	44	1	70,03	200	200
BAR45-5M	45	1	71,62	200	200
BAR46-5M	46	1	73,21	200	200
BAR48-5M	48	1	76,39	200	200
BAR50-5M	50	1	79,58	200	200
BAR54-5M	54	1	85,94	200	200
BAR60-5M	60	1	95,49	200	200
BAR62-5M	62	1	98,68	200	200
BAR72-5M	72	1	114,59	200	200

HTD 8M pas 8 mm					
ALUMINUM					
Code	Nb de dents.	Type	R [mm]	Lu [mm]	L [mm]
BAR18-8M	18	1	45,84	200	200
BAR19-8M	19	1	48,38	200	200
BAR20-8M	20	1	50,93	200	200
BAR21-8M	21	1	53,48	200	200
BAR22-8M	22	1	56,02	200	200
BAR23-8M	23	1	58,57	200	200
BAR24-8M	24	1	61,12	200	200
BAR25-8M	25	1	63,66	200	200
BAR26-8M	26	1	66,21	200	200
BAR28-8M	28	1	71,30	200	200
BAR30-8M	30	1	76,39	200	200
BAR32-8M	32	1	81,49	200	200
BAR34-8M	34	1	86,58	200	200
BAR35-8M	35	1	89,13	200	200
BAR36-8M	36	1	91,67	200	200
BAR38-8M	38	1	96,77	200	200
BAR40-8M	40	1	101,86	200	200
BAR44-8M	44	1	112,05	200	200
BAR48-8M	48	1	122,23	200	200

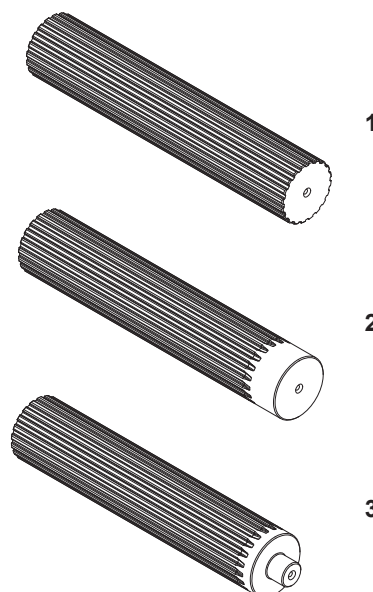

Désignation **BAR 25 - 5M / AL**

Barreau denté

Nombre de dents

Pas

Matière - AL: aluminum

*= disponible sur demande

Types T 2,5 - T 5 - T 10

Les barreaux dentés "T" sont en aluminium 6082 adapté aux traitements d'anodisation dure.

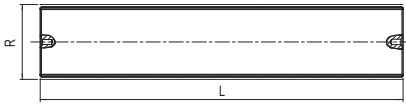

1

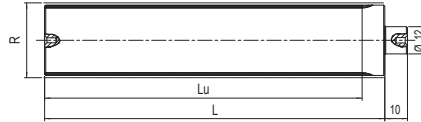

3

Dimensions

T 2,5 (pas 2,5 mm)					
ALUMINUM					
Code	Nb de dents.	Type	R [mm]	Lu [mm]	L [mm]
BAR10T2,5	10	3	7,96	50	75
BAR12T2,5	12	3	9,55	50	75
BAR13T2,5	13	3	10,35	50	75
BAR14T2,5	14	3	11,14	50	75
BAR15T2,5	15	3	11,94	50	75
BAR16T2,5	16	3	12,73	50	75
BAR17T2,5	17	3	13,53	50	75
BAR18T2,5	18	3	14,32	50	75
BAR19T2,5	19	3	15,12	90	120
BAR20T2,5	20	3	15,92	90	120
BAR21T2,5	21	3	16,71	90	120
BAR22T2,5	22	3	17,51	125	140
BAR24T2,5	24	3	19,10	125	140
BAR26T2,5	26	3	20,69	125	140
BAR27T2,5	27	3	21,49	125	140
BAR28T2,5	28	3	22,28	125	140
BAR29T2,5	29	3	23,08	125	140
BAR30T2,5	30	3	23,87	125	140
BAR32T2,5	32	3	25,46	125	140
BAR34T2,5	34	3	27,06	125	140
BAR35T2,5	35	3	27,85	132	140
BAR36T2,5	36	3	28,65	132	140
BAR38T2,5	38	3	30,24	132	140
BAR40T2,5	40	3	31,83	132	140
BAR42T2,5	42	3	33,42	140	140
BAR44T2,5	44	3	35,01	140	140
BAR45T2,5	45	3	35,81	140	140
BAR48T2,5	48	3	38,20	140	140
BAR50T2,5	50	3	39,79	160	160
BAR60T2,5	60	3	47,75	160	160
BAR65T2,5	65	3	51,73	160	160
BAR70T2,5	70	3	55,70	160	160
BAR72T2,5	72	3	57,30	160	160
BAR90T2,5	90	3	71,62	160	160
BAR100T2,5	100	3	79,58	160	160

T 5 (pas 5 mm)					
ALUMINUM					
Code	Nb de dents.	Type	R [mm]	Lu [mm]	L [mm]
BAR10T5	10	1	15,91	140	140
BAR11T5	11	1	17,5	140	140
BAR12T5	12	1	19,1	140	140
BAR13T5	13	1	20,69	140	140
BAR14T5	14	1	22,28	140	140
BAR15T5	15	1	23,87	140	140
BAR16T5	16	1	25,47	140	140
BAR17T5	17	1	27,06	140	140
BAR18T5	18	1	28,65	140	140
BAR19T5	19	1	30,24	140	140
BAR20T5	20	1	31,83	160	160
BAR21T5	21	1	33,42	160	160
BAR22T5	22	1	35,01	160	160
BAR23T5	23	1	36,61	160	160
BAR24T5	24	1	38,19	160	160
BAR25T5	25	1	39,79	160	160
BAR26T5	26	1	41,38	160	160
BAR27T5	27	1	42,97	160	160
BAR28T5	28	1	44,56	160	160
BAR29T5	29	1	46,16	160	160
BAR30T5	30	1	47,15	160	160
BAR32T5	32	1	50,93	160	160
BAR34T5	34	1	54,11	160	160
BAR35T5	35	1	55,71	160	160
BAR36T5	36	1	57,3	160	160
BAR37T5	37	1	58,89	160	160
BAR38T5	38	1	60,48	160	160
BAR40T5	40	1	63,66	160	160
BAR42T5	42	1	68,85	160	160
BAR44T5	44	1	70,03	160	160
BAR45T5	45	1	71,62	160	160
BAR46T5	46	1	73,21	160	160
BAR48T5	48	1	76,39	160	160
BAR50T5	50	1	79,58	160	160
BAR60T5	60	1	95,49	160	160
BAR72T5	72	1	114,59	160	160
BAR80T5	80	1	127,32	160	160
BAR90T5	90	1	143,24	160	160
BAR100T5	100	1	159,15	160	160

T 10 (pas 10 mm)					
ALUMINUM					
Code	Nb de dents.	Type	R [mm]	Lu [mm]	L [mm]
BAR10T10	10	1	31,83	140	140
BAR11T10	11	1	35,01	140	140
BAR12T10	12	1	38,19	140	140
BAR13T10	13	1	41,38	140	140
BAR14T10	14	1	44,56	160	160
BAR15T10	15	1	47,74	160	160
BAR16T10	16	1	50,93	160	160
BAR17T10	17	1	54,11	160	160
BAR18T10	18	1	57,29	160	160
BAR19T10	19	1	60,47	160	160
BAR20T10	20	1	63,66	160	160
BAR21T10	21	1	66,84	160	160
BAR22T10	22	1	70,02	160	160
BAR23T10	23	1	73,21	160	160
BAR24T10	24	1	76,39	160	160
BAR26T10	26	1	82,76	160	160
BAR28T10	28	1	89,12	160	160
BAR30T10	30	1	95,49	160	160
BAR32T10	32	1	101,85	160	160
BAR34T10	34	1	108,22	160	160
BAR36T10	36	1	114,59	160	160
BAR38T10	38	1	120,95	160	160
BAR40T10	40	1	127,32	160	160
BAR45T10	45	1	143,23	160	160
BAR48T10	48	1	152,78	160	160
BAR60T10	60	1	190,98	160	160
BAR72T10	72	1	229,17	160	160

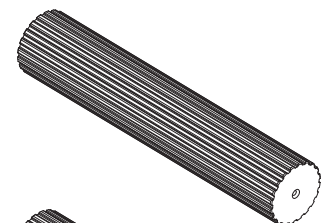

1

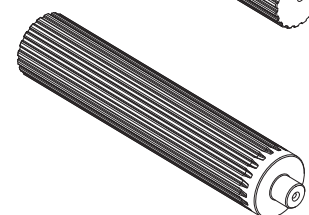

3

Désignation	BAR 22 T10 / AL
Barreau denté	
Nombre de dents	
Pas	
Matière - AL: aluminum	

Types AT 5 - AT 10

Les barreaux dentés "AT" sont en aluminium 6082 adapté aux traitements d'anodisation dure

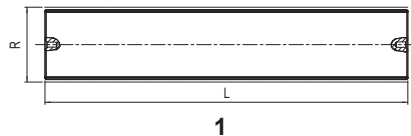

Désignation	BAR 28 AT10 / AL
Barreau denté	
Nombre de dents	
Pas	
Matière - AL: aluminum	

Dimensions

AT 5 (pas 5 mm)					
ALUMINUM					
Code	Nb de dents.	Type	R [mm]	Lu [mm]	L [mm]
BAR12AT5	12	1	19,1	140	140
BAR13AT5	13	1	20,69	140	140
BAR14AT5	14	1	22,28	140	140
BAR15AT5	15	1	23,87	140	140
BAR16AT5	16	1	25,47	140	140
BAR17AT5	17	1	27,06	140	140
BAR18AT5	18	1	28,65	140	140
BAR19AT5	19	1	30,24	140	140
BAR20AT5	20	1	31,83	160	160
BAR21AT5	21	1	33,42	160	160
BAR22AT5	22	1	35,01	160	160
BAR23AT5	23	1	36,61	160	160
BAR24AT5	24	1	38,19	160	160
BAR25AT5	25	1	39,79	160	160
BAR26AT5	26	1	41,38	160	160
BAR27AT5	27	1	42,97	160	160
BAR28AT5	28	1	44,56	160	160
BAR29AT5	29	1	46,16	160	160
BAR30AT5	30	1	47,75	160	160
BAR31AT5	31	1	49,34	160	160
BAR32AT5	32	1	50,93	160	160
BAR33AT5	33	1	52,52	160	160
BAR34AT5	34	1	54,11	160	160
BAR35AT5	35	1	55,71	160	160
BAR36AT5	36	1	57,3	160	160
BAR38AT5	38	1	60,48	160	160
BAR40AT5	40	1	63,66	160	160
BAR42AT5	42	1	66,85	160	160
BAR44AT5	44	1	70,03	160	160
BAR45AT5	45	1	71,62	160	160
BAR46AT5	46	1	73,21	160	160
BAR48AT5	48	1	76,39	160	160
BAR50AT5	50	1	79,58	160	160
BAR52AT5	52	1	82,76	160	160
BAR54AT5	54	1	85,94	160	160
BAR55AT5	55	1	87,54	160	160
BAR56AT5	56	1	89,13	160	160
BAR58AT5	58	1	92,31	160	160
BAR60AT5	60	1	95,49	160	160
BAR62AT5	62	1	98,68	160	160
BAR64AT5	64	1	101,86	160	160
BAR65AT5	65	1	103,45	160	160
BAR70AT5	70	1	111,41	160	160
BAR72AT5	72	1	114,59	160	160

AT 10 (pas 10 mm)					
ALUMINUM					
Code	Nb de dents.	Type	R [mm]	Lu [mm]	L [mm]
BAR14AT10	14	1	44,56	160	160
BAR15AT10	15	1	47,75	160	160
BAR16AT10	16	1	50,93	160	160
BAR17AT10	17	1	54,11	160	160
BAR18AT10	18	1	57,30	160	160
BAR19AT10	19	1	60,48	160	160
BAR20AT10	20	1	63,66	160	160
BAR21AT10	21	1	66,85	160	160
BAR22AT10	22	1	70,03	160	160
BAR23AT10	23	1	73,21	160	160
BAR24AT10	24	1	76,39	160	160
BAR25AT10	25	1	79,58	160	160
BAR26AT10	26	1	82,76	160	160
BAR27AT10	27	1	85,94	160	160
BAR28AT10	28	1	89,13	160	160
BAR29AT10	29	1	92,31	160	160
BAR30AT10	30	1	95,49	160	160
BAR31AT10	31	1	98,68	160	160
BAR32AT10	32	1	101,86	160	160
BAR33AT10	33	1	105,04	160	160
BAR34AT10	34	1	108,23	160	160
BAR35AT10	35	1	111,41	160	160
BAR36AT10	36	1	114,59	160	160
BAR37AT10	37	1	117,77	160	160
BAR38AT10	38	1	120,96	160	160
BAR40AT10	40	1	127,32	160	160
BAR41AT10	41	1	130,51	160	160
BAR42AT10	42	1	133,69	160	160
BAR44AT10	44	1	140,06	160	160
BAR45AT10	45	1	143,24	160	160
BAR46AT10	46	1	146,42	160	160
BAR48AT10	48	1	152,79	160	160
BAR50AT10	50	1	159,15	160	160
BAR51AT10	51	1	162,34	160	160
BAR52AT10	52	1	165,52	160	160
BAR54AT10	54	1	171,89	160	160
BAR55AT10	55	1	175,07	160	160
BAR56AT10	56	1	178,25	160	160
BAR57AT10	57	1	181,44	160	160
BAR58AT10	58	1	184,62	160	160
BAR59AT10	59	1	187,80	160	160
BAR60AT10	60	1	190,99	160	160
BAR62AT10	62	1	197,35	160	160
BAR70AT10	70	1	222,82	160	160

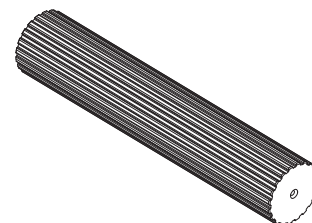

Flasques



Matière : P11 UNI EN 10111 (Sur demande, flasques en acier inoxydable et en aluminium.)
 Finition : Galvanisation
 Processus de production : Découpage

Flasques spéciales selon les normes SIT.

Les poulies présentées dans ce catalogue n'utilisent pas nécessairement ces flasques spéciales.

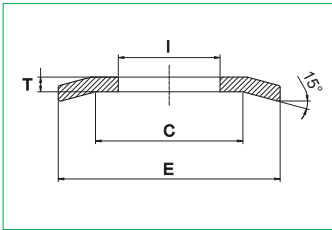

Désignation	FL - 7 SP1,5 ZN
Flasque	
Taille	
Épaisseur	
Galvanisé	

Dimensions des flasques spéciales aux normes SIT.

Type de flasque	Diamètre interne I [mm]	Diamètre C [mm]	Diamètre externe E [mm]	Épaisseur flasque T [mm]	Nombre de dents / poulie						Épaisseur flasque T [mm]	3 mm ST - RP - HD	Épaisseur flasque T [mm]	Nombre de dents / poulie						
					XL	L	H	XH	XXH	T20				8 mm ST - RP - HD - PBG	14mm ST - RP - HD - PBG	4,5 mm ST - RP - HD	5 mm ST - RP - HD	T2,5	T5 - AT5	T10 - AT10
0/0	6,5	-	12	0,6								0,5	10	1			12-13			
0/1	8,5	-	16	1								0,5	12-13	1			14-15			
0/2	10	-	18	1								0,5	14	1			16-18	10		
0/3	12,5	-	21,5	1								0,5		1	12		19			
0/4	9	-	16	1								0,5	15	1						
0/5	13	-	19	0,5								0,5		1						
1	13	17	20	1	10-11							0,5	16-19	1	13		20-22	11		
1/1	15	19	23	1								0,5	20	1		12	24	12		
2	16	21	24	1	12-13							0,5	21	1	14-15	14	25-26	14		
2/1	17	22	25	1								0,5	22-23	1						
3	19	24	27	1	14-15							0,5	24 spec.	1	16-17	15-16	28-30	15		
3/1	21	26,5	29,5	1								0,5		1						
3/2	19	22	25	0,5								0,5	24-26	-						
4	22	27	30	1	16-17							0,5	27-29	1	18-19	17-18	32-34	16-18		
4/1	22	30	33	1								0,5		1						
5	25	30	33	1,5	18	10						0,5	30-32	1	20-21	20	35-37	19-20		
5/1	28		34	0,5								0,5		-						
6	28	32	36	1,5	19-20	11						0,5	33-35	1	22-23	21-22	38-40	21-22		
6/1	31		36	1,5								0,5		1						
7	31	36	40	1,5	21-22-23	12						0,5	36-39	1	25-26	24	42-44	24	12	
7/1	31	40	47	1,5		13				16-17		0,5		1	27-28					13
7/2	31	40	42	-								-		1				24		
8	35	42	46	1,5	24-25-26	14						0,5	40-44	1	29	26	25-27	14		
8/1	36	45	50	1,5							18	0,5		1	30-31					
8/2	35	42	44	1								0,5		1						
8/3	37	48	43	1,5								-		-						
9	39	46	50	1,5	27-28-29	15	12				19	0,5		1	32-33	28-30		28-30	15	
9/1	41	50	55	1,5							20	0,5		1	34					
9/2	39	46	51	1,5							20	0,5		1				30		
9/3	41	46	51	-							20	0,5		1				30		
10	43	48	55	1,5	30	16-17					21	0,5		1	35-36	32		31-33	16	
10/1	47	52	57	1,5	32							0,5		1		34				
10/2	43	48	54	1								0,5		1						
10/3	46	51	57	1,5								-		-						
11	47	55	62	1,5	35-36	18-19	14				22-23	0,5		1	37-38	36		34-36	17-18	
11/1	51	61	67	1,5			15				24	0,5	64	1	39-40	38				
11/2	47	55	60	1,5							22	0,5		-						
12	53	60	67	1,5		20-21	16				25	0,5		1	41	40		37-40	19-20	
13	56	65	73	1,5	40-42	22-23					26-27	0,5		1		44		41-42	21-22	
13/1	60	70	77	1,5	44		17				28	0,5		1						23
13/2	60	73	79	1,5								-		-						
13/3	56	65	70	1,5							26	-		-						
13/4	57	68	75	1,5							28	-		-						

Type de flasque	Diamètre interne I [mm]	Diamètre C [mm]	Diamètre externe E [mm]	Épaisseur flasque T [mm]	Nombre de dents / poulie							Épaisseur flasque T [mm]	3 mm ST - RP - HD	Épaisseur flasque T [mm]	Nombre de dents / poulie				
					XL	L	H	XH	XXH	T20	8 mm ST - RP - HD - PBG				14mm ST - RP - HD - PBG	4,5 mm ST - RP - HD	5 mm ST - RP - HD	T2,5	T5 - AT5
14	64	72	80	1,5		24-25	18				29		-	1					24
14/1	71	77,3	80	-									-	1				48	
14/2	71	77,3	79,5	-									-	1				48	
15	68	79	84	1,5	48		19				30-31		-	1		48		25	
16	71	80	88	1,5		26-27	20				32-33		-	1				26-27	
16/1	75	84	90	1,5									-	1					
16/2	75	88	94	1,5							34		-	-					
17	78	88	94	1,5	52	28-29	21-22				35		-	1		56		28-29	
18	80	90	98	1,5	57	30	23				36		-	1				30	
19	83	94	100	1,5		31-32					37		-	1			60	31	
20	88	96	104	1,5			24-25				38-39		-	1		60			
20/1	90	101	108	1,5	60	33					40		-	1		64			
20/2	92,6	100,5	106	3							40		-	1					
21	93	102	108	1,5		34	26				41		-	1				32-33	
21/1	94	106	111	1,5							42		-	1				66	
22	96	105	113	1,5		35-36	27				43		-	1			68	34-35	
23	102	112	118	1,5		37	28						-	1				36	
24	104	113	121	1,5	72	38-39	29				44-45		-	1				37	
24/1	105	120	127	1,5							46-47		-	1				38	
25	108	125	134	2,5				18	20		28-29		-	1					
26	112	121	129	1,5		40-41	30				48-49		-	1				39-40	
26/1	115	126	131	1,5			31				50		-	1					
27	115	132	142	2,5				19			30		-	1					
28	120	128	137	1,5		42-43	32-33				51-52		-	1					
29	122	138	150	2,5				20	22		31-32		-	1					
30	126	136	142	1,5		44-45	34				53-54		-	1			86		
31	130	140	145	1,5		46	35				55		-	-					
32	130	146	158	2,5				21	24		33-34		-	-					
33	134	141	149	1,5		47					56-57		-	-					
34	135	145	151	1,5		48	36				58		-	-					
34/1	142	154	158	1,5		49	37				60-61		-	-					
35	136	153	166	2,5				22-23	25		35-36		-	-					
36	143	152	158	1,5		50-51	38						-	-					
36/1	146	158	166	1,5		52	39				62		-	-					
37	149	167	177	2,5				24			37-38		-	-					
38	151	160	168	1,5		53-54	40				64-65		-	-					
39	156	176	186	2,5				25	18		39-40		-	-					
40	158	167	175	1,5		55-56	41-42				66-67		-	-					
40/1	161	176	182	1,5							68-70		-	-					
41	165	181	191	2,5				26			41-42		-	-					
42	166	176	182	1,5		57-58	43						-	-					
42/1	170	184	191	1,5			44				71-72		-	-					
43	166	188	200	2,5				27	19	30	43		-	-					
44	172	177	189	1,5		59-60	45-46						-	-					
45	177	197	209	2,5					20	32	44-45		-	-					
46	182	193	199	1,5			47-48	28					-	-					
47	180	195	202	1,5			49-50						-	-					
48	194	210	216	2,5			51-52-53	30	21		48		-	-					
49	208	224	232	2,5			54-55-56	32	22		50		-	-					
49/1	210	-	240	2,5							51-52		-	-					
50	222	238	266	2,5			57-58-59	34	24		54-55		-	-					
51	232	252	261	2,5			60-61	36	25		56-57		-	-					
51/1	238	261	272	2,5			62-63		26		58-59		-	-					
52	250	266	274	2,5			64-65-66	38			60		-	-					
52/1	260	277	288	2,5			67-68	40	28		62		-	-					
53	264	280	288	2,5		90	69-70				63-64		-	-					
54	284	-	325	1,5									-	-					
55	285	-	333	3							72		-	-					
56	322	-	369	3							80		-	-					

Plaques de jonction



Les plaques de jonction peuvent être utilisées comme fixations aux extrémités de la courroie dans de nombreux entraînements linéaires.

Les plaques de jonction doivent avoir un profil adapté à la courroie, pour garantir une force de serrage uniforme sur toute la surface de la courroie, et être rigides. En utilisation standard, un minimum de 7 dents en prise est recommandé.

Pour une utilisation avec des courroies comportant des câbles de tensions spéciaux (par exemple HPL), un minimum de 12 dents en prise est recommandé, une version spéciale est alors, nécessaire.

Les plaques de jonction peuvent être revêtues ou brutes.

Matière standard : aluminium.

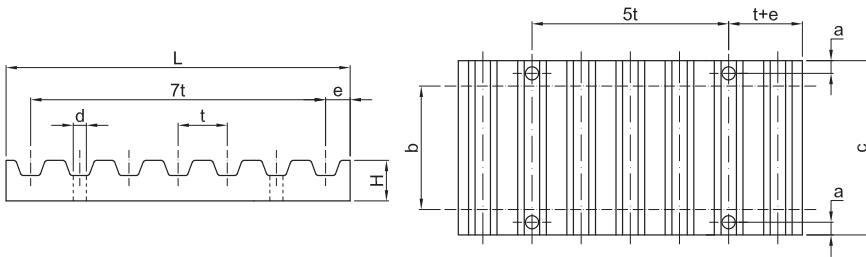

Désignation	PIA -TS	/10
Plaques de jonction		
Pas		
Largeur de la courroie (en mm ou en pouces x 10)		

Type	a [mm]	d [mm]	e [mm]	L [mm]	H [mm]	Largeur de la courroie [mm]							
						6	10	16	25	32	50	75	100
C													
T5	6	5,5	3,2	41,8	8	-	29	35	44	-	-	-	-
AT5	6	5,5	3,2	41,8	8	-	29	35	44	-	-	-	-
T10	8	9	5	80	15	-	-	41	50	57	75	100	125
AT10	8	9	5	80	15	-	-	41	50	57	75	100	125
T20*	10	11	10	160	20	-	-	-	56	63	81	106	132
AT20*	10	11	10	160	20	-	-	-	56	63	81	106	132

*= sur demande

Type	a [mm]	d [mm]	e [mm]	L [mm]	H [mm]	Largeur de la courroie [pouce/100]							
						025	032	037	050	075	100	150	200
C [mm]													
XL	6	5,5	3,5	42,5	8	25,5	27	28,5	-	-	-	-	-
L	8	9	6	76,6	15	-	-	36	39	45	51,5	64	77
H	10	11	9	106,9	22	-	-	-	45	51	57,5	70	83

Type	a [mm]	d [mm]	e [mm]	L [mm]	H [mm]	Largeur de la courroie [mm]									
						15	20	25	30	40	50	55	85	115	
C [mm]															
3M	5	4,5	2	25	5	21	24	30	-	-	-	-	-	-	-
5M	6	5,5	3,4	41,8	8	34	-	44	-	-	-	-	-	-	-
8M	8	9	5	66	15	40	45	-	55	-	75	-	110	-	-
14M	10	11	9	116	22	-	-	56	-	71	-	86	116	146	-

Courroies EAGLE	Plaque de jonction					Largeur de la courroie [mm]										
	Pas	b	d	f	Length [mm]	H	12,5	25	16	25	32	50	35	52,5	70	105
							Largeur d'une plaque de jonction [mm]									
EAGLE 5	6	5,5	8,5	47	7,5	30	-	-	-	-	-	-	-	-	-	-
	7					-	45	-	-	-	-	-	-	-	-	-
EAGLE 8	7,5	9	13	74	14,5	-	-	40	-	-	-	-	-	-	-	-
	8					-	-	-	50	57	75	-	-	-	-	-
EAGLE 10	8	9	17	94	14,5	-	-	-	50	57	75	-	-	-	-	-
	10					-	-	-	-	-	-	-	65	82,5	100	-
EAGLE 14	9,5	11	23	130	22	-	-	-	-	-	-	-	-	-	-	-
	10					-	-	-	-	-	-	-	-	-	-	-

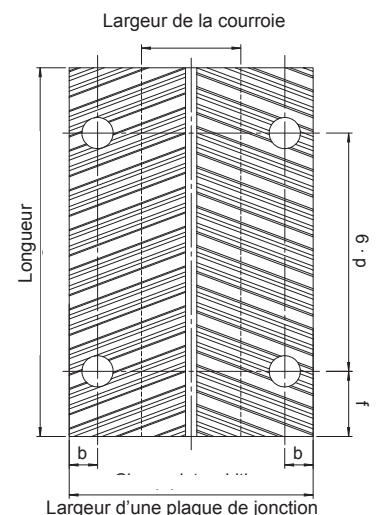
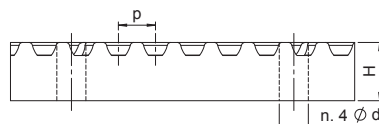

Plaques de jonction brutes SIT

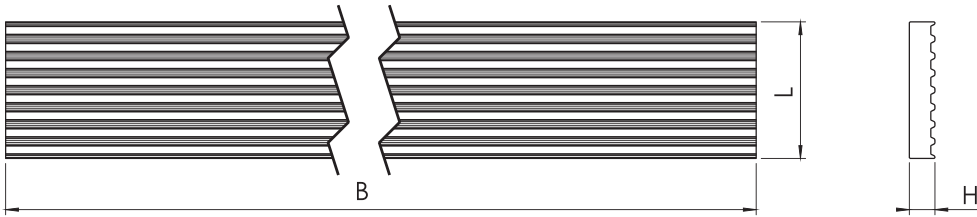

Type	B [mm]	H [mm]	L [mm]
T5	750	8	41,8
AT5	750	8	41,8
T10	750	15	80,0
AT10	750	15	80,0

Type	B [mm]	H [mm]	L [mm]
XL	750	8	42,5
L	750	15	76,6
H	750	22	106,9

Type	B [mm]	H [mm]	L [mm]
3M	750	5	25,0
5M	750	8	41,8
8M	750	15	66,0
14M	750	15	116,0

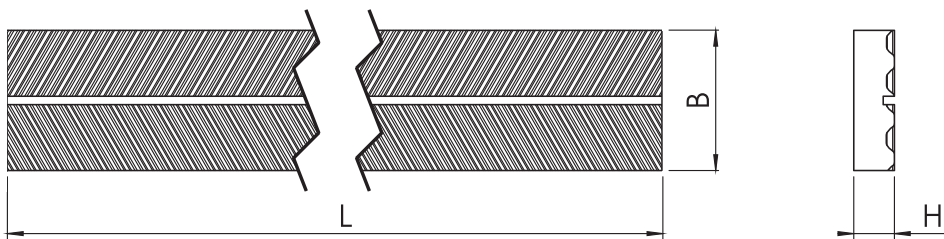

Courroies EAGLE	Plaque de jonction															
	Pas	L [mm]	H [mm]	Code												
PIA-E5/12,5				PIA-E5/25	PIA-E8/16-Y	PIA-E8/25-M	PIA-E8/32-W	PIA-E8/50-L	PIA-E10/25	PIA-E10/32	PIA-E10/50	PIA-E10/75	PIA-E14/35-B	PIA-E14/52,5-G	PIA-E14/70-O	PIA-E14/105-R
B [mm]																
EAGLE 5	710	7,5	30	45	-	-	-	-	-	-	-	-	-	-	-	-
EAGLE 8	730	14,5	-	-	40	50	57	75	-	-	-	-	-	-	-	-
EAGLE 10	710	14,5	-	-	-	-	-	-	50	57	75	100	-	-	-	-
EAGLE 14	710	22	-	-	-	-	-	-	-	-	-	-	65	82,5	100	136

Désignation

PIA -T5 -S

Plaque de jonction

Pas

Exécution brute

(Note :

pour le type Eagle, spécifiez la largeur de la courroie)

Poulies à gorges trapézoïdales



Poulies à gorges trapézoïdales SIT

Sur le marché, il existe différents types de **courroies trapézoïdales**, dont les plus répandus sont:

- "étroite" SPZ-SPA-SPB-SPC (ISO4184 - DIN 7753)
- "classique" Z-A-B-C (ISO 4184 - DIN 2215)
- "étroite américaine" 3V-5V (RMA-MPTA).

Les poulies à gorges trapézoïdales "étroite" (DIN2211 - ISO4183) fabriquées par SIT et présentées dans ce catalogue conviennent à tous les types de courroies précitées.

Note : Les courroies 3V - 5V - 8V utilisent des poulies avec des spécifications RMA (réf. Pag. 100). Ces poulies ne sont pas standard et ne sont disponibles que sur demande.

Tableau de compatibilité entre les types de courroies trapézoïdales et les poulies à gorges trapézoïdales SIT.

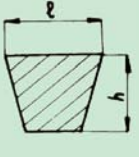
		Courroies trapézoïdales										
		ISO 4184 - DIN 7753/1				RMA - MPTA			ISO 4184 - DIN 2215			
		SPZ	SPA	SPB	SPC	3V	5V	8V	Z	A	B	C
a x b	9,7 x 8	12,7 x 10	17 x 13	22 x 18	9,5 x 8	16 x 13,5	25,5 x 23	10 x 6	13 x 8	17 x 11	22 x 14	
Poulies SIT (DIN 2211)												
PT	SPZ	○										
	SPA	-	.	-	-	-	-	-	-	○	-	-
	SPB	-	-	○	-	-	○*	-	-	-	○	-
	C	-	-	-	X	-	-	-	-	-	-	○
PBT	SPZ	○	-	-	-	○*	-	-	○	-	-	-
	SPA	-	○	-	-	-	-	-	-	○	-	-
	SPB	-	-	○	-	-	○*	-	-	-	○	-
	SPC	-	-	-	○	-	-	-	-	-	-	○
PCT	SPZ	○	-	-	-	○*	-	-	○	-	-	-
	SPA	-	○	-	-	-	-	-	-	○	-	-
	SPB	-	-	○	-	-	○*	-	-	-	○	-
	SPC	-	-	-	○	-	-	-	-	-	-	○

○ = COMPATIBLE
X = INCOMPATIBLE

* Le pas entre les gorges de la poulie SPZ est différent du 3V. De même, le pas est également différent entre SPB et 5V.

Poulies à gorges trapézoïdales SIT - Type de poulies

Poulie PT - moyeu plein

Matière : fonte. DIN 1691 GG-20/GG25

Finition: phosphatation au manganèse noir.

Poulies trapézoïdales adaptées à un usage normal avec les courroies suivantes :

- SPZ-Z-3V
- SPA-A
- SPB-B-5V
- C



Poulie PBT - pour moyeux amovibles SER-SIT®

Matière : fonte. DIN 1691 GG-20/GG25

Finition: phosphatation au manganèse noir.

Poulies trapézoïdales adaptées aux courroies suivantes :

- SPZ-Z-3V
- SPA-A
- SPB-B-5V
- SPC-C



Poulie PCT - avec moyeu surdimensionné pour moyeux de serrage

Matière : fonte. DIN 1691 GG-20/GG25

Finition: phosphatation au manganèse noir..

Poulies trapézoïdales adaptées aux courroies suivantes :

- SPZ-Z-3V
- SPA-A
- SPB-B-5V
- SPC-C



Caractéristiques

Nos poulies peuvent être utilisées pour une application avec une vitesse allant jusqu'à 35 m / s.

Les dimensions de la poulie sont très précises puisqu'elles sont fabriquées par des tours CNC ou automatiques.

Pour une vitesse plus élevée, il est fortement recommandé d'utiliser l'acier comme matériau de construction.

Équilibrage

Nos poulies PBT sont statiquement équilibrées selon les normes ISO.

Les poulies PT ne sont pas équilibrées, car elles n'ont pas d'alésage fini.

TOLERANCES

dw [mm]	Tolérance de diamètre du pas[mm]	Tolérance d'excentricité correspondant au diamètre extérieur [mm]
50	± 0,4	0,2
56	± 0,4	
63	± 0,5	
71	± 0,6	
80	± 0,6	
90	± 0,7	
100	± 0,8	0,3
112	± 0,9	
118	± 1,0	
125	± 1,0	
135	± 1,0	
140	± 1,1	
150	± 1,2	0,4
160	± 1,3	
180	± 1,4	
190	± 1,5	
200	± 1,6	
212	± 1,7	
224	± 1,8	0,5
236	± 1,9	
250	± 2,0	
280	± 2,2	
300	± 2,4	
315	± 2,5	
355	± 2,8	0,6
400	± 3,2	
450	± 3,6	
500	± 4,0	
560	± 4,5	
630	± 5,0	
710	± 5,7	0,8
800	± 6,4	
900	± 7,2	
1000	± 8,0	
1120	± 9,0	
1250	± 10,0	

Différence maximum du diamètres de pas dans les gorges d'une même poulie [mm]

SPZ - SPA - SPB	SPC
0,4	0,6

Note

En raison de l'amélioration constante de nos produits, les données techniques des poulies peuvent faire l'objet de modifications.

Dimension des gorges (DIN 2211)

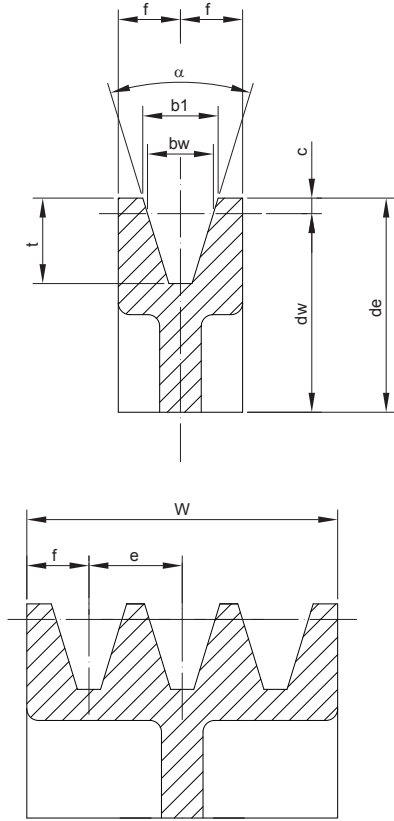

Section	SPZ [mm]	SPA [mm]	SPB [mm]	C/SPC [mm]	
b_w [mm]	8,5	11,0	14,0	19,0	
b_1 [mm] ($\pm 0,2$)	9,7	12,7	16,3	22,0	
c [mm]	2,0	2,8	3,5	4,8	
e [mm]	$12 \pm 0,3$	$15 \pm 0,3$	$19 \pm 0,4$	$25,5 \pm 0,5$	
f [mm]	$8 \pm 0,6$	$10 \pm 0,6$	$12,5 \pm 0,8$	17 ± 1	
t [mm] min.	$11^{+0,6}_0$	$13,8^{+0,6}_0$	$17,5^{+0,6}_0$	C: 20 SPC: $23,8^{+0,6}_0$	
34° par d_w [mm]	80	118	190	315	
38° par d_w [mm]	>80	>118	>190	>315	
Tolerance	$\pm 1^\circ$	$\pm 1^\circ$	$\pm 1^\circ$	$\pm 1^\circ$	
W Largeur de la couronne selon le nombre de gorges Z [mm]	Z = 1	16	20	25	34
	2	28	35	44	59,5
	3	40	50	63	85
	4	52	65	82	110
	5	64	80	101	136
	6	76	95	120	161,5
	7	88	110	139	187
	8	100	125	158	212,5
	9	112	140	177	238
	10	124	155	196	263,5
	11	136	170	215	289
	12	148	185	234	314,5

Dimension des gorges trapézoïdales des poulies pour les courroies (RMA)

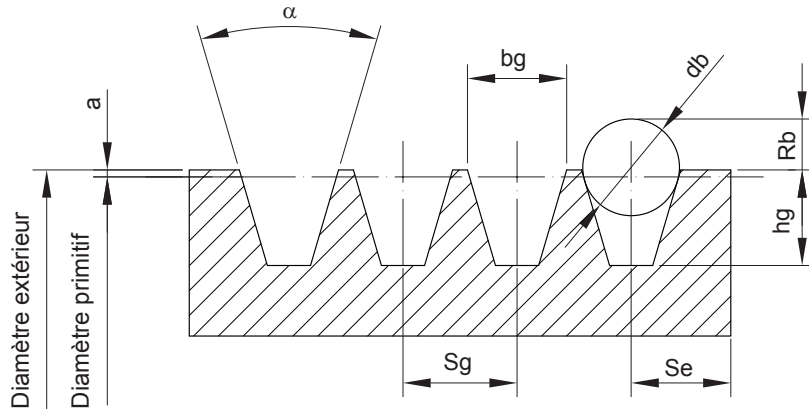

Section	D [mm]	α [°]	bg [mm]	hg min. [mm]	a [mm]	Rb min. [mm]	db [mm]	Sg [mm]	Se [mm]
3V	≤ 89	$36 \pm 0,25$	$8,89 \pm 0,13$	8,63	0,63	4,6	$8,73 \pm 0,01$	$10,3 \pm 0,4$	9^{+2}_{-1}
	90 ÷ 152	$38 \pm 0,25$	$8,89 \pm 0,13$	8,63	0,63	4,6	$8,73 \pm 0,01$	$10,3 \pm 0,4$	9^{+2}_{-1}
	153 ÷ 1305	$40 \pm 0,25$	$8,89 \pm 0,13$	8,63	0,63	4,7	$8,73 \pm 0,01$	$10,3 \pm 0,4$	9^{+2}_{-1}
	> 305	$42 \pm 0,25$	$8,89 \pm 0,13$	8,63	0,63	4,8	$8,73 \pm 0,01$	$10,3 \pm 0,4$	9^{+2}_{-1}
5V	≤ 254	$38 \pm 0,25$	$15,24 \pm 0,13$	14,98	1,27	8,4	$15,08 \pm 0,01$	$17,5 \pm 0,4$	13^{+3}_{-1}
	255 ÷ 406	$40 \pm 0,25$	$15,24 \pm 0,13$	14,98	1,27	8,4	$15,08 \pm 0,01$	$17,5 \pm 0,4$	13^{+3}_{-1}
	> 406	$42 \pm 0,25$	$15,24 \pm 0,13$	14,98	1,27	8,5	$15,08 \pm 0,01$	$17,5 \pm 0,4$	13^{+3}_{-1}
8V	≤ 406	$38 \pm 0,25$	$25,4 \pm 0,13$	25,14	2,54	14,6	$25,4 \pm 0,01$	$28,6 \pm 0,4$	19^{+6}_{-2}
	407 ÷ 569	$40 \pm 0,25$	$25,4 \pm 0,13$	25,14	2,54	14,7	$25,4 \pm 0,01$	$28,6 \pm 0,4$	19^{+6}_{-2}
	> 569	$42 \pm 0,25$	$25,4 \pm 0,13$	25,14	2,54	14,9	$25,4 \pm 0,01$	$28,6 \pm 0,4$	19^{+6}_{-2}

Dimensions des poulies à gorges trapézoïdales PT - moyeu plein

PT SPZ-Z-3V

ø primitif [mm]	Nb de gorges	Type	M [mm]	L [mm]	W [mm]	z [mm]
50	1	1	32*	28	16	12
	2	1	35*	35	28	7
	3	1	35*	44	40	4
	4	1	35*	56	52	4
56	1	1	32**	28	16	12
	2	1	40**	35	28	7
	3	1	42**	44	40	4
	4	1	42**	56	52	4
63	1	1	40	28	16	12
	2	1	40	35	28	7
	3	1	42	44	40	4
	4	1	42	56	52	4
71	1	1	40	28	16	12
	2	1	48	35	28	7
	3	1	50	44	40	4
	4	1	50	56	52	4
75	1	1	40	28	16	12
	2	1	50	35	28	7
	3	1	50	44	40	4
	4	1	50	56	52	4
80	1	4	40	28	16	12
	2	1	50	35	28	7
	3	1	50	44	40	4
	4	1	65	56	52	4
	5	1	65	68	64	4
85	1	4	40	28	16	12
	2	4	50	35	28	7
	3	1	50	44	40	4
	4	1	65	56	52	4
	5	1	65	68	64	4
90	1	4	40	28	16	12
	2	4	50	35	28	7
	3	4	50	44	40	4
	4	1	65	56	52	4
	5	1	68	68	64	4
95	1	4	45	28	16	12
	2	4	50	35	28	7
	3	4	50	40	40	-
	4	1	65	56	52	4
	5	1	68	68	64	4
100	1	4	45	28	16	12
	2	4	50	35	28	7
	3	4	60	40	40	-
	4	1	65	56	52	4
	5	1	68	68	64	4
106	1	4	45	28	16	12
	2	4	50	35	28	7
	3	4	60	40	40	-
	4	4	65	56	52	4
	5	4	68	68	64	4
112	1	4	45	28	16	12
	2	4	50	35	28	7
	3	4	60	40	40	-
	4	4	68	52	52	-
	5	5	68	60	64	4
118	1	4	45	28	16	12
	2	4	50	35	28	7
	3	4	60	40	40	-
	4	4	68	52	52	-
	5	5	75	60	64	4

* Note: Le diamètre en fond de gorge est de 32 mm
 ** Note: Le diamètre en fond de gorge est de 38 mm

» PT SPZ-Z-3V

ø primitif [mm]	Nb de gorges	Type	M [mm]	L [mm]	W [mm]	z [mm]
125	1	4	45	28	16	12
	2	4	50	35	28	7
	3	4	60	40	40	-
	4	4	68	52	52	-
	5	5	75	60	64	4
132	1	4	45	28	16	12
	2	4	60	40	28	12
	3	4	60	40	40	-
	4	4	68	52	52	-
	5	5	75	60	64	4
140	1	4	55	28	16	12
	2	4	60	40	28	12
	3	4	60	40	40	-
	4	4	68	52	52	-
	5	5	75	60	64	4
150	1	4	55	32	16	16
	2	4	60	40	28	12
	3	4	68	45	40	5
	4	4	68	52	52	-
	5	5	80	60	64	4
160	1	4	55	32	16	16
	2	4	60	40	28	12
	3	4	68	45	40	5
	4	4	68	52	52	-
	5	5	80	60	64	4
180	1	4	55	32	16	16
	2	4	65	40	28	12
	3	4	68	45	40	5
	4	4	80	52	52	-
	5	5	80	60	64	4
200	1	4A	55	32	16	16
	2	4A	65	40	28	12
	3	4A	68	45	40	5
	4	4A	80	52	52	-
	5	5A	80	60	64	4
224	1	8	55	32	16	16
	2	8	65	40	28	12
	3	8	68	45	40	5
	4	8	80	52	52	-
	5	9	80	60	64	4
250	1	8	55	32	16	16
	2	8	62	40	28	12
	3	8	68	45	40	5
	4	8	80	52	52	-
	5	9	88	60	64	4
280	1	8	68	45	16	29
	2	8	68	45	28	17
	3	8	80	50	40	10
	4	8	80	52	52	-
	5	9	96	60	64	4
315	1	8	68	45	16	29
	2	8	68	45	28	17
	3	8	80	50	40	10
	4	8	96	55	52	3
	5	9	96	60	64	4
355	1	8	68	45	16	29
	2	8	68	45	28	17
	3	8	80	50	40	10
	4	8	96	55	52	3
	5	9	96	60	64	4

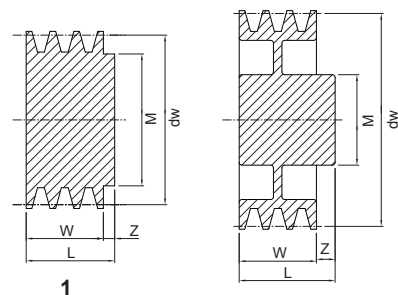
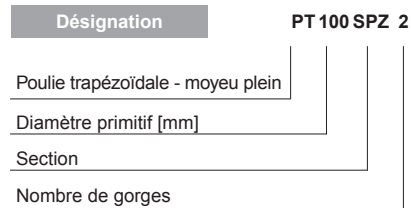

1

4

4A forme disque avec trous

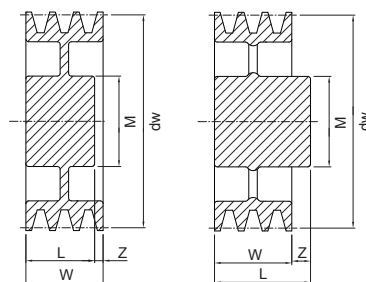

5

8 (3 bras)

5A forme disque avec trous

8A (6 bras)

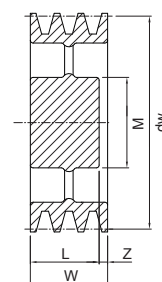

9

9A (3 bras)

9B (6 bras)

Dimensions des poulies à gorges trapézoïdales PT - moyeu plein



PT SPA-A

ø primitif [mm]	Nb de gorges	Type	M [mm]	L [mm]	W [mm]	z [mm]
50	1	1	32*	35	20	15
	2	1	40*	45	35	10
	3	1	40*	54	50	4
56	1	1	35**	35	20	15
	2	1	40**	45	35	10
	3	1	40**	54	50	4
63	1	1	40	35	20	15
	2	1	40	45	35	10
	3	1	40	54	50	4
	4	1	40	68	65	3
	5	1	40	84	80	4
71	1	1	40	35	20	15
	2	1	50	45	35	10
	3	1	52	54	50	4
	4	1	52	68	65	3
	5	1	52	84	80	4
75	1	1	40	35	20	15
	2	1	50	45	35	10
	3	1	52	54	50	4
	4	1	52	68	65	3
	5	1	52	84	80	4
80	1	1	45	35	20	15
	2	1	50	45	35	10
	3	1	62	54	50	4
	4	1	62	68	65	3
	5	1	62	84	80	4
85	1	4	45	35	20	15
	2	1	50	45	35	10
	3	1	62	54	50	4
	4	1	62	68	65	3
	5	1	62	84	80	4
90	1	4	45	35	20	15
	2	1	60	45	35	10
	3	1	62	54	50	4
	4	1	68	68	65	3
	5	1	68	84	80	4
95	1	4	45	35	20	15
	2	1	60	45	35	10
	3	1	62	54	50	4
	4	1	68	68	65	3
	5	1	68	84	80	4
100	1	4	45	35	20	15
	2	1	60	45	35	10
	3	1	62	54	50	4
	4	2	70	50	65	15
	5	2	70	50	80	30
106	1	4	45	35	20	15
	2	4	60	45	35	10
	3	4	60	50	50	-
	4	2	68	50	65	15
	5	2	68	50	80	30
112	1	4	45	35	20	15
	2	4	60	45	35	10
	3	4	60	50	50	-
	4	2	68	50	65	15
	5	2	68	50	80	30
118	1	4	60	35	20	15
	2	4	60	45	35	10
	3	4	70	50	50	-
	4	2	70	50	65	15
	5	2	80	50	80	30

» PT SPA-A

ø primitif [mm]	Nb de gorges	Type	M [mm]	L [mm]	W [mm]	z [mm]
125	1	4	55	35	20	15
	2	4	60	45	35	10
	3	4	68	50	50	-
	4	5	68	50	65	15
	5	5	80	50	80	30
132	1	4	55	35	20	15
	2	4	60	45	35	10
	3	4	68	50	50	-
	4	5	68	50	65	15
	5	5	80	50	80	30
140	1	4	60	35	20	15
	2	4	60	45	35	10
	3	4	68	50	50	-
	4	5	68	50	65	15
	5	5	80	50	80	30
150	1	4	60	40	20	20
	2	4	60	45	35	10
	3	4	68	50	50	-
	4	5	68	50	65	15
	5	5	80	50	80	30
160	1	4	60	40	20	20
	2	4	60	45	35	10
	3	4	68	50	50	-
	4	5	80	50	65	15
	5	5	80	50	80	30
170	1	4	60	40	20	20
	2	4	60	45	35	10
	3	4	68	50	50	-
	4	5	80	50	65	15
	5	5	80	50	80	30
180	1	4	65	40	20	20
	2	4	68	50	35	15
	3	4	68	50	50	-
	4	5	80	60	65	5
	5	5	80	65	80	15
190	1	4	65	40	20	20
	2	4	68	50	35	15
	3	4	68	50	50	-
	4	5	80	60	65	5
	5	5	80	65	80	15
200	1	4	65	40	20	20
	2	4	68	50	35	15
	3	4	75	50	50	-
	4	5	88	60	65	5
	5	5	88	65	80	15
224	1	4	65	40	20	20
	2	4	68	50	35	15
	3	4	75	50	50	-
	4	5	88	60	65	5
	5	5	88	65	80	15
236	1	4	68	40	20	20
	2	4	68	50	35	15
	3	4	75	50	50	-
	4	5	88	60	65	5
	5	5	88	65	80	15
250	1	8	75	50	20	30
	2	8	75	50	35	15
	3	8	75	50	50	-
	4	9	88	60	65	5
	5	9	96	65	80	15

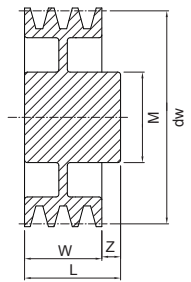
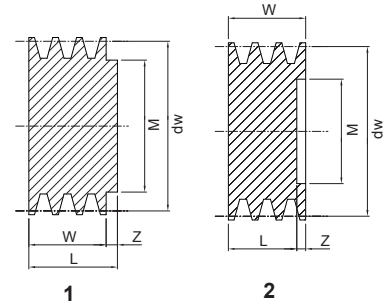

4A forme disque avec trous

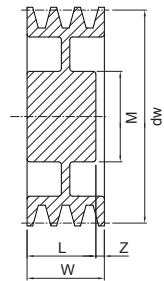

5A forme disque avec trous

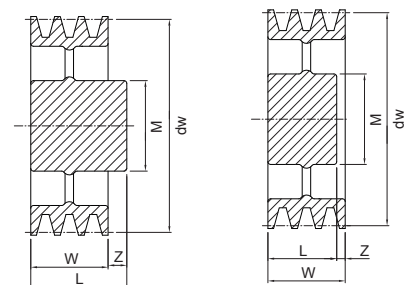

8 (3 bras)

8A (6 bras)

9 (3 bras)

9A (6 bras)

* Note: Le diamètre en fond de gorge est de 32 mm
 ** Note: Le diamètre en fond de gorge est de 34 mm

Dimensions des poulies à gorges trapézoïdales PT - moyeu plein



» PT SPA-A

ø primitif [mm]	Nb de gorges	Type	M [mm]	L [mm]	W [mm]	z [mm]
280	1	8	68	50	20	30
	2	8	75	50	35	15
	3	8	75	50	50	-
	4	9	88	60	65	5
	5	9	96	65	80	15
300	1	8	75	50	20	30
	2	8	75	50	35	15
	3	8	88	60	50	10
	4	9	88	60	65	5
	5	9	96	70	80	10
315	2	8	75	50	35	15
	3	8	88	60	50	10
	4	9	88	60	65	5
	5	9	96	70	80	10
	355	2	8	88	60	35
3		8	88	60	50	10
4		9	88	60	65	5
5		9	96	70	80	10
400		1	8A	78	50	20
	2	8A	88	60	35	25
	3	8A	96	65	50	15
	4	8A	96	65	65	-
	5	9A	96	70	80	10
450	2	8A	88	60	35	25
	3	8A	96	65	50	15
	4	8A	104	70	65	5
	5	9A	104	70	80	10
	500	2	8A	88	60	35
3		8A	96	65	50	15
4		8A	104	70	65	5
5		9A	104	70	80	10
560		2	8A	88	60	35
	3	8A	96	65	50	15
	4	8A	104	70	65	5
	5	9A	104	70	80	10
	630	3	8A	104	65	50
4		8A	112	70	65	5
5		9A	120	75	80	5
800	3	8A	128	100	50	50
	4	8A	128	100	65	35
	5	8A	145	110	80	30

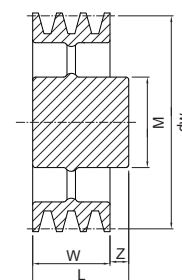

8 (3 bras)

8A (6 bras)

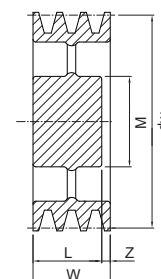

9

9A (3 bras)

Dimensions des poulies à gorges trapézoïdales PT - moyeu plein



PT SPB-B-5V

ø primitif [mm]	Nb de gorges	Type	M [mm]	L [mm]	W [mm]	z [mm]
60	1	1	40	35*	25	10
	2	1	40	48*	44	4
71	1	1	45	35**	25	10
	2	1	45	48**	44	4
	3	1	45	67**	63	4
75	1	1	45	35	25	10
	2	1	45	48	44	4
	3	1	45	67	63	4
80	1	1	50	35	25	10
	2	1	50	48	44	4
	3	1	50	67	63	4
	4	1	52	86	82	4
	5	1	58	105	101	4
85	1	1	50	35	25	10
	2	1	50	48	44	4
	3	1	52	67	63	4
	4	1	58	86	82	4
	5	1	58	105	101	4
90	1	1	50	35	25	10
	2	1	50	48	44	4
	3	1	58	67	63	4
	4	2	65	50	82	32
	5	2	65	50	101	51
95	1	1	52	35	25	10
	2	1	55	48	44	4
	3	1	58	67	63	4
	4	2	65	50	82	32
	5	2	65	50	101	51
100	1	1	52	35	25	10
	2	1	55	48	44	4
	3	1	58	67	63	4
	4	2	65	50	82	32
	5	2	65	50	101	51
106	1	4	50	35	25	10
	2	4	55	48	44	4
	3	2	65	50	63	13
	4	2	65	50	82	32
	5	2	67	50	101	51
112	1	4	55	35	25	10
	2	4	60	48	44	4
	3	2	65	50	63	13
	4	2	75	50	82	32
	5	2	75	50	101	51
118	1	4	55	35	25	10
	2	4	60	48	44	4
	3	2	75	50	63	13
	4	2	75	50	82	32
	5	2	75	50	101	51
125	1	4	55	35	25	10
	2	4	60	48	44	4
	3	5	75	50	63	13
	4	5	75	50	82	32
	5	5	75	50	101	51
	6	2	80	60	120	60
132	1	4	60	35	25	10
	2	4	60	50	44	6
	3	5	75	50	63	13
	4	5	80	50	82	32
	5	5	80	60	101	41
	6	5	80	60	120	60

» PT SPB-B-5V

ø primitif [mm]	Nb de gorges	Type	M [mm]	L [mm]	W [mm]	z [mm]
140	1	4	60	35	25	10
	2	4	65	50	44	6
	3	5	75	50	63	13
	4	5	80	50	82	32
	5	5	80	60	101	41
	6	5	80	60	120	60
150	1	4	60	40	25	15
	2	4	65	50	44	6
	3	5	75	50	63	13
	4	5	80	50	82	32
	5	5	80	60	101	41
	6	5	88	60	120	60
160	1	4	65	40	25	15
	2	4	68	50	44	6
	3	5	80	50	63	13
	4	5	88	60	82	22
	5	5	88	60	101	41
	6	5	88	65	120	55
170	1	4	65	40	25	15
	2	4	68	50	44	6
	3	5	80	50	63	13
	4	5	88	60	82	22
	5	5	88	60	101	41
	6	5	104	65	120	55
180	1	4	65	40	25	15
	2	4	68	50	44	6
	3	5	80	50	63	13
	4	5	88	60	82	22
	5	5	88	70	101	31
	6	5	104	70	120	50
190	1	4	65	40	25	15
	2	4	68	50	44	6
	3	5	80	50	63	13
	4	5	88	60	82	22
	5	5	88	70	101	31
	6	5	104	70	120	50
200	1	4	68	40	25	15
	2	4	68	50	44	6
	3	5	80	50	63	13
	4	5	88	60	82	22
	5	5	88	70	101	31
	6	5	104	80	120	40
212	1	4	68	45	25	20
	2	4	68	50	44	6
	3	5	80	50	63	13
	4	5	88	60	82	22
	5	5	88	70	101	31
	6	5	104	80	120	40
224	1	4	68	45	25	20
	2	4	75	50	44	6
	3	5	80	50	63	13
	4	5	88	60	82	22
	5	5	96	70	101	31
	6	5	104	80	120	40
236	1	4	68	45	25	20
	2	4	75	50	44	6
	3	5	80	60	63	3
	4	5	88	65	82	17
	5	5	96	75	101	26
	6	5	104	80	120	40

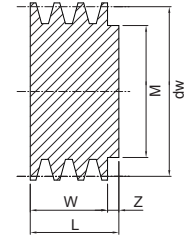

1

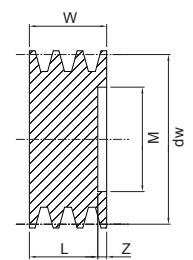

2

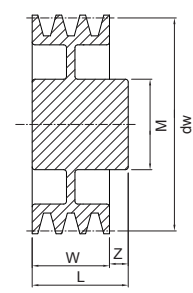

4

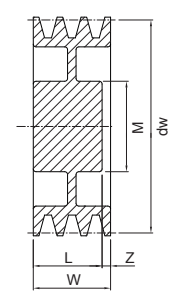

5

* Note: Le diamètre en fond de gorge est de 32 mm
 ** Note: Le diamètre en fond de gorge est de 43 mm

Dimensions des poulies à gorges trapézoïdales PT - moyeu plein

» PT SPB-B-5V



ø primitif [mm]	Nb de gorges	Type	M [mm]	L [mm]	W [mm]	z [mm]
250	1	8	70	45	25	20
	2	8	75	50	44	6
	3	9	88	60	63	3
	4	9	96	65	82	17
	5	4A	104	75	101	26
	6	4A	104	80	120	40
280	1	8	75	45	25	20
	2	8	75	50	44	6
	3	9	88	60	63	3
	4	9	96	65	82	17
	5	9	104	75	101	26
	6	9	104	80	120	40
300	1	8	75	50	25	25
	2	8	80	50	44	6
	3	9	88	60	63	3
	4	9	96	65	82	17
	5	9	104	75	101	26
	6	9	104	80	120	40
315	2	8	88	60	44	16
	3	9	88	60	63	3
	4	9	96	65	82	17
	5	9	104	75	101	26
	6	9	120	90	120	30
	355	1	8A	80	50	25
2		8	88	60	44	16
3		9	96	60	63	3
4		9	96	65	82	17
5		9	104	75	101	26
6		9	120	90	120	30
400	2	8A	88	60	44	16
	3	8A	96	65	63	2
	4	9A	104	75	82	7
	5	9A	112	85	101	16
	6	9A	120	100	120	20
	450	2	8A	88	60	44
3		8A	96	65	63	2
4		9A	104	75	82	7
5		9A	112	85	101	16
6		9A	120	100	120	20
500		2	8A	96	65	44
	3	8A	104	75	63	12
	4	8A	112	85	82	3
	5	9A	120	90	101	11
	6	9A	128	105	120	15
	560	2	8A	96	65	44
3		8A	104	75	63	12
4		8A	112	85	82	3
5		9A	120	90	101	11
6		9A	128	105	120	15

ø primitif [mm]	Nb de gorges	Type	M [mm]	L [mm]	W [mm]	z [mm]
630	2	8A	104	65	44	21
	3	8A	120	75	63	12
	4	8A	128	105	82	23
	5	8A	145	115	101	14
	6	9A	145	115	120	5
	710	2	8A	96	65	44
3		8A	112	75	63	12
4		8A	120	90	82	8
5		8A	128	105	101	4
6		9A	145	115	120	5
800		2	8A	104	70	44
	3	8A	120	90	63	27
	4	8A	128	105	82	23
	5	8A	145	115	101	14
	6	9A	145	115	120	5

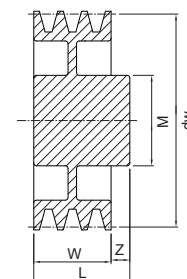

4
forme disque avec trous

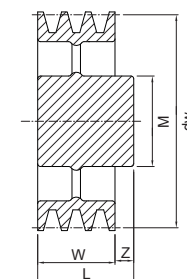

8 (3 bras)

8A (6 bras)

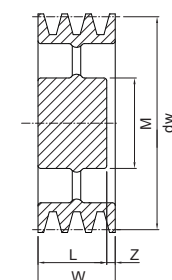

9
9A (3 bras)

Dimensions des poulies à gorges trapézoïdales PT - moyeu plein

PT C

ø primitif [mm]	Nb de gorges	Type	M [mm]	L [mm]	W [mm]	d [mm]	z [mm]
140	1	6	62	58	34	16	24
	2	7	70	58	59,5	16	2
	3	3	83	70	85	16	15
	4	3	83	74	110,5	16	37
	5	3	83	78	136	16	58
	6	3	83	78	161,5	20	84
150	1	6	70	59	34	16	25
	2	6	70	61	59,5	16	2
	3	3	93	70	85	16	15
	4	3	93	74	110,5	16	37
	5	3	93	78	136	16	58
	6	3	93	78	161,5	20	84
160	1	6	62	59	34	16	25
	2	6	70	61	59,5	16	2
	3	3	103	70	85	16	15
	4	3	103	74	110,5	20	37
	5	3	103	78	136	20	58
	6	3	103	78	161,5	20	84
170	1	6	70	60	34	16	26
	2	6	70	62	59,5	16	3
	3	7	78	74	85	20	11
	4	3	113	74	110,5	20	37
	5	3	113	78	136	20	58
	6	3	113	80	161,5	20	82
180	1	6	70	60	34	16	26
	2	6	70	60	59,5	16	1
	3	7	78	72	85	20	13
	4	7	82	74	110,5	20	37
	5	7	82	80	136	20	56
	6	7	87	72	161,5	20	90
190	1	6	70	60	34	16	26
	2	6	74	60	59,5	16	1
	3	7	78	72	85	20	13
	4	7	82	74	110,5	20	37
	5	7	84	80	136	20	56
	6	7	88	85	161,5	20	77
200	1	6	71	60	34	16	26
	2	6	73	72	59,5	20	13
	3	7	83	76	85	20	9
	4	7	90	88	110,5	20	23
	5	7	92	92	136	20	44
	6	7	96	98	161,5	20	64
224	1	6	71	63	34	20	29
	2	6	76	68	59,5	20	9
	3	7	83	76	85	20	9
	4	7	93	90	110,5	20	21
	5	7	93	92	136	25	44
	6	7	98	98	161,5	25	64
250	1	6	82	63	34	20	29
	2	6	82	71	59,5	20	12
	3	7	90	80	85	20	5
	4	7	95	90	110,5	20	21
	5	7	100	96	136	25	40
	6	7	102	102	161,5	25	60

» PT C

ø primitif [mm]	Nb de gorges	Type	M [mm]	L [mm]	W [mm]	d [mm]	z [mm]
280	1	6	82	64	34	20	30
	2	6	82	74	59,5	20	15
	3	7	90	80	85	20	5
	4	7	95	90	110,5	20	21
	5	7	100	96	136	25	40
	6	11	102	102	161,5	25	60
300	1	11	85	65	34	20	31
	2	11	90	75	59,5	20	16
	3	11	90	80	85	20	5
	4	11	105	90	110,5	20	21
	5	11	105	95	136	25	41
	6	11	105	107	161,5	25	55
315	1	11	85	65	34	20	31
	2	11	90	75	59,5	20	16
	3	11	90	80	85	20	5
	4	11	105	90	110,5	25	21
	5	11	105	95	136	25	41
	6	11	105	107	161,5	25	55
355	1	11	100	70	34	25	36
	2	11	105	80	59,5	25	21
	3	11	105	80	85	25	5
	4	11	115	90	110,5	25	21
	5	11	115	95	136	25	41
	6	11	115	110	161,5	25	52
400	1	11	100	70	34	25	36
	2	11	105	75	59,5	25	16
	3	11	105	80	85	25	5
	4	11	120	90	110,5	25	21
	5	11	120	95	136	25	41
	6	11	120	110	161,5	25	52
450	1	11	105	70	34	25	36
	2	11	110	75	59,5	25	16
	3	11	110	80	85	25	5
	4	11	120	95	110,5	32	16
	5	11	120	100	136	32	36
	6	11	120	110	161,5	32	52
500	1	11	110	75	34	25	41
	2	11	115	80	59,5	25	21
	3	11	115	85	85	25	-
	4	11	125	100	110,5	32	11
	5	11	125	110	136	32	26
	6	11	125	115	161,5	32	47
560	1	11	110	75	34	25	41
	2	11	115	80	59,5	25	21
	3	11	115	85	85	25	-
	4	11	125	100	110,5	32	11
	5	11	125	110	136	32	26
	6	11	125	115	161,5	32	47
630	1	11	115	75	34	25	41
	2	11	120	80	59,5	25	21
	3	11	120	95	85	25	10
	4	11	130	100	110,5	32	11
	5	11	130	110	136	32	26
	6	11	130	115	161,5	32	47

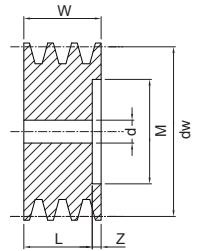

3

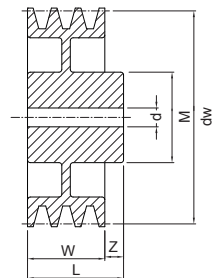

6

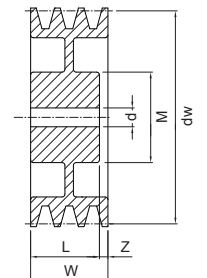

7

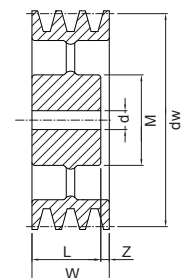

11

Dimensions des poulies à gorges trapézoïdales PBT - moyeu amovible SER-SIT®



“PBT” SPZ-Z-3V

dw [mm]	Nb de gorges	Type	Moyeu amovible SER-SIT®	d min-max [mm]	M [mm]	L [mm]	Z [mm]	U [mm]	W [mm]
63	1	1	1108	11-28	62	22	6	-	16
	2	10	1108	11-28	-	22	6	38	28
	3	10	1108	11-28	-	22	18	38	40
67	1	1	1108	11-28	62	22	6	-	16
	2	10	1108	11-28	-	22	6	38	28
	3	10	1108	11-28	-	22	18	38	40
71	1	1	1108	11-28	62	22	6	-	16
	2	10	1108	11-28	-	22	6	42	28
	3	10	1108	11-28	-	22	18	42	40
75	1	1	1108	11-28	62	22	6	-	16
	2	10	1210	11-32	-	25	3	48	28
	3	10	1210	11-32	-	25	15	48	40
	4	10	1210	11-32	-	25	27	48	52
80	1	1	1210	11-32	75	25	9	-	16
	2	10	1210	11-32	-	25	3	52	28
	3	10	1210	11-32	-	25	15	52	40
	4	10	1210	11-32	-	25	27	52	52
85	1	1	1210	11-32	86	25	9	-	16
	2	10	1610	12-42	-	25	3	57	28
	3	10	1610	12-42	-	25	15	57	40
	4	10	1610	12-42	-	25	27	57	52
	5	10	1610	12-42	-	25	39	57	64
90	1	1	1210	11-32	86	25	9	-	16
	2	10	1610	12-42	-	25	3	62	28
	3	10	1610	12-42	-	25	15	62	40
	4	10	1610	12-42	-	25	27	62	52
	5	10	1610	12-42	-	25	39	62	64
	6	10	1610	12-42	-	26	50	62	76
95	1	1	1210	11-32	86	25	9	-	16
	2	10	1610	12-42	-	25	3	67	28
	3	10	1610	12-42	-	25	15	67	40
	4	10	1610	12-42	-	25	27	67	52
	5	10	1610	12-42	-	25	39	67	64
	6	10	1610	12-42	-	26	50	67	76
100	1	1	1210	11-32	86	25	9	-	16
	2	10	1610	12-42	-	25	3	71	28
	3	10	1610	12-42	10	25	15	71	40
	4	10	1610	12-42	-	25	27	71	52
	5	10	2012	14-50	-	32	32	71	64
	6	10	2012	14-50	-	32	44	71	76
106	1	1	1610	12-42	92	25	9	-	16
	2	10	1610	12-42	-	25	3	76	28
	3	10	1610	12-42	-	25	15	76	40
	4	10	1610	12-42	-	25	27	76	52
	5	10	2012	14-50	-	32	32	76	64
	6	10	2012	14-50	-	31	45	76	76
112	1	1	1610	12-42	92	25	9	-	16
	2	10	1610	12-42	-	25	3	84	28
	3	10	2012	14-50	-	32	8	84	40
	4	10	2012	14-50	-	32	20	84	52
	5	10	2012	14-50	-	32	32	84	64
	6	10	2012	14-50	-	31	45	84	76

Désignation

PBT 100 SPZ 2

Poulie trapézoïdale - moyeu amovible

Diamètre primitif [mm]

Section

Nombre de gorges

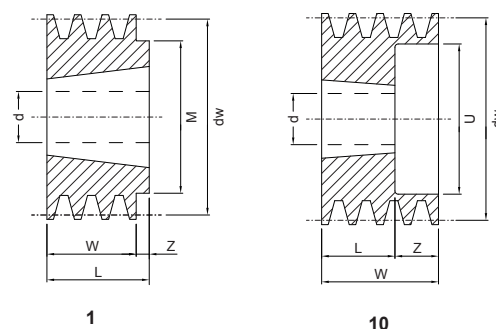

Dimensions des poulies à gorges trapézoïdales PBT - moyeu amovible SER-SIT®



» "PBT" SPZ-Z-3V

dw [mm]	Nb de gorges	Type	Moyeu amovible SER-SIT®	d min-max [mm]	M [mm]	L [mm]	Z [mm]	U [mm]	W [mm]
118	1	1	1610	12-42	92	25	9	-	16
	2	10	1610	12-42	-	25	3	90	28
	3	2	2012	14-50	-	32	8	90	40
	4	2	2012	14-50	-	32	20	90	52
	5	10	2012	14-50	-	32	32	90	64
	6	2	2012	14-50	-	31	45	90	76
125	1	1	1610	12-42	92	25	9	-	16
	2	10	1610	12-42	-	25	3	98	28
	3	2	2012	14-50	-	32	8	98	40
	4	2	2012	14-50	-	32	20	98	52
	5	2	2012	14-50	-	32	32	98	64
	6	10	2517	18-65	-	46	30	98	76
132	1	1	1610	12-42	92	25	9	-	16
	2	10	1610	12-42	-	25	3	103	28
	3	2	2012	14-50	-	32	8	103	40
	4	2	2012	14-50	-	32	20	103	52
	5	10	2517	18-65	-	45	19	103	64
	6	2	2517	18-65	-	46	30	103	76
140	1	4	1610	12-42	92	25	9	-	16
	2	10	1610	12-42	-	25	3	112	28
	3	2	2012	14-50	-	32	8	112	40
	4	2	2012	14-50	-	32	20	112	52
	5	2	2517	18-65	-	45	19	112	64
	6	2	2517	18-65	-	46	30	112	76
150	-	-	-	-	-	-	-	-	-
	2	1	2012	14-50	112	32	4	-	28
	3	2	2012	14-50	-	32	8	122	40
	4	2	2517	18-65	-	45	7	122	52
	5	2	2517	18-65	-	45	19	122	64
	6	2	2517	18-65	-	46	30	122	76
160	1	4	1610	12-42	92	25	9	-	16
	2	4	2012	14-50	112	32	4	-	28
	3	2	2012	14-50	-	32	8	131	40
	4	2	2517	18-65	-	45	7	131	52
	5	2	2517	18-65	-	45	19	131	64
	6	5	2517	18-55	120	46	30	133	76
180	1	4	1610	12-42	92	25	9	152	16
	2	4	2012	14-50	106	32	4	152	28
	3	5	2012	14-50	106	32	8	152	40
	4	2	2517	18-65	-	45	7	152	52
	5	2	2517	18-65	-	45	19	152	64
	6	5	2517	18-55	120	46	30	152	76
190	2	4	2012	14-50	106	32	10	162	28
200	1	4	2012	14-50	112	32	16	171	16
	2	4	2012	14-50	112	32	4	171	28
	3	6	2012	14-50	112	32	4	171	40
	4	6	2517	18-65	125	45	3,5	171	52
	-	-	-	-	-	-	-	-	-
	6	6	2517	18-65	120	46	15	171	76
224	1	12	2012	14-50	110	32	8	195	16
	2	7	2012	14-50	112	32	4	195	28
	3	6	2012	14-50	112	32	4	195	40
	-	-	-	-	-	-	-	-	-
	5	6	2517	18-65	124	45	9,5	195	64
	6	5	2517	18-65	120	46	30	195	76

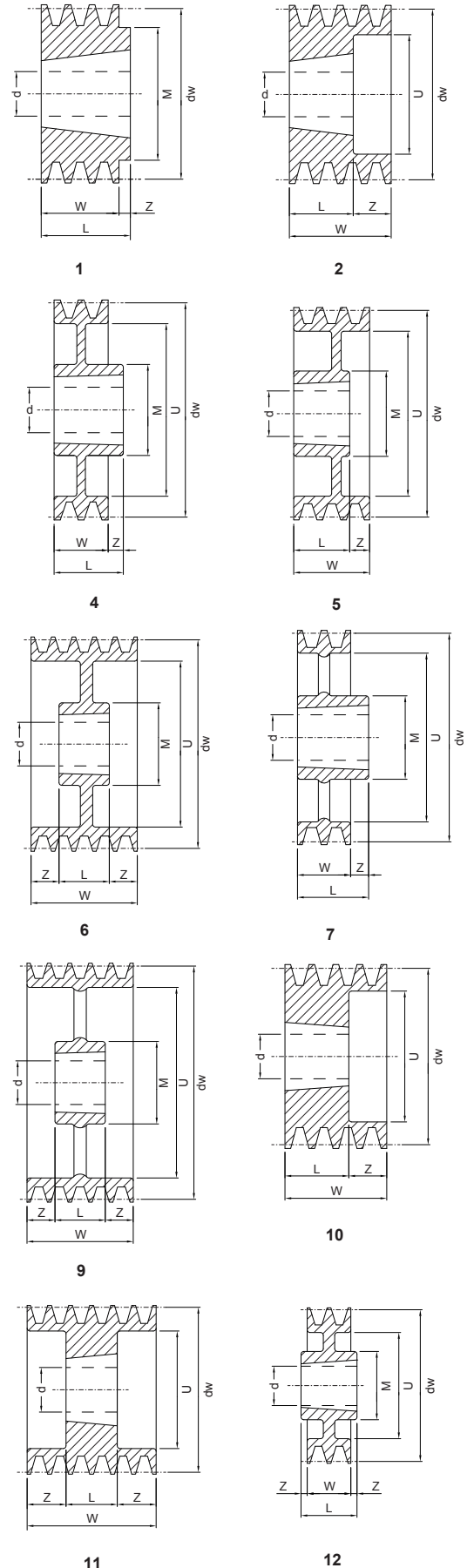

POULIES À GORGES TRAPÉZOÏDALES- PBT

Dimensions des poulies à gorges trapézoïdales PBT - moyeu amovible SER-SIT®



» "PBT" SPZ-Z-3V

dw [mm]	Nb de gorges	Type	Moyeu amovible SER-SIT®	d min-max [mm]	M [mm]	L [mm]	Z [mm]	U [mm]	W [mm]	
250	1	3	2012	14-50	110	32	8	223	16	
	2	3	2012	14-50	110	32	2	223	28	
	3	9	2012	14-50	112	32	4	223	40	
	-	-	-	-	-	-	-	-	-	-
	5	6	2517	18-65	124	45	9,5	223	64	
	6	6	2517	18-65	120	46	15	223	76	
280	1	3	2012	14-50	110	32	8	252	16	
	2	3	2012	14-50	112	32	2	252	28	
	3	3	2517	18-65	124	45	2,5	252	40	
	4	9	2517	18-65	124	45	3,5	252	52	
	5	9	2517	18-65	124	45	9,5	221	64	
	6	8	2517	18-55	120	46	30	252	76	
315	1	3	2012	14-50	110	32	8	288	16	
	2	3	2012	14-50	110	32	2	288	28	
	3	3	2517	18-65	120	45	2,5	288	40	
	4	9	2517	18-65	120	45	3,5	288	52	
	5	9	2517	18-65	120	45	9,5	288	64	
	6	6	2517	18-65	125	45	15,5	288	76	
355	1	3	2012	14-50	110	32	8	326	16	
	2	3	2012	14-50	112	32	2	326	28	
	3	3	2517	18-65	125	45	2,5	326	40	
	4	9	2517	18-65	124	45	3,5	326	52	
	5	9	2517	18-65	124	45	9,5	326	64	
	6	8	2517	18-65	120	46	30	326	76	
400	1	3	2012	14-50	110	32	8	372	16	
	2	3	2517	18-65	120	45	8,5	372	28	
	3	3	2517	18-65	120	45	2,5	372	40	
	4	9	2517	18-65	120	45	3,5	372	52	
	5	9	3020	22-75	146	51	6,5	372	64	
	6	9	3030	25-75	150	76	-	372	76	
450	1	3	2517	18-65	124	45	14,5	421	16	
	2	3	2517	18-65	124	45	8,5	421	28	
	3	3	2517	18-65	124	45	2,5	421	40	
	4	9	3020	22-75	146	45	0,5	421	52	
	5	9	3020	22-75	146	51	6,5	421	64	
	6	8	3020	22-75	140	76	-	421	76	
500	1	7	2517	18-65	120	46	30	473	16	
	2	3	2517	18-65	125	45	8,5	473	28	
	3	3	2517	18-65	120	45	2,5	473	40	
	4	9	3020	22-75	146	51	1	473	52	
	5	3	3030	25-75	146	76	6	473	64	
	6	9	3020	22-75	140	76	-	473	76	
630	1	7	2517	18-65	120	46	30	603	16	
	2	7	2517	18-65	120	46	18	603	28	
	3	3	2517	18-65	120	46	3	603	40	
	4	9	3020	22-75	146	51	0,5	603	52	
	5	9	3020	22-75	146	51	6,5	603	64	

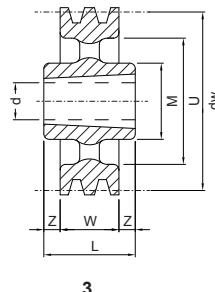

3

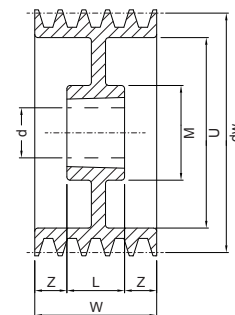

6

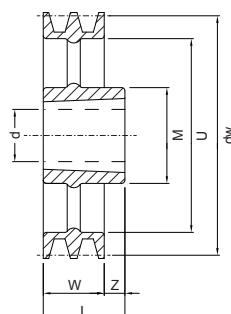

7

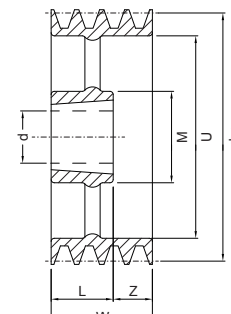

8

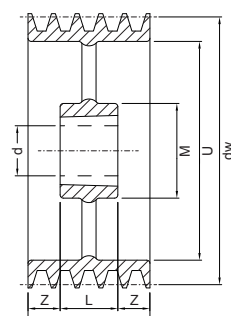

9

Dimensions des poulies à gorges trapézoïdales PBT - moyeu amovible SER-SIT®



“PBT” SPA-A

dw [mm]	Nb de gorges	Type	Moyeu amovible SER-SIT®	d min-max [mm]	M [mm]	L [mm]	Z [mm]	U [mm]	W [mm]
67	2	10	1108	11-28	-	22	13	37	35
71	-	-	-	-	60	22	-	-	-
	2	10	1108	11-28	-	22	13	40	35
75	3	10	1108	11-28	-	22	28	40	50
	-	-	-	-	60	22	-	-	-
80	2	10	1108	11-28	-	22	13	44	35
	3	10	1108	11-28	-	22	28	44	50
85	-	-	-	-	84	25	-	-	-
	2	10	1210	11-32	-	25	10	50	35
90	3	10	1210	11-32	-	25	25	50	50
	-	-	-	-	88	25	-	-	-
95	2	10	1210	11-32	-	25	10	55	35
	3	10	1210	11-32	-	25	25	55	50
99	-	-	-	-	90	25	-	-	-
	2	10	1610	12-42	-	25	10	60	35
105	3	10	1610	12-42	-	25	25	56	50
	4	10	1615	12-42	-	38	27	60	65
110	-	-	-	-	90	25	-	-	-
	2	10	1610	12-42	-	25	10	62	35
115	3	10	1610	12-42	-	25	25	62	50
	4	10	1615	12-42	-	38	27	62	65
120	-	-	-	-	92	25	-	-	-
	2	10	1610	12-42	-	25	10	66	35
125	3	2	1610	12-42	-	25	25	66	50
	4	2	1615	12-42	-	38	27	66	65
130	5	2	1615	12-42	-	38	42	66	80
	-	-	-	-	85	25	-	-	-
135	2	10	1610	12-42	-	25	10	72	35
	3	2	1610	12-42	-	25	25	72	50
140	4	10	2012	14-50	-	32	33	72	65
	5	10	2012	14-50	-	32	48	72	80
145	-	-	-	-	90	25	-	-	-
	2	10	1610	12-42	-	25	10	77	35
150	3	10	2012	14-50	-	32	18	77	50
	4	10	2012	14-50	-	32	33	77	65
155	5	10	2012	14-50	-	32	48	77	80
	-	-	-	-	96,4	25	-	-	-
160	2	10	1610	12-42	-	25	10	85	35
	3	2	2012	14-50	-	32	18	85	50
165	4	2	2012	14-50	-	32	33	85	65
	5	2	2012	14-50	-	32	48	85	80
170	-	-	-	-	92	25	-	-	-
	2	10	1610	12-42	-	25	10	92	35
175	3	2	2012	14-50	-	32	18	92	50
	4	2	2012	14-50	-	32	33	92	65
180	5	11	2012	14-50	-	32	24	92	80
	-	-	-	-	92	25	-	-	-
185	2	10	2012	14-50	-	32	3	97	35
	3	2	2012	14-50	-	32	18	97	50
190	4	2	2517	18-65	-	45	20	97	65
	5	11	2517	18-65	-	45	17,5	102	80
195	-	-	-	-	92	25	-	-	-
	2	10	2012	14-50	-	32	3	106	35
200	3	10	2517	18-65	-	45	5	106	50
	4	2	2517	18-65	-	45	20	106	65
205	5	11	2517	18-65	-	45	17,5	106	80

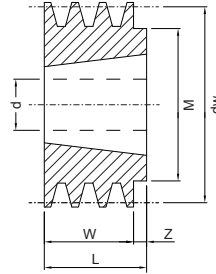

1

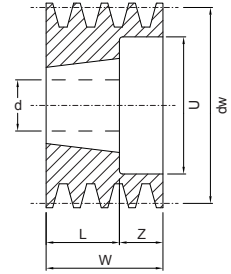

2

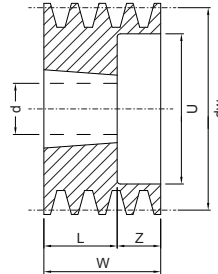

10

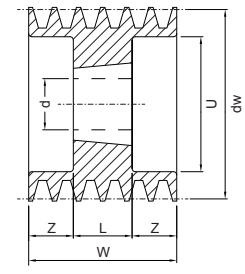

11

Dimensions des poulies à gorges trapézoïdales PBT - moyeu amovible SER-SIT®



» "PBT" SPA-A

dw [mm]	Nb de gorges	Type	Moyeu amovible SER-SIT®	d min-max [mm]	M [mm]	L [mm]	Z [mm]	U [mm]	W [mm]
150	1	4	1610	12-42	92	25	5	-	20
	2	10	2012	14-50	-	32	3	116	35
	3	10	2517	18-65	-	45	5	116	50
	4	2	2517	18-65	-	45	20	116	65
	5	11	2517	18-65	-	45	17,5	116	80
160	-	-	-	-	-	-	-	-	-
	2	10	2012	14-50	-	32	3	126	35
	3	10	2517	18-65	-	45	5	126	50
	4	2	2517	18-65	-	45	20	126	65
	5	11	2517	18-65	-	45	17,5	126	80
170	1	4	1610	12-42	92	25	5	-	20
	2	10	2012	14-50	-	32	3	135	35
	3	10	2517	18-65	-	45	5	135	50
	4	2	2517	18-65	-	45	20	135	65
	5	11	2517	18-65	-	45	17,5	135	80
180	1	4	1610	12-42	92	25	5	146	20
	2	6	2012	14-50	108	32	1,5	146	35
	3	10	2517	18-65	-	45	5	146	50
	4	2	2517	18-65	-	45	20	146	65
	5	11	3020	22-75	-	51	14,5	146	80
190	-	-	-	-	-	-	-	-	-
	2	6	2012	14-50	108	32	1,5	156	35
	3	10	2517	18-65	-	45	5	165	50
	4	2	2517	18-65	-	45	20	165	65
	5	2	3020	22-75	-	51	29	165	80
200	1	4	2012	14-50	108	32	12	165	20
	2	12	2517	18-65	123	45	5	165	35
	3	6	2517	18-65	123	45	2,5	177	50
	4	2	3020	22-75	-	51	14	165	65
	5	11	3020	22-75	-	51	14,5	165	80
212	1	4	2012	14-50	110	32	12	178	20
	2	4	2517	18-65	120	45	10	178	35
	3	6	2517	18-65	123	45	2,5	189	50
	4	2	3020	22-75	-	51	14	178	65
224	1	7	2012	14-50	112	32	12	189	20
	2	4	2517	18-65	124	45	10	189	35
	3	6	2517	18-65	124	45	2,5	189	50
	4	2	3020	22-75	-	51	14	189	65
	5	2	3020	22-75	-	51	29	189	80
236	1	7	2012	14-50	110	32	12	203	20
	2	7	2517	18-65	124	45	10	203	35
	3	9	2517	18-65	124	45	2,5	203	50
	4	6	3020	22-75	146	51	7	203	65
	5	6	3020	22-75	155	51	14,5	203	80
250	1	3	2012	14-50	112	32	6	215	20
	2	3	2517	18-65	124	45	5	215	35
	3	9	2517	18-65	124	45	2,5	215	50
	4	6	3020	22-75	159	51	7	215	65
	5	6	3020	22-75	159	51	14,5	215	80
280	1	7	2012	14-50	110	32	10	246	20
	2	7	2517	18-65	120	45	10	246	35
	3	9	2517	18-65	124	45	2,5	246	50
	4	9	3020	22-75	146	51	7	246	65
	5	12	3535	25-90	175	89	4,5	246	80
300	1	7	2012	14-50	112	32	12	266	20
	2	7	2517	18-65	124	45	10	266	35
	3	7	3020	22-75	146	51	1	266	50
	4	9	3020	22-75	146	51	7	266	65
	5	4	3535	25-90	175	89	9	266	80

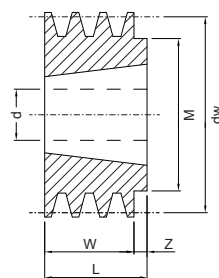

1

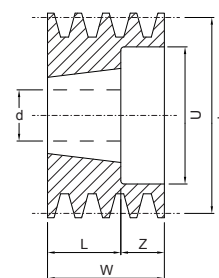

2

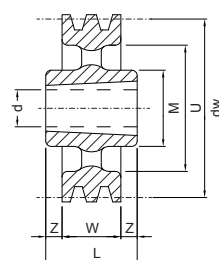

3

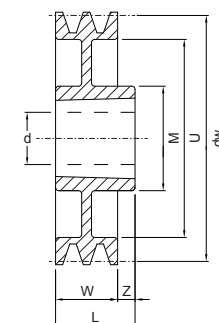

4

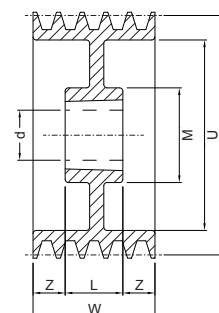

6

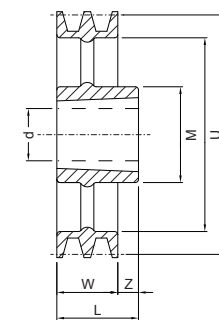

7

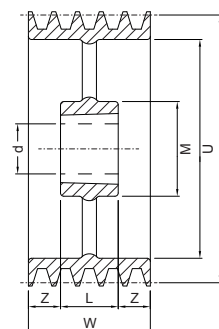

9

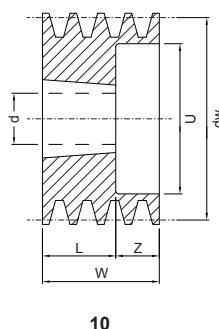

10

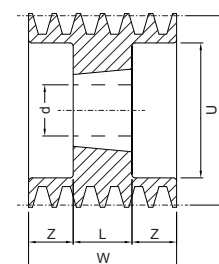

11

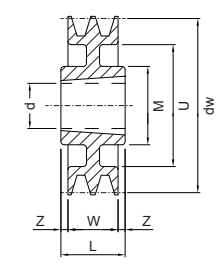

12

Dimensions des poulies à gorges trapézoïdales PBT - moyeu amovible SER-SIT®



» "PBT" SPA-A

dw [mm]	Nb de gorges	Type	Moyeu amovible SER-SIT®	d min-max [mm]	M [mm]	L [mm]	Z [mm]	U [mm]	W [mm]
315	1	7	2012	14-50	110	32	10	282	20
	2	7	2517	18-65	120	45	10	282	35
	3	3	3020	22-75	146	51	0,5	282	50
	4	9	3020	22-75	146	51	7	282	65
	-	-	-	-	-	-	-	-	-
355	1	7	2012	14-50	110	32	10	322	20
	2	7	2517	18-65	120	45	10	322	35
	3	3	3020	22-75	146	51	0,5	322	50
	4	9	3020	22-75	146	51	7	322	65
	5	3	3535	22-75	175	89	4,5	322	80
400	1	7	2012	14-50	110	32	10	366	20
	2	7	2517	18-65	120	45	10	366	35
	3	7	3020	22-75	159	51	1	366	50
	4	9	3020	22-75	146	51	7	366	65
	5	3	3535	25-90	180	89	9	366	80
450	1	7	2012	14-50	110	32	12	416	20
	2	7	2517	18-65	120	45	10	416	35
	3	7	3020	22-75	159	51	1	416	50
	4	9	3020	22-75	146	51	7	416	65
	5	3	3535	22-75	175	89	4,5	416	80
500	1	7	2517	18-65	120	45	25	467	20
	2	7	2517	18-65	120	45	10	467	35
	3	7	3020	22-75	159	51	1	465	50
	4	9	3020	22-75	146	51	7	467	65
	5	3	3535	25-90	180	89	9	467	80
560	1	7	2517	18-65	124	45	25	526	20
	2	7	3020	22-75	146	51	16	526	35
	3	7	3020	22-75	146	51	1	526	50
	4	3	3535	25-90	175	89	12	526	65
	5	3	3535	25-90	178	89	9	526	80
630	1	7	2517	18-65	124	45	25	596	20
	2	3	3020	22-75	159	51	8	596	35
	3	7	3020	22-75	160	51	1	596	50
	4	3	3535	25-90	175	89	12	596	65
	5	3	3535	25-90	178	89	9	596	80
800	2	3	3535	25-90	178	89	27	765	35
	3	3	3535	25-90	178	89	19,5	765	50
	4	3	3535	25-90	178	89	12	765	65
	5	3	4040	40-100	216	102	11	765	80
900	3	3	3535	25-90	178	89	19,5	865	50
	4	3	3535	25-90	178	89	12	865	65
	5	3	4040	40-100	216	102	11	865	80
1000	3	3	3535	25-90	178	89	19,5	965	50
	4	3	4040	40-100	216	102	18,5	965	65
	5	3	4545	55-110	242	114	17	965	80

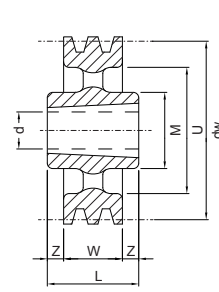

3

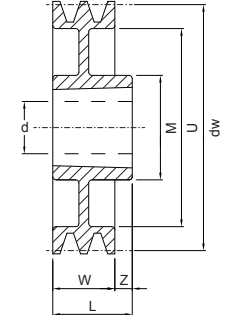

4

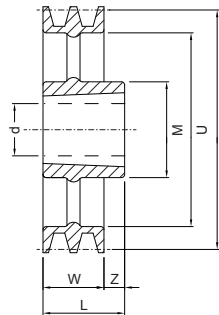

7

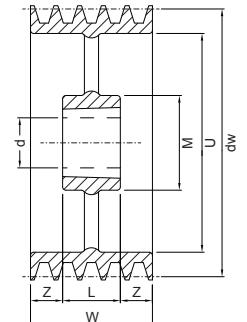

9

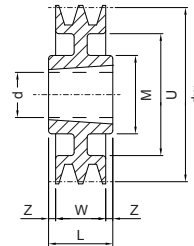

12

Dimensions des poulies à gorges trapézoïdales PBT - moyeu amovible SER-SIT®



“PBT” SPB-B-5V

dw [mm]	Nb de gorges	Type	Moyeu amovible SER-SIT®	d min-max [mm]	M [mm]	L [mm]	Z [mm]	U [mm]	W [mm]
90	1	1	1210	14-50	-	25	-	-	25
	2	10	1210	14-50	-	25	19	52	44
	3	10	1210	14-50	-	25	38	50	63
100	1	1	1610	12-42	-	25	-	-	25
	2	10	1610	12-42	-	25	19	57	44
	3	10	1610	12-42	-	25	38	57	63
112	1	1	1610	12-42	-	25	-	-	25
	2	2	1610	12-42	-	25	19	69	44
	3	10	1610	12-42	-	25	38	69	63
	4	10	1610	12-42	-	25	57	72	82
118	1	1	1610	12-42	-	25	-	-	25
	2	2	1610	12-42	-	25	19	69	44
	3	10	1610	12-42	-	25	38	76	63
125	1	1	1610	12-42	-	25	-	-	25
	2	2	2012	14-50	-	32	12	86	44
	3	2	2012	14-50	-	32	31	86	63
	4	11	2012	14-50	-	32	25	86	82
132	1	1	1610	12-42	-	25	-	-	25
	2	2	2012	14-50	-	32	12	89	44
	3	2	2012	14-50	-	32	31	89	63
	4	11	2012	14-50	-	32	25	89	82
	5	10	2517	18-65	-	45	56	94	101
140	1	1	1610	12-42	-	25	-	-	25
	2	2	2012	14-50	-	32	12	97	44
	3	2	2012	14-50	-	32	31	97	63
	4	11	2517	18-65	-	45	18,5	102	82
	5	11	2517	18-65	-	45	28	102	101
	6	11	2517	18-65	-	45	37,5	102	120
150	-	-	-	-	-	-	-	-	-
	2	2	2012	14-50	-	32	12	107	44
	3	2	2517	18-65	-	45	18	107	63
	4	11	2517	18-65	-	45	18,5	107	82
	5	11	2517	18-65	-	45	28	107	101
	6	11	2517	18-65	-	45	37,5	107	120
160	-	-	-	-	-	-	-	-	-
	2	2	2012	14-50	-	32	12	120	44
	3	2	2517	18-65	-	45	18	120	63
	4	11	2517	18-65	-	45	18,5	117	82
	5	11	2517	18-65	-	45	28	117	101
	6	11	3020	22-75	-	51	34,5	123	120
170	1	4	1610	12-42	-	25	-	-	25
	2	2	2012	14-50	-	32	12	130	44
	3	2	2517	18-65	-	45	18	130	63
	4	11	2517	18-65	-	45	18,5	127	82
	5	11	3020	22-75	-	51	25	127	101
	6	11	3020	22-75	-	51	34,5	127	120
	8	11	3030*	25-75	-	51	53,5	130	158
	180	1	6	1610	12-42	90	25	-	132
2		1	2517	18-65	120	45	1	-	44
3		2	2517	18-65	-	45	18	137	63
4		11	2517	18-65	-	45	18,5	137	82
5		11	3020	22-75	-	51	25	142	101
6		11	3020	22-75	-	51	34,5	137	120
8		11	3030	25-75	-	76	41	137	158
190		1	12	2012	14-50	104	32	3,5	147
	2	1	2517	18-65	120	45	1	-	44
	3	2	2517	18-65	-	45	18	147	63
	4	11	2517	18-65	-	45	18,5	147	82
	5	11	3020	22-75	-	51	25	147	101
	6	11	3020	22-75	-	51	34,5	147	120
	8	11	3030	25-75	-	76	41	147	158

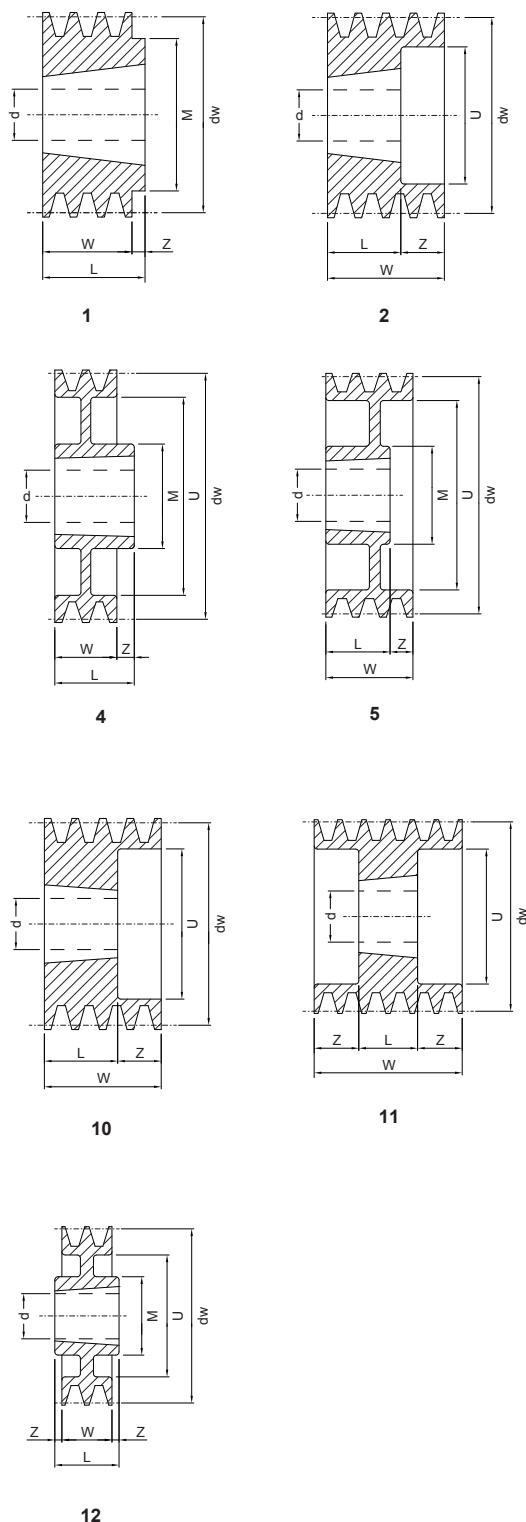

* = PBT170SPB8 - moyeu amovible type 3020 jusqu'à épuisement des stocks.

Dimensions des poulies à gorges trapézoïdales PBT - moyeu amovible SER-SIT®



» "PBT" SPB-B-5V

dw [mm]	Nb de gorges	Type	Moyeu amovible SER-SIT®	d min-max [mm]	M [mm]	L [mm]	Z [mm]	U [mm]	W [mm]	
200	1	12	2012	14-50	104	32	3,5	157	25	
	2	4	2517	18-65	117	45	1	-	44	
	3	2	2517	18-65	-	45	18	157	63	
	4	11	3020	22-75	-	51	15,5	157	82	
	5	11	3020	22-75	-	51	25	157	101	
	6	11	3020	22-75	-	51	34,5	157	120	
	8	11	3535	25-90	-	89	34,5	160	158	
212	1	3	2012	14-50	104	32	3,5	169	25	
	2	4	2517	18-65	125	45	1	169	44	
	3	5	2517	18-65	125	45	18	169	63	
	4	11	3020	22-75	-	51	15,5	169	82	
	5	11	3020	22-75	-	51	25	169	101	
	6	11	3535	25-90	-	89	15,5	169	120	
	8	11	3535	25-90	-	89	34,5	173	158	
224	1	12	2012	14-50	104	32	3,5	181	25	
	2	4	2517	18-65	117	45	1	181	44	
	3	5	2517	18-65	117	45	18	181	63	
	4	11	3020	22-75	-	51	15,5	181	82	
	5	11	3020	22-75	-	51	25	181	101	
	6	11	3535	25-90	-	89	15,5	181	120	
	8	11	3535	25-90	-	89	34,5	185	158	
236	2	4	2517	18-65	117	45	1	193	44	
	3	5	2517	18-65	117	45	18	193	63	
	4	11	3020	22-75	-	51	15,5	193	82	
	5	11	3535	25-90	-	89	6	196	101	
	6	11	3535	25-90	-	89	15,5	193	120	
250	-	-	-	-	-	-	-	-	-	
	-	-	-	-	-	-	-	-	-	
	3	5	3020	22-75	144	51	12	207	63	
	4	6	3020	22-75	144	51	15,5	207	82	
	5	11	3535	25-90	-	89	6	207	101	
280	1	11	3535	25-90	-	89	15,5	207	120	
	8	11	3535	25-90	-	89	34,5	207	158	
	1	3	2012	14-50	104	32	3,5	237	25	
	2	7	2517	18-65	125	45	1	237	44	
	3	9	3020	22-75	144	51	6	237	63	
280	4	6	3020	22-75	144	51	15,5	237	82	
	5	6	3535	25-90	175	89	6	237	101	
	6	6	3535	25-90	175	89	15,5	237	120	
	8	6	3535	25-90	175	89	34,5	237	158	
	300	1	3	2012	14-50	104	32	3,5	285	25
		-	-	-	-	-	-	-	-	-
3		9	3020	22-75	144	51	6	257	63	
4		4	3535	25-90	175	89	7	257	82	
5		6	3535	25-90	175	89	6	257	101	
6		6	3535	25-90	175	89	15,5	257	120	
300	8	6	3535	25-90	178	89	34,5	260	158	
	1	3	2012	14-50	104	32	3,5	272	25	
	2	7	2517	18-65	125	45	1	272	44	
	3	9	3020	22-75	144	51	6	272	63	
	4	3	3535	25-90	175	89	3,5	272	82	
	5	6	3535	25-90	175	89	6	272	101	
300	6	6	3535	25-90	175	89	15,5	272	120	
	8	6	3535	25-90	175	89	34,5	272	158	
	2	7	2517	18-65	125	45	1	292	44	
	3	9	3020	22-75	144	51	6	292	63	
	4	3	3535	25-90	175	89	3,5	292	82	
	5	6	3535	25-90	175	89	6	292	101	
335	-	-	-	-	-	-	-	-	-	
	-	-	-	-	-	-	-	-	-	
	-	-	-	-	-	-	-	-	-	
	-	-	-	-	-	-	-	-	-	
	-	-	-	-	-	-	-	-	-	

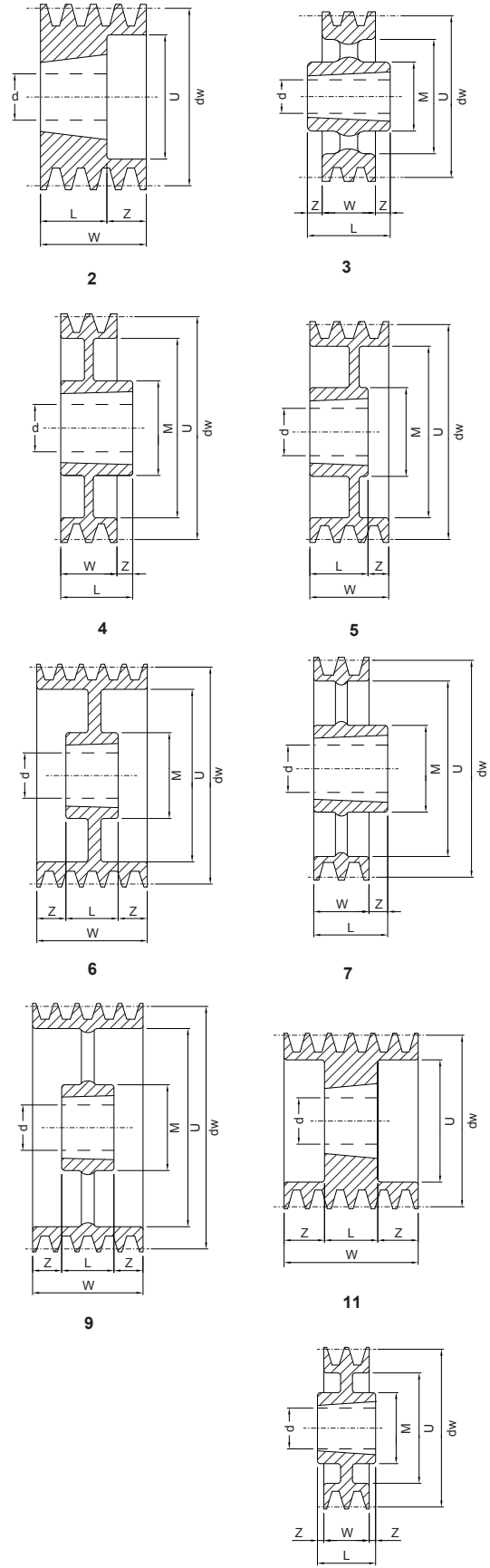

POULIES À GORGES TRAPÉZOÏDALES- PBT

Dimensions des poulies à gorges trapézoïdales PBT - moyeu amovible SER-SIT®



» "PBT" SPB-B-5V

dw [mm]	Nb de gorges	Type	Moyeu amovible SER-SIT®	d min-max [mm]	M [mm]	L [mm]	Z [mm]	U [mm]	W [mm]
355	2	3	3020	22-75	146	51	3,5	315	44
	3	9	3020	22-75	146	51	6	315	63
	4	3	3535	25-90	175	89	3,5	312	82
	-	-	-	-	-	-	-	-	-
	6	6	3535	25-90	175	89	15,5	312	120
-	-	-	-	-	-	-	-	-	
400	2	3	3020	22-75	146	51	3,5	360	44
	3	3	3535	25-90	175	89	13	357	63
	4	3	3535	25-90	175	89	3,5	357	82
	5	9	3535	25-90	175	89	6	357	101
	6	9	3535	25-90	175	89	15,5	357	120
-	-	-	-	-	-	-	-	-	
450	2	3	3020	22-75	150	51	3,5	407	44
	3	7	3535	25-90	178	89	26	410	63
	4	7	3535	25-90	178	89	7	410	82
	5	8	3535	25-90	178	89	12	410	101
	6	8	4040	40-100	215	102	18	410	120
	8	9	4040	40-100	215	102	28	410	158
500	2	3	3020	22-75	146	51	3,5	460	44
	3	7	3535	25-90	178	89	26	460	63
	4	7	3535	25-90	178	89	7	460	82
	5	8	3535	25-90	178	89	12	460	101
	6	8	4040	40-100	215	102	18	460	120
8	9	4040	40-100	215	102	28	460	158	
560	2	3	3030	25-75	150	76	16	520	44
	3	7	3535	25-90	178	89	26	520	63
	4	7	3535	25-90	178	89	7	520	82
	5	7	4040	40-100	210	102	1	520	101
	6	8	4040	40-100	215	102	18	520	120
	8	9	4545	55-110	242	114	22	520	158
630	2	3	3030	25-75	150	76	16	590	44
	3	7	3535	25-90	178	89	26	590	63
	4	7	3535	25-90	178	89	7	590	82
	5	7	4040	40-100	215	102	1	590	101
	6	8	4040	40-100	215	102	18	590	120
8	9	4545	55-110	242	114	22	590	158	
710	2	7	3535	25-90	185	89	45	664	44
	3	3	3535	25-90	175	89	13	664	63
	4	3	3535	25-90	185	89	3,5	664	82
	5	7	4040	40-100	215	101	1	664	101
	6	9	4545	55-110	240	114	3	664	120
8	9	4545	55-110	240	114	22	664	158	
800	2	3	3535	25-90	175	89	22,5	754	44
	3	3	3535	25-90	175	89	13	754	63
	4	3	4040	40-100	215	102	10	754	82
	5	7	4040	40-100	215	101	1	754	101
	6	9	4545	55-110	240	114	3	754	120
8	9	4545	55-110	240	114	22	754	158	
900	3	3	3535	25-90	185	89	13	854	63
	4	3	4040	40-100	216	102	10	854	82
	5	7	4040	40-100	210	102	1	854	101
	6	9	4545	55-110	240	114	3	854	120
8	9	4545	55-110	240	114	22	854	158	
1000	3	3	4040	40-100	216	102	6	954	63
	4	3	4040	40-100	216	102	4	954	82
	5	3	4545	55-110	240	114	6,5	954	101
	6	9	4545	55-110	240	114	3	954	120
	8	9	5050	50-125	265	127	15,5	954	158
1250	3	3	4040	50-125	210	102	19,5	1204	63
	4	3	4545	55-110	242	114	16	1204	82
	5	3	4545	55-110	242	114	6,5	1204	101
	6	9	4545	55-110	242	114	3	1204	120
8	9	5050	50-125	280	127	15,5	1204	158	

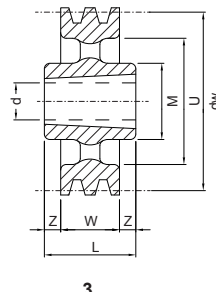

3

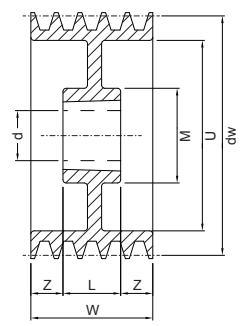

6

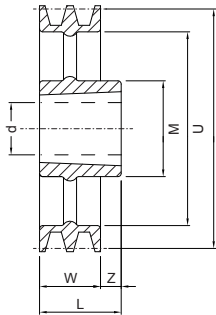

7

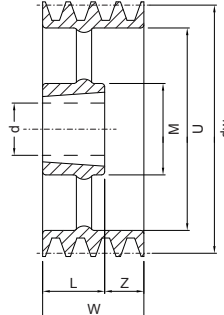

8

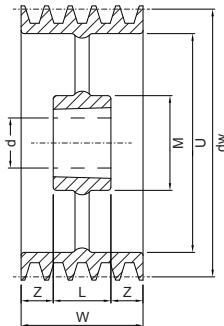

9

Dimensions des poulies à gorges trapézoïdales PBT - moyeu amovible SER-SIT®



“PBT” SPC-C

dw [mm]	Nb de gorges	Type	Moyeu amovible SER-SIT®	d min-max [mm]	M [mm]	L [mm]	Z [mm]	U [mm]	W [mm]
212	3	11	3020	22-75	-	51	17	156	85
	4	11	3020	22-75	-	51	29,5	156	110,5
	5	11	3535	25-90	-	89	23,5	156	136
	6	11	3535	25-90	-	89	36,25	156	161,5
	8	11	3535	25-90	-	89	61,75	156	212,5
224	3	11	3020	22-75	-	51	17	173	85
	4	11	3535	49-90	-	89	11	168	110,5
	5	11	3535	25-90	-	89	23,5	173	136
	6	11	3535	25-90	-	89	36,25	173	161,5
	8	11	3535	25-90	-	89	62	168	212,5
236	3	11	3020	22-75	-	51	17	180	85
	4	11	3535	25-90	-	89	10,75	180	110,5
	5	11	3535	25-90	-	89	23,5	180	136
	6	11	3535	25-90	-	89	36,25	180	161,5
	8	11	3535	25-90	-	89	62	180	212,5
250	3	11	3020	22-75	-	51	17	194	85
	4	11	3535	25-90	-	89	10,75	198	110,5
	5	11	3535	25-90	-	89	23,5	198	136
	6	11	3535	25-90	-	89	36,25	198	161,5
	8	11	3535	25-90	-	89	61,75	198	212,5
265	3	1	3535	25-90	175	89	4	-	85
	4	11	3535	25-90	-	89	11	209	110,5
	5	11	3535	25-90	-	89	23,5	209	136
	6	11	3535	25-90	-	89	36,5	209	161,5
	8	11	3535	25-90	-	89	62	209	212,5
280	3	1	3535	49-90	175	89	4	-	85
	4	6	3535	25-90	175	89	10,75	228	110,5
	5	6	3535	25-90	-	89	23,5	224	136
	6	6	3535	25-90	175	89	36,25	228	161,5
	8	11	3535	25-90	-	89	62	224	212,5
300	3	12	3535	25-90	175	89	2	244	85
	4	6	3535	25-90	175	89	10,75	244	110,5
	5	6	3535	25-90	175	89	23,5	247	136
	6	6	3535	25-90	175	89	36,25	247	161,5
	8	11	4040	40-100	-	102	55,5	244	212,5
315	3	12	3535	25-90	175	89	2	259	85
	4	6	3535	25-90	175	89	11	259	110,5
	5	6	3535	25-90	175	89	23,5	279	136
	-	-	-	-	-	-	-	-	-
	8	11	4040	40-100	-	102	55,5	259	212,5
335	3	3	3535	25-90	175	89	2	279	85
	4	9	3535	25-90	175	89	11	279	110,5
	5	6	3535	25-90	175	89	23,5	279	136
	6	6	3535	25-90	175	89	36,5	279	161,5
	8	6	4040	40-100	210	102	55,25	282	212,5
355	3	3	3535	25-90	175	89	2	299	85
	4	9	3535	25-90	175	89	11	299	110,5
	5	9	3535	25-90	175	89	23,5	299	136
	6	6	3535	25-90	175	89	36,5	299	161,5
	8	6	4040	40-100	216	102	55,5	299	212,5
400	3	3	3535	25-90	178	89	2	342	85
	4	9	3535	25-90	178	89	10,75	342	110,5
	5	9	3535	25-90	175	89	23,5	342	136
	6	6	4040	40-100	215	102	29,75	342	161,5
	8	6	4545	55-110	242	114	49,5	344	212,5
450	3	3	3535	25-90	178	89	2	393	85
	4	9	3535	25-90	178	89	10,75	393	110,5
	5	9	4040	40-100	215	102	17	393	136
	-	-	-	-	-	-	-	-	-
	8	6	5050	50-125	267	127	43	393	212,5

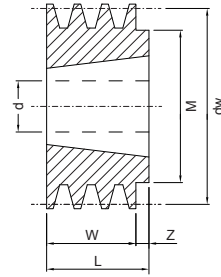

1

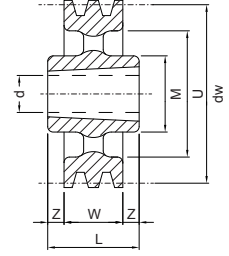

3

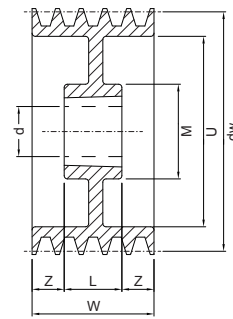

6

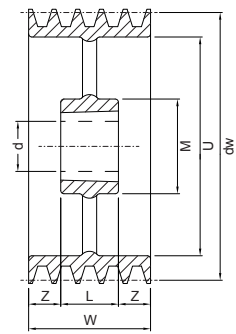

9

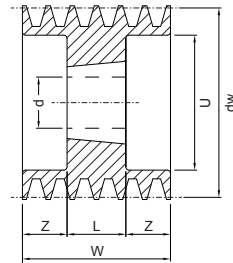

11

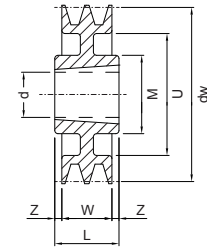

12

Dimensions des poulies à gorges trapézoïdales PBT - moyeu amovible SER-SIT®



» "PBT" SPC-C

dw [mm]	Nb de gorges	Type	Moyeu amovible SER-SIT®	d min-max [mm]	M [mm]	L [mm]	Z [mm]	U [mm]	W [mm]
475	3	3	3535	25-90	170	89	2	419	85
500	3	3	3535	25-90	178	89	2	443	85
	4	9	3535	25-90	175	89	11	443	110,5
	5	9	4040	40-100	215	102	17	443	136
	6	9	4545	55-110	242	114	24	443	161,5
560	-	-	-	-	-	-	-	-	-
	3	3	3535	25-90	178	89	2	503	85
	4	9	4040	40-100	215	102	4,25	503	110,5
	5	9	4545	55-110	242	114	11	503	136
	6	9	5050	50-125	267	127	17,25	503	161,5
630	8	9	5050	50-125	267	127	42,75	503	212,5
	3	3	4040	40-100	215	102	8,5	573	85
	4	9	4545	55-110	242	114	1,5	573	110,5
	5	9	5050	50-125	267	127	4,5	573	136
710	6	9	5050	50-125	265	127	17,75	573	161,5
	8	9	5050	50-125	267	127	42,75	573	212,5
	3	3	4040	40-100	215	102	8,5	654	85
	4	3	5050	50-125	267	127	8	654	110,5
800	5	9	5050	50-125	265	127	4,5	654	136
	6	9	5050	50-125	265	127	17,25	654	161,5
	8	9	5050	50-125	265	127	43,75	654	212,5
	3	3	4545	55-110	240	114	14,5	737	85
1000	4	3	5050	50-125	265	127	8,25	737	110,5
	5	9	5050	50-125	265	127	4,5	737	136
	6	9	5050	50-125	265	127	17,25	737	161,5
	8	9	5050	50-125	265	127	42,75	737	212,5
1250	3	3	5050	50-125	267	126	20,5	1190	85
	4	3	5050	50-125	267	126	7,75	1190	110,5
	5	9	5050	50-125	280	127	4,5	1190	136
	6	9	5050	50-125	280	127	17,25	1190	161,5
8	9	5050	50-125	280	127	42,75	1190	212,5	

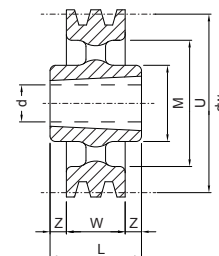

3

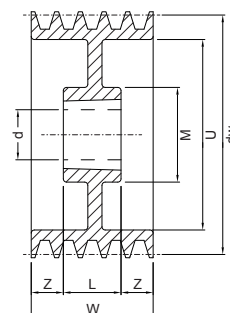

6

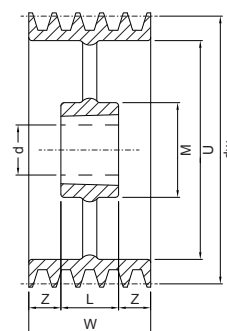

9

Dimensions des poulies à gorges trapézoïdales PCT - avec moyeu surdimensionné pour moyeux de serrage



Poulies à gorges trapézoïdales pour moyeu hors dimension avec les moyeux de serrage **SIT-LOCK® CAL 8**.
La tolérance d'alésage est H8.

PCT SPA

dw [mm]	Nb de gorges	Type	d min-max [mm]	M [mm]	U [mm]	L [mm]	W [mm]	Z [mm]
090	2	2	55	-	-	35	35	-
100	2	2	65	-	-	35	35	-
	3	2	55	-	-	50	50	-
160	3	1	55	-	127	27	50	23,0
180	2	4	65	120	147	27	35	4,0
225	2	4	55	120	192	27	35	4,0

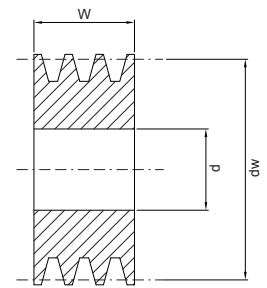
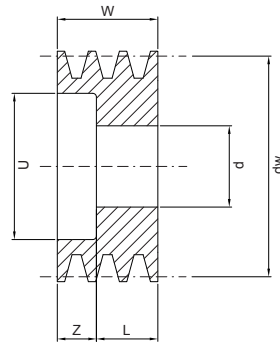

1

2

PCT SPB

dw [mm]	Nb de gorges	Type	d min-max [mm]	M [mm]	U [mm]	L [mm]	W [mm]	Z [mm]
120	2	1	65	-	78	27	44	17,0
125	4	1	55	-	83	27	82	55,0
130	3	1	80	-	88	27	63	35,0
	4	1	80	-	88	27	82	65,0
	5	1	80	-	88	27	101	74,0
140	2	1	65	-	98	27	44	17,0
	3	1	65	-	98	27	63	36,0
	4	1	65	-	98	27	82	55,0
150	2	1	65	-	108	27	44	17,0
	3	1	55	-	108	27	63	36,0
	3	1	65	-	108	27	63	36,0
	3	1	80	-	108	27	63	36,0
	4	1	80	-	108	27	82	55,0
160	3	1	80	-	118	27	63	36,0
	4	1	80	-	118	27	82	55,0
	5	1	80	-	118	27	101	74,0
170	2	3	80	-	128	27	44	8,5
	4	4	80	120	128	27	82	27,5
180	3	4	80	120	138	27	63	18,0
	4	4	80	120	138	27	82	27,5
	5	4	80	120	138	27	101	37,0
190	2	4	80	120	148	27	44	8,5
	4	4	80	120	148	27	82	27,5
200	3	4	80	120	158	27	63	18,0
	4	4	80	120	158	27	82	27,5
	5	4	80	120	158	27	101	37,0
212	4	4	80	120	170	27	82	27,5
	5	4	80	120	170	27	82	27,5
225	2	4	80	120	183	27	44	8,5
	3	4	80	120	183	27	63	18,0
	4	4	80	120	183	27	82	27,5
	5	4	80	120	183	27	101	37,0
250	3	4	80	120	208	27	63	18,0
	4	4	80	120	208	27	82	27,5
	5	4	80	130	208	27	101	37,0
280	4	4	80	120	238	27	82	27,5
	5	4	80	120	238	27	101	37,0
315	5	5	80	140	273	27	101	37,0

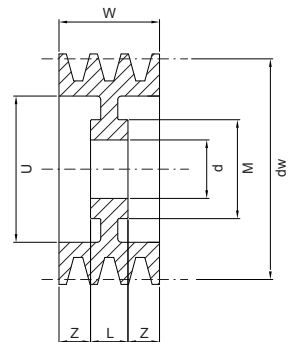
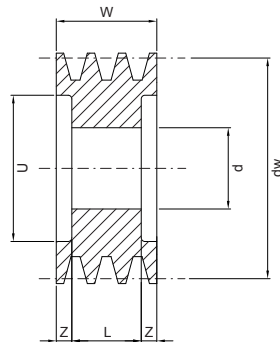

3

4

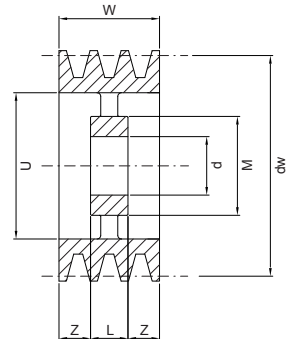

5

SIT-LOCK® 8 - Auto-centré - Diamètre extérieur spécial

Moyeu d'assemblage à simple cône. Le concept à bride interdit tout débattement axial en cours de montage.

Le moyeu d'assemblage SIT-LOCK® 8 comporte une très petite dimension axiale, un centrage automatique et a été conçu pour une adaptation à divers diamètres d'arbres tout en conservant ses dimensions hors tout.

Le moyeu d'assemblage SIT-LOCK® 8 est recommandé pour les applications avec couples moyens nécessitant un bon positionnement axial.

Le nombre limité de vis réduit considérablement le temps de montage.

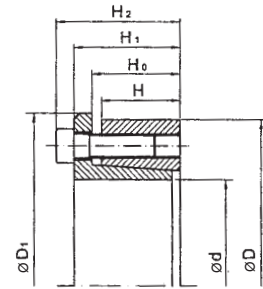
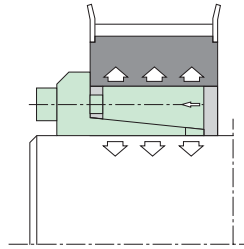

SIT-LOCK® 8

Dimensions [mm]						Performances		Pression [N/mm ²]		Vis de fixation (DIN 912 - 12,9)		
d x D	H	H ₀	H ₁	H ₂	D ₁	M _T [Nm]	F _{ax} [kN]	p _w	p _n	N°	Type	M _s [Nm]
14 x 55	17	22	30	38	62	130	19	208	53	3	M8	25
16 x 55	17	22	30	38	62	149	19	182	53	3	M8	25
18 x 55	17	22	30	38	62	168	19	162	53	3	M8	25
19 x 55	17	22	30	38	62	177	19	153	53	3	M8	25
20 x 55	17	22	30	38	62	186	19	145	53	3	M8	25
22 x 55	17	22	30	38	62	288	26	186	74	3	M8	35
24 x 55	17	22	30	38	62	314	26	170	74	3	M8	35
25 x 55	17	22	30	38	62	328	26	164	74	3	M8	35
28 x 55	17	22	30	38	62	441	32	176	89	3	M8	41
30 x 55	17	22	30	38	62	473	32	164	89	3	M8	41
24 x 65	17	23	31	39	72	448	37	243	90	5	M8	30
25 x 65	17	23	31	39	72	467	37	233	90	5	M8	30
28 x 65	17	23	31	39	72	611	44	243	105	5	M8	35
30 x 65	17	23	31	39	72	655	44	227	105	5	M8	35
32 x 65	17	23	31	39	72	699	44	213	105	5	M8	35
35 x 65	17	23	31	39	72	919	53	234	126	5	M8	41
38 x 65	17	23	31	39	72	998	53	216	126	5	M8	41
40 x 65	17	23	31	39	72	1.051	53	205	126	5	M8	41
30 x 80	20	26	34	42	87	785	52	231	87	7	M8	30
32 x 80	20	26	34	42	87	837	52	217	87	7	M8	30
33 x 80	20	26	34	42	87	863	52	210	87	7	M8	30
35 x 80	20	26	34	42	87	1.070	61	232	101	7	M8	35
38 x 80	20	26	34	42	87	1.162	61	213	101	7	M8	35
40 x 80	20	26	34	42	87	1.223	61	203	101	7	M8	35
42 x 80	20	26	34	42	87	1.544	74	232	122	7	M8	41
45 x 80	20	26	34	42	87	1.655	74	217	122	7	M8	41
48 x 80	20	26	34	42	87	1.765	74	203	122	7	M8	41
50 x 80	20	26	34	42	87	1.838	74	195	122	7	M8	41

otes

Les dimensions représentant la longueur totale du moyeu sont indicatives; elles sont calculées selon les règles géométriques. Pour les assemblages de dimensions plus importantes, contactez notre service technique.

M _s	Couple de serrage des vis	Nm
M _T	Moment de couple transmissible	Nm
F _{ax}	Charge axiale transmissible	N
p _w	Pression de l'arbre	N/mm ²
p _n	Pression du moyeu	N/mm ²

Poulies réglables à l'arrêt

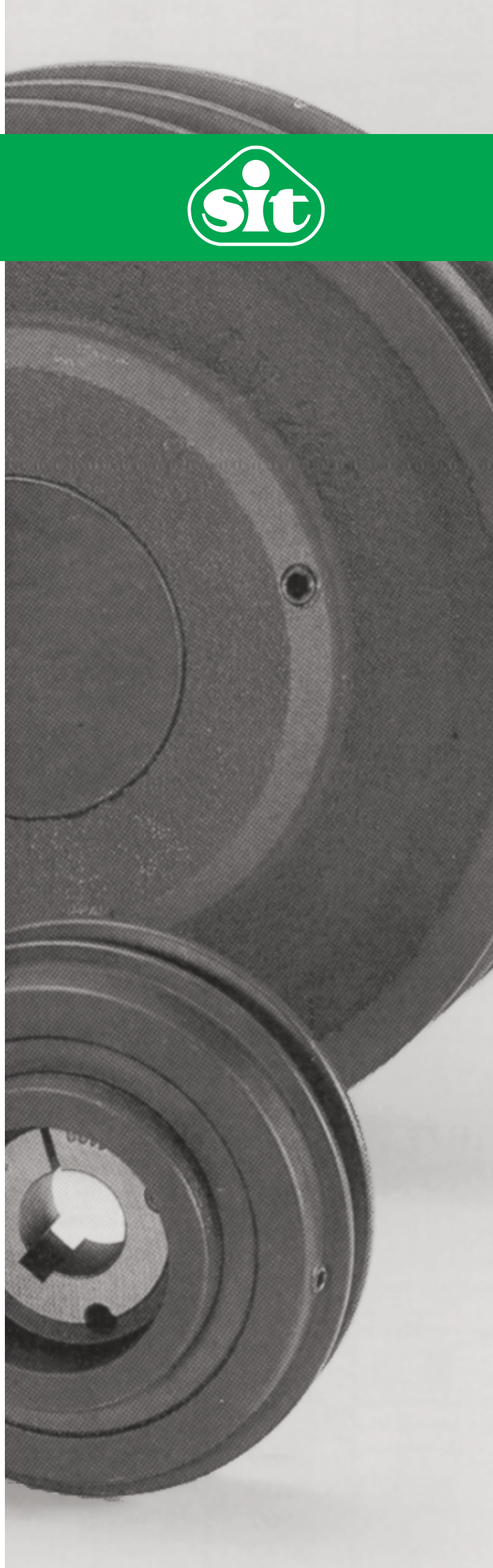

Poulies réglables SIT "PR DV" et "PBR DV"

Les poulies réglables "PR DV" et "PBR DV" sont conçues pour permettre un réglage du diamètre primitif. Une bride est vissée sur le moyeu fileté, la flasque mobile est munie de vis de réglage pour ajuster la position. Il est conseillé de graisser périodiquement le filetage du moyeu. Elles conviennent pour les sections Z-SPZ-3V; UN SPA; B-SPB-5V; C-SPC des courroies trapézoïdales.

En ce qui concerne la puissance nominale, veuillez consulter notre catalogue de courroies trapézoïdales, en faisant attention au diamètre minimum autorisé selon la section et le type de courroie sélectionnée.

Poulies PR DV - moyeu plein

Matière : fonte.

Finition: phosphatation au manganèse noir.

Poulies trapézoïdales adaptées à un usage normal avec les courroies suivantes :

- 1DV
- 2DV



Poulies PBR DV - pour moyeux amovibles SER-SIT®

Matière : fonte.

Finition: phosphatation au manganèse noir.

Poulies trapézoïdales adaptées à un usage normal avec les courroies suivantes

- 1DV
- 2DV



Note

En raison de l'amélioration constante de nos produits, les données techniques des poulies peuvent faire l'objet de modifications.

Dimensions des poulies réglables PR DV - moyeu plein

PR 1DV

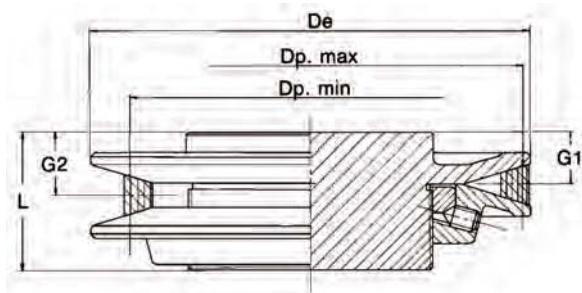

Désignation

PR 1DV 121

Poulie réglable PR moyeu plein

Nombre de gorges (1 gorge)

Diamètre extérieur [mm]



Code	De [mm]	L [mm]	Courroie SPZ					Courroie SPA					Courroie SPB				
			Dp max [mm]	Dp min [mm]	Variation	G1 [mm]	G2 [mm]	Dp max [mm]	Dp min [mm]	Variation	G1 [mm]	G2 [mm]	Dp max [mm]	Dp min [mm]	Variation	G1 [mm]	G2 [mm]
PR1DV 59	59	36	54	38	1,42	11	13,4	53,4	40	1,34	12,5	14,5	-	-	-	-	-
PR1DV 73	73	40	68	52	1,31	14	16,4	67,4	54	1,25	15,5	17,5	66	60	1,1	16,8	17,7
PR1DV 83	83	46,5	71,5	56	1,27	16,5	18,9	77,4	58	1,33	17	20	76	64	1,19	18,3	20,2
PR1DV 95	95	46,5	83,5	68	1,23	16,5	18,9	89,4	70	1,28	17	20	88	76	1,16	18,3	20,2
PR1DV 105	105	47	90	74,5	1,21	17	19,4	99,4	77	1,29	17	20,5	98	82,5	1,19	18,3	20,7
PR1DV 121	121	48	106	90,5	1,17	17	19,4	115,4	93	1,24	17	20,5	114	98,5	1,16	18,3	20,7
PR1DV 136	136	48	121	105,5	1,15	17	19,4	130,4	108	1,21	17	20,5	129	113,5	1,14	18,3	20,7
PR1DV 152	152	48	137	121,5	1,13	17	19,4	146,4	124	1,18	17	20,5	145	129,5	1,12	18,3	20,7
PR1DV 167	167	48	152	136,5	1,11	17	19,4	161,4	139	1,16	17	20,5	160	144,5	1,11	18,3	20,7
PR1DV 232	232	59,5	206,5	184,5	1,12	25	27,1	220	197	1,12	25	28	221	202,5	1,09	25,0	28,2

PR 2DV

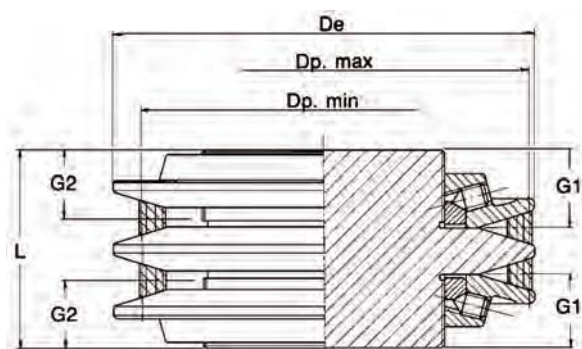

Code	De [mm]	L [mm]	Courroie SPZ					Courroie SPA					Courroie SPB				
			Dp max [mm]	Dp min [mm]	Variation	G1 [mm]	G2 [mm]	Dp max [mm]	Dp min [mm]	Variation	G1 [mm]	G2 [mm]	Dp max [mm]	Dp min [mm]	Variation	G1 [mm]	G2 [mm]
PR2DV 105	105	76	90	74,5	1,21	30	27,6	99,4	77	1,29	30	26,5	98	82,5	1,19	30	27,6
PR2DV 121	121	76	106	90,5	1,17	30	27,6	115,4	93	1,24	30	26,5	114	98,5	1,16	30	27,6
PR2DV 136	136	76	121	105,5	1,15	30	27,6	130,4	108	1,21	30	26,5	129	113,5	1,14	30	27,6
PR2DV 152	152	76	137	121,5	1,13	30	27,6	146,4	124	1,18	30	26,5	145	129,5	1,12	30	27,6
PR2DV 167	167	76	152	136,5	1,11	30	27,6	161,4	139	1,16	30	26,5	160	144,5	1,11	30	27,6
PR2DV 232	232	90	206,5	184,5	1,12	34,5	32,4	220	197	1,12	34,5	31,5	221	202,5	1,09	34,5	31,3

Dimensions des poulies PBR DV - moyeu amovible SER-SIT®

PBR 1DV

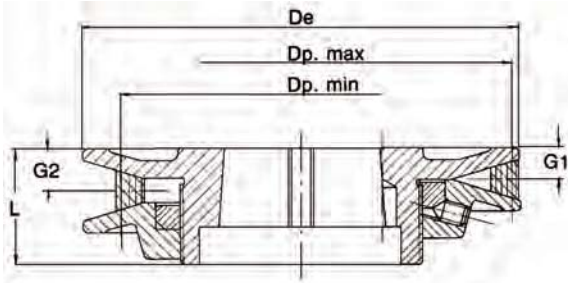

Désignation

PBR 2DV 121

Poulie réglable pour moyeu amovible PBR

Nombre de gorges (2 gorges)

Diamètre extérieur [mm]



Code	De [mm]	L [mm]	Moyeu amovible SER-SIT®	Courroie SPZ					Courroie SPA					Courroie SPB				
				Dp max [mm]	Dp min [mm]	Variation	G1 [mm]	G2 [mm]	Dp max [mm]	Dp min [mm]	Variation	G1 [mm]	G2 [mm]	Dp max [mm]	Dp min [mm]	Variation	G1 [mm]	G2 [mm]
PBR1DV 95	95	39,5	1008 (25.20)	83,5	68	1,23	9,5	11,9	89,4	70	1,28	10	13	88	76	1,16	11,3	13,2
PBR1DV 105	105	40	1108 (28.20)	90	74,5	1,21	10	12,4	99,4	77	1,29	10	13,5	98	82,5	1,19	11,3	13,7
PBR1DV 121	121	41	1108 (28.20)	106	90,5	1,17	10	12,4	115,4	93	1,24	10	13,5	114	98,5	1,16	11,3	13,7
PBR1DV 136	136	41	1210 (30.25)	121	105,5	1,15	10	12,4	130,4	108	1,21	10	13,5	129	113,5	1,14	11,3	13,7
PBR1DV 152	152	41	1610 (40.25)	137	121,5	1,13	10	12,4	146,4	124	1,18	10	13,5	145	129,5	1,12	11,3	13,7
PBR1DV 167	167	41	1610 (40.25)	152	136,5	1,11	10	12,4	161,4	139	1,16	10	13,5	160	144,5	1,11	11,3	13,7
PBR1DV 232	232	47,5	2012 (50.30)	206,5	184,5	1,12	13	15,1	220	197	1,12	13	16	221	202,5	1,09	13	16,2

PBR 2DV

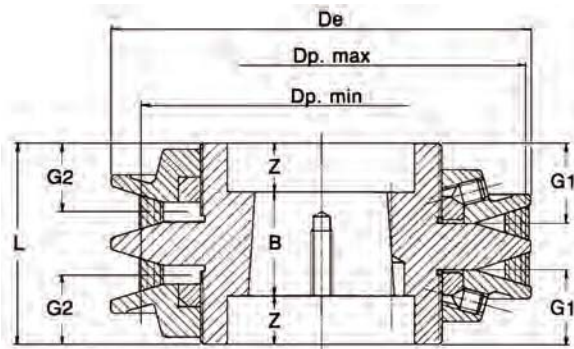

Code	De [mm]	L [mm]	Z [mm]	B [mm]	Moyeu amovible SER-SIT®	Courroie SPZ					Courroie SPA					Courroie SPB				
						Dp max [mm]	Dp min [mm]	Variation	G1 [mm]	G2 [mm]	Dp max [mm]	Dp min [mm]	Variation	G1 [mm]	G2 [mm]	Dp max [mm]	Dp min [mm]	Variation	G1 [mm]	G2 [mm]
PBR2DV 105	105	76	27	22	1108 (28.20)	90	74,5	1,21	30	27,6	99,4	77	1,29	30	26,5	98	82,5	1,19	30	27,6
PBR2DV 121	121	76	17	42	1215 (30.40)	106	90,5	1,17	30	27,6	115,4	93	1,24	30	26,5	114	98,5	1,16	30	27,6
PBR2DV 136	136	76	17	42	1215 (30.40)	121	105,5	1,15	30	27,6	130,4	108	1,21	30	26,5	129	113,5	1,14	30	27,6
PBR2DV 152	152	76	17	42	1615 (40.40)	137	121,5	1,13	30	27,6	146,4	124	1,18	30	26,5	145	129,5	1,12	30	27,6
PBR2DV 167	167	76	17	42	1615 (40.40)	152	136,5	1,11	30	27,6	161,4	139	1,16	30	26,5	160	144,5	1,11	30	27,6
PBR2DV 232	232	90	21,5	47	2517 (65.45)	206,5	184,5	1,12	34,5	32,4	220	197	1,12	34,5	31,5	221	202,5	1,09	34,5	31,3

Poulies variables



Description - Poulies VAR

Les poulies à vitesse variable ont fait leurs preuves dans les entraînements, conçues pour varier de vitesse en continu, à un relativement faible coût.

Cependant cette conception est soumise à une usure des flasques excessive en raison du type de systèmes d'entraînement utilisés.

- Le moyeu est fabriqué à partir d'acier trempé par induction, chromé pour assurer une glisse ininterrompue avec la flasque. Pas de clavette avec cette application.

- Les flasques mobiles offrent une large zone de contact éliminant ainsi toute inégalité de pression sur la courroie.

- Les flasques sont couplées au moyeu par des manchons en nylon à l'extérieur des flasques et par deux arêtes usinées à chaque extrémité du moyeu de la poulie. Deux ressorts situés à l'intérieur du raccord en nylon exercent la pression souhaitée.

- Re-graissez les gorges de la poulie, bien que les chambres à graisse soient pré emplies avant de quitter l'usine.

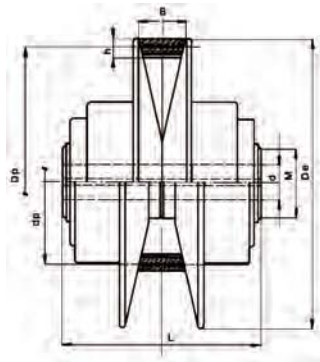

Désignation	PV 160	VAR 22
Poulie variable		
Diamètre externe [mm]		
Type "VAR"		
Diamètre d'alésage fini [mm]		

Type	Puissance				Courroie a x b [mm]	De [mm]	L [mm]	Dw		Moyeu et alésages			Variation	Poids [Kg]
	750 [rpm]	1000 [rpm]	1500 [rpm]	3000 [rpm]				Max Dp [mm]	Min dp [mm]	M (1) [mm]	d (2) [mm]	Alésages finis (3) [mm]		
VAR 100	0,25	0,33	0,50	1	13 x 6	100	65	97	37	23	10	11-12-14-16	2,61	0,90
VAR 130	0,37	0,50	0,75	1,5	22 x 8	130	88	126	46	27	10	14-18-19	2,73	1,69
VAR 160	0,75	1,0	1,50	3	28 x 10	160	115	155	60	34	10	18-19-22-24	2,58	3,25
VAR 190	1,75	2,30	3,50	7	36 x 12	190	131	184	65	39	10	19-22-24-25-28	2,83	4,85
VAR 240	2,75	3,65	5,50	-	46 x 13	240	170	233	72	43	10	24-25-28-32	3,22	8,60
VAR 300	5,00	6,60	10,0	-	54 x 16	300	200	292	91	54	10	32-38-42	3,21	15,00

(1) Diamètre moyeu acier (2) Tolérance de diamètre de l'alésage pilote H11 (3) Diamètre des alésages H7 avec rainure de clavette UNI

Instructions d'installation

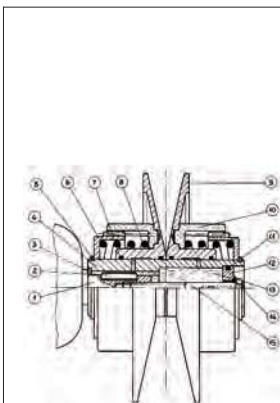

1	Arbre moteur
2	Clavette
3	Rondelle d'étanchéité alu
4	Arbre de la poulie
5	Rondelle d'arrêt
6	Douille dentée
7	Joint OR
8	Ressort
9	Flasque
10	Manchon SM/23
11	Joint OR
12	Rondelle en acier
13	Graisse de lubrification
14	Rondelle d'étanchéité alu
15	Vis

Opérations

1	Déposer la Clavette (2) de l'Arbre moteur (1)
2	Monter la Rondelle d'étanchéité en aluminium (3) sur l'Arbre moteur (1)
3	Repositionner la Clavette (2) dans l'Arbre moteur (1)
4	Monter la poulie
5	Verrouiller l'Arbre moteur (1) avec la Vis (15) sans oublier la Rondelle d'étanchéité en aluminium (14)
6	IMPORTANT Remplir la chambre à graisse avec la Graisse de lubrification (13). Préférentiellement de la graisse épaisse.

Description - Poulies FIXED

La poulie à entraînement fixe a été spécifiquement conçue pour être utilisée avec des poulies VAR. Elles sont fabriquées en fonte grise (GG20 - GG25) et traitées avec un procédé de phosphatation au manganèse noir.

Désignation	PF 160/46
Poulie FIXED	
Diamètre externe [mm] / Largeur de la gorge [mm]	

Type	FIXED 100	FIXED 130	FIXED 160	FIXED 190	FIXED 240	FIXED 300
α	25°	25°	25°	28°	28°	28°
h [mm]	12	16	18	20	26	32
l [mm]	13	22	28	36	46	54
L [mm]	20	26	32	43	52	70
Diamètre p [mm]	Diamètre du moyeu m [mm]					
80	30	30	35	-	-	-
90	35	38	38	-	-	-
100	35	38	38	-	-	-
112	40	42	42	50	-	-
125	40	46	46	54	-	-
140	40	48	48	54	55	-
160	45	48	48	60	68	-
170	45	55	55	62	70	-
180	50	58	58	68	75	80
200	50	68	68	70	78	82
224	60	70	70	70	85	90
250	60	70	75	75	88	92
280	60	70	78	78	90	92
315	60	80	80	80	90	100
355	-	85	90	90	90	95
400	-	-	90	90	90	95
450	-	-	-	90	95	95
500	-	-	-	-	95	105

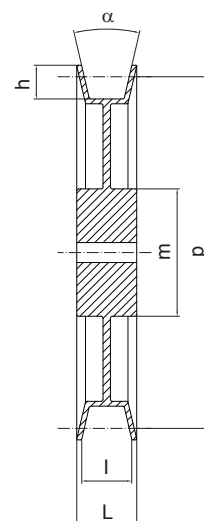

Plage de vitesse et entraxes des ensembles VAR et FIXED

VAR 100

Longueur du pas [mm]	Plage de vitesse - entraxes																													
	Gamme de vitesse en tours par minute de la poulie entraînée par une poulie VAR (tr/nm)								Longueur intérieure des courroies en mm																					
	750		1000		1500		3000		500	525	550	600	650	675	700	750	800	850	900	950	1000	1060	1120	1180	1250	1320	1400	1500	1600	
	Min.	Max.	Min.	Max.	Min.	Max.	Min.	Max.	Entraxe en mm pour des courroies 13X6																					
80	876	355	1168	447	1752	671	3505	1343	122	135	147	172	197	210	222	247	272	297	322	347	372	402	432	462	497	532	572	-	-	
90	782	299	1042	399	1564	599	3128	1199	115	127	140	165	190	202	215	240	265	290	315	340	365	395	425	455	490	525	565	-	-	
100	706	270	941	360	1412	541	2825	1082	-	119	132	157	182	194	207	232	257	282	307	332	357	387	417	447	482	517	557	-	-	
112	632	242	843	323	1265	485	2530	970	-	-	122	147	172	185	197	222	247	272	297	322	347	377	407	437	472	507	547	-	-	
125	568	217	758	290	1137	435	2274	871	-	-	-	136	161	174	186	212	237	262	287	312	337	367	397	427	462	497	537	-	-	
140	508	195	678	260	1017	390	2035	780	-	-	-	-	149	161	174	199	224	249	274	299	324	355	385	415	450	485	525	-	-	
160	446	171	595	228	893	342	1786	684	-	-	-	-	-	143	156	182	207	232	257	283	308	338	368	398	433	468	509	-	-	
170	420	161	561	215	841	322	1683	645	-	-	-	-	-	-	147	173	198	224	249	274	299	330	360	390	425	460	500	-	-	
180	397	152	530	203	795	304	1591	609	-	-	-	-	-	-	-	163	189	215	240	265	291	321	351	381	417	452	492	-	-	
200	358	137	478	183	717	274	1434	549	-	-	-	-	-	-	-	-	170	196	222	248	273	304	334	364	400	435	475	-	-	
224	320	122	427	163	641	245	1282	491	-	-	-	-	-	-	-	-	-	-	199	225	251	282	313	343	379	414	455	-	-	
250	287	110	383	147	575	220	1151	441	-	-	-	-	-	-	-	-	-	-	-	199	225	257	288	319	355	391	432	-	-	
280	257	98	343	131	514	197	1029	394	-	-	-	-	-	-	-	-	-	-	-	-	164	193	226	259	290	327	363	405	-	-
315	228	87	305	117	457	175	915	351	-	-	-	-	-	-	-	-	-	-	-	-	-	-	-	220	254	292	329	371	-	-

VAR 130

Longueur du pas [mm]	Plage de vitesse - entraxes																													
	Gamme de vitesse en tours par minute de la poulie entraînée par une poulie VAR (tr/nm)								Longueur intérieure des courroies en mm																					
	750		1000		1500		3000		500	525	550	600	650	675	700	750	800	850	900	950	1000	1060	1120	1180	1250	1320	1400	1500	1600	
	Min.	Max.	Min.	Max.	Min.	Max.	Min.	Max.	Entraxe en mm pour des courroies 22x8																					
80	1124	410	1498	547	2248	821	4496	1642	-	-	-	152	177	190	202	227	252	277	303	328	353	383	413	443	478	513	553	603	653	
90	1004	367	1339	489	2009	734	4019	1468	-	-	-	145	170	182	195	220	245	270	295	320	345	375	405	435	470	505	545	595	645	
100	908	331	1211	442	1816	663	3633	1327	-	-	-	137	162	175	187	212	237	262	287	312	337	367	397	427	462	497	537	587	637	
112	814	297	1086	396	1629	595	3258	1190	-	-	-	128	153	166	178	203	228	253	278	303	328	358	388	418	453	488	528	578	628	
125	732	267	976	356	1465	535	2930	1070	-	-	-	-	143	155	168	193	218	243	268	293	318	348	378	408	443	478	518	568	618	
140	656	239	875	319	1312	479	2625	959	-	-	-	-	-	-	156	181	206	231	256	281	306	336	366	396	431	466	506	556	606	
160	576	210	768	280	1152	421	2305	842	-	-	-	-	-	-	-	164	190	215	240	265	290	320	350	380	415	450	490	540	590	
170	543	198	724	264	1086	396	2173	793	-	-	-	-	-	-	-	-	181	206	231	256	282	312	342	372	407	442	482	532	582	
180	513	187	685	250	1027	375	2055	750	-	-	-	-	-	-	-	-	172	198	223	248	273	303	333	364	399	434	474	524	574	
200	463	169	617	225	926	338	1853	677	-	-	-	-	-	-	-	-	-	180	205	231	256	286	317	347	382	417	457	508	558	
224	414	151	552	202	829	303	1658	606	-	-	-	-	-	-	-	-	-	-	-	209	235	265	296	326	362	397	437	488	538	
250	372	136	496	181	744	272	1498	544	-	-	-	-	-	-	-	-	-	-	-	-	-	210	241	272	303	339	374	415	465	516
280	333	121	444	162	666	243	1332	486	-	-	-	-	-	-	-	-	-	-	-	-	-	-	-	243	275	311	347	388	439	490
315	296	108	395	144	592	216	1185	433	-	-	-	-	-	-	-	-	-	-	-	-	-	-	-	-	239	277	314	356	407	459
355	263	96	351	128	526	192	1053	385	-	-	-	-	-	-	-	-	-	-	-	-	-	-	-	-	-	272	316	369	421	

POULIES VARIABLES - PV

VAR 160

ø primitif [mm]	Plage de vitesse - entraxes																													
	Gamme de vitesse en tours par minute de la poulie entraînée par une poulie VAR (tr/nm)								Longueur intérieure des courroies en mm																					
	750		1000		1500		3000		500	525	550	600	650	675	700	750	800	850	900	950	1000	1060	1120	1180	1250	1320	1400	1500	1600	
	Min.	Max.	Min.	Max.	Min.	Max.	Min.	Max.	Entraxe en mm pour des courroies 28x10																					
80	1384	535	1846	714	2769	1071	5538	2143	131	156	182	207	233	258	283	308	334	364	394	424	459	494	534	584	634	685	735	835	-	
90	1237	478	1649	638	2474	957	4948	1915	-	149	175	200	226	251	276	301	326	356	386	416	452	487	527	577	627	677	727	827	-	
100	1118	432	1490	577	2236	865	4472	1731	-	142	168	193	218	243	269	294	319	349	379	409	444	479	519	569	619	669	719	819	-	
112	1002	387	1336	517	2004	775	4009	1551	-	-	159	184	209	234	260	285	310	340	370	400	435	470	510	560	610	660	710	810	-	
125	901	348	1201	465	1802	697	3605	1395	-	-	-	175	200	225	250	275	300	330	360	390	425	460	500	550	600	650	700	800	-	
140	807	312	1076	416	1614	624	3229	1249	-	-	-	-	188	213	238	263	288	318	348	378	413	448	488	538	588	638	688	788	-	
160	708	274	945	365	1417	548	2835	1097	-	-	-	-	-	198	223	248	273	303	333	363	398	433	473	523	573	623	673	773	-	
170	668	258	890	344	1336	517	2672	1034	-	-	-	-	-	190	215	240	265	295	325	355	390	425	465	515	565	615	665	765	-	
180	631	244	842	326	1263	489	2526	978	-	-	-	-	-	181	206	231	256	287	317	347	382	417	457	507	557	607	657	757	-	
200	569	220	759	294	1139	441	2279	882	-	-	-	-	-	-	215	240	270	300	330	365	400	441	491	541	591	641	741	-	-	
224	509	197	679	263	1019	394	2039	789	-	-	-	-	-	-	-	219	250	270	310	345	381	421	471	521	571	621	721	-	-	
250	457	177	610	236	915	354	1830	708	-	-	-	-	-	-	-	-	227	257	288	323	359	399	449	499	550	600	700	-	-	
280	409	158	545	211	818	316	1636	633	-	-	-	-	-	-	-	-	-	229	250	296	332	373	423	474	524	575	675	-	-	
315	364	141	485	188	728	282	1457	564	-	-	-	-	-	-	-	-	-	-	-	263	300	341	392	443	494	545	646	-	-	
355	323	125	431	167	647	250	1294	501	-	-	-	-	-	-	-	-	-	-	-	-	-	-	302	355	407	458	509	611	-	-
400	287	111	383	148	575	222	1150	445	-	-	-	-	-	-	-	-	-	-	-	-	-	-	-	309	363	415	468	571	-	-

VAR 190

ø primitif [mm]	Plage de vitesse - entraxes																													
	Gamme de vitesse en tours par minute de la poulie entraînée par une poulie VAR (tr/nm)								Longueur intérieure des courroies en mm																					
	750		1000		1500		3000		500	525	550	600	650	675	700	750	800	850	900	950	1000	1060	1120	1180	1250	1320	1400	1500	1600	
	Min.	Max.	Min.	Max.	Min.	Max.	Min.	Max.	Entraxe en mm pour des courroies 36x12																					
112	1189	419	1586	559	2379	838	4759	1677	-	-	-	-	189	214	240	265	290	320	350	380	416	451	491	541	591	641	691	791	911	
125	1069	377	1426	502	2139	754	4279	1508	-	-	-	-	180	205	230	255	280	311	341	371	406	441	481	531	581	631	681	781	901	
140	958	337	1277	450	1916	675	3833	1350	-	-	-	-	194	219	244	269	299	329	359	394	429	470	520	570	620	670	770	890	-	
160	841	296	1121	395	1682	593	3365	1186	-	-	-	-	-	204	229	254	284	314	344	379	414	454	504	554	604	654	754	874	-	
170	793	279	1057	372	1586	558	3172	1117	-	-	-	-	-	196	221	246	276	306	336	371	406	446	496	546	596	646	746	866	-	
180	750	264	1000	352	1500	528	3000	1057	-	-	-	-	-	-	214	239	269	299	329	364	399	439	489	539	589	639	739	859	-	
200	676	238	901	317	1352	476	2705	953	-	-	-	-	-	-	-	223	253	283	313	348	383	423	473	523	573	623	723	843	-	
224	605	213	806	284	1210	426	2420	853	-	-	-	-	-	-	-	-	233	263	293	328	363	403	453	504	554	604	704	824	-	
250	543	191	724	255	1086	382	2173	765	-	-	-	-	-	-	-	-	-	241	271	307	342	382	432	482	532	583	683	803	-	
280	485	171	647	228	971	342	1943	684	-	-	-	-	-	-	-	-	-	-	245	281	316	357	407	457	508	558	658	778	-	
315	432	152	576	203	865	304	1730	609	-	-	-	-	-	-	-	-	-	-	-	-	-	326	376	427	478	528	629	749	-	
355	384	135	512	180	768	270	1537	541	-	-	-	-	-	-	-	-	-	-	-	-	-	-	288	340	391	442	493	595	716	-
400	341	120	455	160	683	240	1366	481	-	-	-	-	-	-	-	-	-	-	-	-	-	-	-	348	401	452	555	677	-	-
450	303	107	405	142	607	214	1215	428	-	-	-	-	-	-	-	-	-	-	-	-	-	-	-	-	351	404	509	632	-	-

VAR 240

Longueur du pas [mm]	Plage de vitesse - entraxes																		
	Gamme de vitesse en tours par minute de la poulie entraînée par une poulie VAR (tr/nm)						Longueur intérieure des courroies en mm												
	750		1000		1500		995	1055	1115	1175	1245	1315	1395	1495	1595	1695	1795	2000	2240
	Min.	Max.	Min.	Max.	Min.	Max.	Entraxe en mm pour des courroies 46x13												
140	1195	371	1594	494	2391	742	225	256	286	316	352	387	427	477	528	578	628	731	851
160	1052	326	1402	435	2104	653	-	241	272	302	337	372	412	462	513	563	613	715	835
170	992	308	1323	410	1984	616	-	234	264	294	330	365	405	455	505	555	605	708	828
180	939	291	1252	388	1878	583	-	227	257	287	322	357	397	447	497	547	597	700	820
200	848	263	1130	351	1696	526	-	-	242	272	307	342	382	432	482	532	582	685	805
224	759	235	1013	314	1519	471	-	-	-	253	288	323	363	413	463	513	563	666	786
250	682	211	910	282	1365	423	-	-	-	-	268	303	343	393	443	493	543	645	765
280	611	189	814	252	1222	379	-	-	-	-	-	278	318	368	419	469	519	621	741
315	544	169	726	225	1089	338	-	-	-	-	-	-	289	339	389	440	490	593	713
355	484	150	645	200	968	300	-	-	-	-	-	-	-	-	355	405	456	559	680
400	430	133	574	178	861	267	-	-	-	-	-	-	-	-	-	365	416	520	642
450	383	119	511	158	766	238	-	-	-	-	-	-	-	-	-	-	369	475	598
500	345	107	460	143	691	214	-	-	-	-	-	-	-	-	-	-	-	427	552

VAR 300

Longueur du pas [mm]	Plage de vitesse - entraxes																		
	Gamme de vitesse en tours par minute de la poulie entraînée par une poulie VAR (tr/nm)						Longueur intérieure des courroies en mm												
	750		1000		1500		995	1055	1115	1175	1245	1315	1395	1495	1595	1795	2000	2240	
	Min.	Max.	Min.	Max.	Min.	Max.	Entraxe en mm pour des courroies 54x16												
180	1164	362	1553	483	2339	724	-	-	-	-	280	316	356	407	457	558	658	778	
200	1052	327	1403	436	2105	655	-	-	-	-	266	301	342	392	442	543	643	763	
224	943	293	1258	391	1887	587	-	-	-	-	-	284	324	374	424	525	625	745	
250	848	264	1131	352	1697	528	-	-	-	-	-	-	304	355	405	505	605	725	
280	760	236	1013	315	1520	473	-	-	-	-	-	-	-	331	381	481	581	701	
315	678	210	904	281	1356	421	-	-	-	-	-	-	-	-	354	454	554	674	
355	603	187	804	250	1206	375	-	-	-	-	-	-	-	-	-	421	521	642	
400	536	167	715	222	1073	334	-	-	-	-	-	-	-	-	-	383	484	604	
450	478	148	637	198	956	297	-	-	-	-	-	-	-	-	-	-	440	562	
500	431	134	574	178	862	268	-	-	-	-	-	-	-	-	-	-	394	517	

Poulies Poly-V



Les poulies Poly-V SIT sont conçues et fabriquées avec une grande précision pour garantir une durée de vie optimale et la performance des transmissions.

SIT est capable de fournir une solution personnalisée pour répondre à toutes les applications spéciales.

Pour le montage avec moyeux amovibles SER-SIT®

Matière : acier pour les diamètres jusqu'à 50 mm
fonte grise (GG25) pour les diamètres supérieurs à 50 mm.

Finition : phosphatation au manganèse noir.

Sections:

- J
- K
- L
- M



Exécutions spéciales

Sur demande, SIT est capable de concevoir et fabriquer tout type de poulie selon les exigences du client. Pour une vitesse périphérique supérieure à 33 m / s, il est fortement recommandé d'utiliser l'acier comme matériau de construction.

$$\text{Vitesse périphérique [m/s]} = \frac{\text{diamètre de la poulie [mm]} \cdot \text{tr/min}}{19100}$$

Équilibrage

Les poulies Poly-V SIT ont un degré statiquement équilibré à G6,3 à 1500 tr / min conformément à la norme ISO 1940.

Sur demande, il est possible d'effectuer un équilibrage statique à des degrés supérieurs ou un équilibrage dynamique.

DIMENSIONS DES GORGES ET TOLÉRANCES

Conformément à la norme ISO 9982

Section	α°	P [mm]	Tolérance de ΣP [mm]	r_t min. [mm]	r_b min. [mm]	S min. [mm]	h [mm]
J	$40 \pm 0,5$	$2,34 \pm 0,03$	$\pm 0,03$	0,20	0,40	1,8	1,1
K	$40 \pm 0,5$	$3,56 \pm 0,05$	$\pm 0,03$	0,25	0,50	2,5	1,6
L	$40 \pm 0,5$	$4,70 \pm 0,05$	$\pm 0,03$	0,40	0,40	3,3	2,3
M	$40 \pm 0,5$	$9,40 \pm 0,08$	$\pm 0,03$	0,75	3,30	6,4	2,6

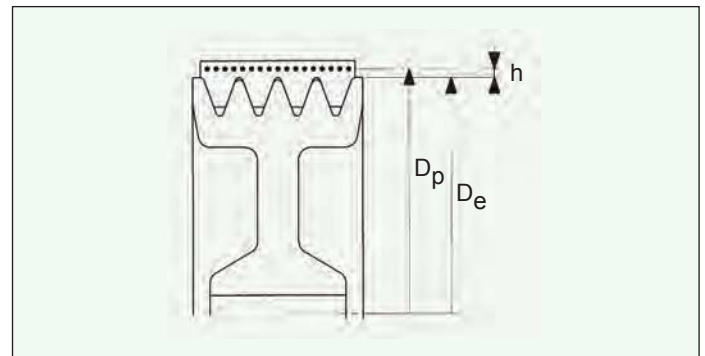
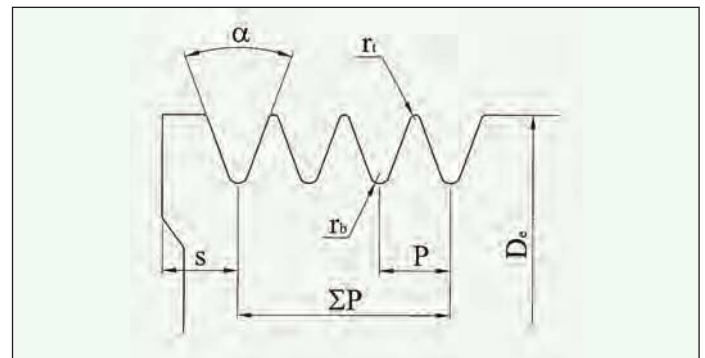

D_e = diamètre externe

D_p = diamètre primitif

$h = (D_p - D_e)/2$

Dimensions des poulies Poly-V - moyeux amovibles SER-SIT®

Les poulies de petit diamètre sont fournies avec un moyeu préalésé. (Réf. Type 1)



“PYB” Poly-V “J”

De [mm]	Nb de gorges	Type	Moyeu amovible SER-SIT®	L [mm]	z [mm]	M [mm]	U [mm]	d [mm]	W [mm]
20	4	1	-	22,5	-	-	-	5,0	13,5
	8	1	-	32,0	-	-	-	5,0	23,0
	12	1	-	41,5	-	-	-	5,0	32,5
	16	1	-	51,0	-	-	-	5,0	42,0
	20	1	-	61,0	-	-	-	5,0	52,0
25	4	1	-	22,5	-	-	-	5,0	13,5
	8	1	-	32,0	-	-	-	5,0	23,0
	12	1	-	41,5	-	-	-	5,0	32,5
	16	1	-	51,0	-	-	-	5,0	42,0
	20	1	-	61,0	-	-	-	5,0	52,0
30	4	1	-	22,5	-	-	-	9,5	13,5
	8	1	-	32,0	-	-	-	9,5	23,0
	12	1	-	41,5	-	-	-	9,5	32,5
	16	1	-	51,0	-	-	-	9,5	42,0
	20	1	-	61,0	-	-	-	9,5	52,0
35	4	1	-	22,5	-	-	-	9,5	13,5
	8	1	-	32,0	-	-	-	9,5	23,0
	12	1	-	41,5	-	-	-	9,5	32,5
	16	1	-	51,0	-	-	-	9,5	42,0
	20	1	-	61,0	-	-	-	9,5	52,0
40	4	1	-	22,5	-	-	-	12,0	13,5
	8	1	-	32,0	-	-	-	12,0	23,0
	12	1	-	41,5	-	-	-	12,0	32,5
	16	1	-	51,0	-	-	-	12,0	42,0
	20	1	-	61,0	-	-	-	12,0	52,0
45	4	1	-	22,5	-	-	-	12,0	13,5
	8	1	-	32,0	-	-	-	12,0	23,0
	12	1	-	41,5	-	-	-	12,0	32,5
	16	1	-	51,0	-	-	-	12,0	42,0
	20	1	-	61,0	-	-	-	12,0	52,0
50	4	1	-	22,5	-	-	-	12,0	13,5
	8	1	-	32,0	-	-	-	12,0	23,0
	12	1	-	41,5	-	-	-	12,0	32,5
	16	1	-	51,0	-	-	-	12,0	42,0
	20	1	-	61,0	-	-	-	12,0	52,0
56	4	7	1108	23,0	9,5	50	-	-	13,5
	8	3	1108	23,0	-	-	-	-	23,0
	12	1	-	41,5	-	-	-	12,0	32,5
	16	1	-	51,0	-	-	-	12,0	42,0
	20	1	-	61,0	-	-	-	12,0	52,0
60	4	7	1108	23,0	9,5	50	-	-	13,5
	8	3	1108	23,0	-	-	-	-	23,0
	12	2	1108	23,0	9,5	-	45	-	32,5
	16	1	-	51,0	-	-	-	12,0	42,0
	20	1	-	61,0	-	-	-	12,0	52,0
63	4	7	1108	23,0	9,5	50	-	-	13,5
	8	3	1108	23,0	-	-	-	-	23,0
	12	2	1108	23,0	9,5	-	45	-	32,5
	16	1	-	51,0	-	-	-	12,0	42,0
	20	1	-	61,0	-	-	-	12,0	52,0
67	4	7	1108	23,0	9,5	50	-	-	13,5
	8	3	1108	23,0	-	-	-	-	23,0
	12	2	1108	23,0	9,5	-	51	-	32,5
	16	1	-	51,0	-	-	-	12,0	42,0
	20	1	-	61,0	-	-	-	12,0	52,0

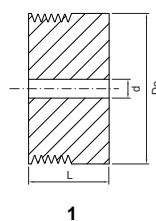

1

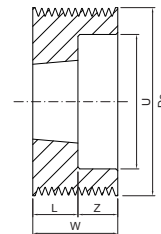

2

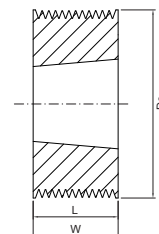

3

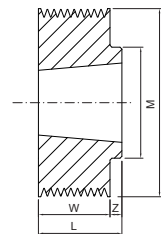

7

Désignation

PYB 200 J 8

Poulie Poly-V pour moyeux amovibles

Diamètre externe in mm

Profil

Nombre de gorge

Dimensions des poulies Poly-V - moyeux amovibles SER-SIT®



» "PYB" Poly-V "J"

De [mm]	Nb de gorges	Type	Moyeu amovible SER-SIT®	L [mm]	z [mm]	M [mm]	U [mm]	d [mm]
71	4	7	1108	23	9,5	60	-	13,5
	8	3	1108	23	-	-	-	23,0
	12	2	1108	23	9,5	-	55	32,5
	16	3	1215	42	-	-	55	42,0
	20	2	1215	42	10,0	-	55	52,0
75	4	7	1108	23	9,5	60	-	13,5
	8	3	1108	23	-	-	-	23,0
	12	2	1210	26	6,5	-	59	32,5
	16	2	1610	26	16,0	-	59	42,0
	20	2	1615	42	10,0	-	59	52,0
80	4	7	1310	26	12,5	70	-	13,5
	8	7	1310	26	3,0	70	-	23,0
	12	2	1610	26	6,5	-	64	32,5
	16	2	1610	26	16,0	-	64	42,0
	20	2	1615	42	10,0	-	64	52,0
85	4	7	1310	26	12,5	70	-	13,5
	8	7	1310	26	3,0	70	-	23,0
	12	2	1610	26	6,5	-	69	32,5
	16	2	1610	26	16,0	-	69	42,0
	20	2	1615	42	10,0	-	69	52,0
90	4	7	1610	26	12,5	82	-	13,5
	8	7	1610	26	3,0	82	-	23,0
	12	2	1610	26	6,5	-	74	32,5
	16	2	1610	26	16,0	-	74	42,0
	20	2	1615	42	10,0	-	74	52,0
95	4	7	1610	26	12,5	82	-	13,5
	8	7	1610	26	3,0	82	-	23,0
	12	2	1610	26	6,5	-	79	32,5
	16	2	1610	26	16,0	-	79	42,0
	20	2	1615	42	10,0	-	79	52,0
100	4	7	1610	26	12,5	82	-	13,5
	8	7	1610	26	3,0	82	-	23,0
	12	2	1610	26	6,5	-	82	32,5
	16	2	1610	26	16,0	-	82	42,0
	20	2	1615	42	10,0	-	82	52,0
106	4	7	1610	26	12,5	88	-	13,5
	8	7	1610	26	3,0	88	-	23,0
	12	2	1610	26	6,5	-	88	32,5
	16	2	1610	26	16,0	-	88	42,0
	20	2	1615	42	10,0	-	88	52,0
112	4	7	1610	26	12,5	90	-	13,5
	8	7	1610	26	3,0	90	-	23,0
	12	2	1610	26	6,5	-	94	32,5
	16	2	1610	26	16,0	-	94	42,0
	20	2	1615	42	10,0	-	94	52,0
118	4	7	1610	26	12,5	90	-	13,5
	8	7	1610	26	3,0	90	-	23,0
	12	2	2012	32	0,5	-	98	32,5
	16	2	2012	32	10,0	-	98	42,0
	20	2	2012	32	20,0	-	98	52,0
125	4	8	1610	26	12,5	90	109	13,5
	8	8	1610	26	3,0	90	109	23,0
	12	2	2012	32	0,5	-	105	32,5
	16	2	2012	32	10,0	-	105	42,0
	20	2	2517	45	7,0	-	105	52,0

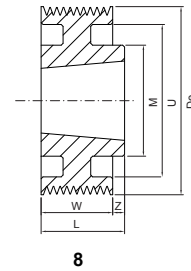
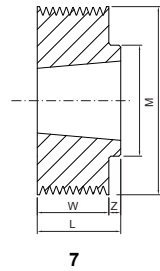
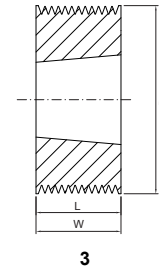
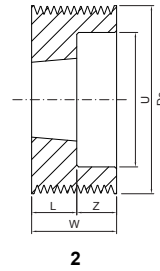

Dimensions des poulies Poly-V - moyeux amovibles SER-SIT®



» "PYB" Poly-V "J"

De [mm]	Nb de gorges	Type	Moyeu amovible SER-SIT®	L [mm]	z [mm]	M [mm]	U [mm]	d [mm]
132	4	8	1610	26	12,5	90	116	13,5
	8	8	1610	26	3,0	90	116	23,0
	12	2	2012	32	0,5	-	112	32,5
	16	2	2012	32	10,0	-	112	42,0
	20	2	2517	45	7,0	-	112	52,0
140	4	8	1610	26	12,5	90	124	13,5
	8	8	1610	26	3,0	90	124	23,0
	12	7	2517	45	12,5	120	-	32,5
	16	7	2517	45	3,0	120	-	42,0
	20	2	2517	45	7,0	-	124	52,0
160	4	8	2012	32	18,5	110	144	13,5
	8	8	2012	32	9,0	110	144	23,0
	12	8	2517	45	12,5	120	140	32,5
	16	8	2517	45	3,0	120	140	42,0
	20	2	2517	45	7,0	-	140	52,0
180	4	6	2012	32	9,3	110	164	13,5
	8	6	2012	32	4,5	110	164	23,0
	12	6	2517	45	6,3	120	160	32,5
	16	6	2517	45	1,5	120	160	42,0
	20	5	2517	45	3,5	120	160	52,0
200	4	6	2012	32	9,3	110	185	13,5
	8	6	2012	32	4,5	110	185	23,0
	12	6	2517	45	6,3	120	180	32,5
	16	6	2517	45	1,5	120	180	42,0
	20	5	2517	45	3,5	120	180	52,0
224	4	6	2012	32	9,3	110	208	13,5
	8	6	2012	32	4,5	110	208	23,0
	12	6	2517	45	6,3	120	204	32,5
	16	6	2517	45	1,5	120	204	42,0
	20	5	2517	45	3,5	120	204	52,0
250	4	9	2012	32	9,3	110	234	13,5
	8	9	2012	32	4,5	110	234	23,0
	12	6	2517	45	6,3	120	230	32,5
	16	6	2517	45	1,5	120	230	42,0
	20	5	2517	45	3,5	120	230	52,0
280	4	9	2012	32	9,3	110	264	13,5
	8	9	2012	32	4,5	110	264	23,0
	12	9	2517	45	6,3	120	260	32,5
	16	9	2517	45	1,5	120	260	42,0
	20	10	2517	45	3,5	120	260	52,0
315	4	9	2012	32	9,3	110	299	13,5
	8	9	2012	32	4,5	110	299	23,0
	12	9	2517	45	6,3	120	295	32,5
	16	9	2517	45	1,5	120	295	42,0
	20	10	2517	45	3,5	120	295	52,0
355	4	9	2517	45	15,7	120	339	13,5
	8	9	2517	45	11,0	120	339	23,0
	12	9	2517	45	6,3	120	335	32,5
	16	9	3020	52	5,0	146	335	42,0
	20	10	3020	52	-	146	335	52,0
400	4	9	2517	45	15,8	120	380	13,5
	8	9	2517	45	11,0	120	380	23,0
	12	9	2517	45	6,3	120	380	32,5
	16	9	3020	52	5,0	146	380	42,0
	20	10	3020	52	-	146	380	52,0

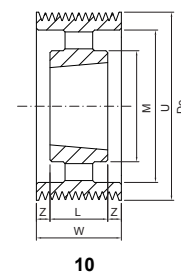
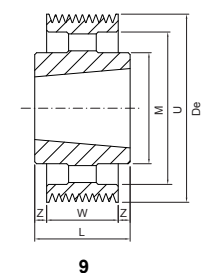
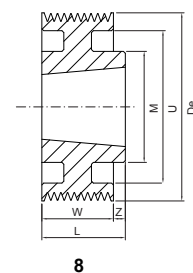
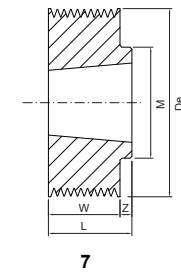
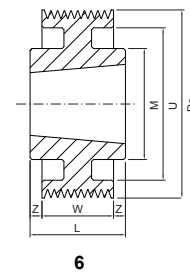
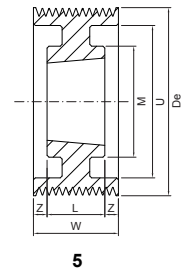
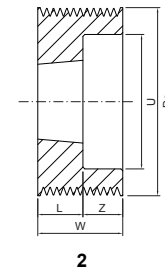

Dimensions des poulies Poly-V - moyeux amovibles SER-SIT®



“PYB” Poly-V “K”

De [mm]	Nb de gorges	Type	Moyeu amovible SER-SIT®	L [mm]	z [mm]	M [mm]	U [mm]	d [mm]	W [mm]
50	4	1	-	32	-	-	-	12	20,5
	6	1	-	40	-	-	-	12	28,5
	8	1	-	48	-	-	-	12	36,0
	10	1	-	54	-	-	-	12	42,0
	12	1	-	61	-	-	-	12	49,0
56	4	3	1108	20,5	-	-	-	-	20,5
	6	1	-	40	-	-	-	12	28,5
	8	1	-	48	-	-	-	12	36,0
	10	1	-	54	-	-	-	12	42,0
	12	1	-	61	-	-	-	12	49,0
60	4	3	1108	20,5	-	-	-	-	20,5
	6	2	1108	22	6,5	-	45	-	28,5
	8	1	-	48	-	-	-	12	36,0
	10	1	-	54	-	-	-	12	42,0
	12	1	-	61	-	-	-	12	49,0
63	4	3	1108	20,5	-	-	-	-	20,5
	6	2	1108	22	6,5	-	48	-	28,5
	8	1	-	48	-	-	-	12	36,0
	10	1	-	54	-	-	-	12	42,0
	12	1	-	61	-	-	-	12	49,0
67	4	3	1108	20,5	-	-	-	-	20,5
	6	2	1108	22	6,5	-	51	-	28,5
	8	1	-	48	-	-	-	12	36,0
	10	1	-	54	-	-	-	12	42,0
	12	1	-	61	-	-	-	12	49,0
71	4	3	1108	20,5	-	-	-	-	20,5
	6	2	1108	23	6,5	-	55	-	28,5
	8	2	1210	26	10	-	55	-	36,0
	10	3	1215	42	-	-	-	-	42,0
	12	2	1215	42	7	-	55	-	49,0
75	4	3	1108	20,5	-	-	-	-	20,5
	6	2	1210	26	2,5	-	59	-	28,5
	8	2	1210	26	10	-	59	-	36,0
	10	3	1215	42	-	-	-	-	42,0
	12	2	1215	42	7	-	59	-	49,0
80	4	7	1210	26	5,5	70	-	-	20,5
	6	2	1210	26	2,5	-	64	-	28,5
	8	2	1210	26	10	-	64	-	36,0
	10	3	1215	42	-	-	-	-	42,0
	12	2	1215	42	7	-	64	-	49,0
85	4	7	1210	26	5,5	70	-	-	20,5
	6	2	1210	26	2,5	-	69	-	28,5
	8	2	1210	26	10	-	69	-	36,0
	10	3	1215	42	-	-	-	-	42,0
	12	2	1215	42	7	-	69	-	49,0
90	4	7	1210	26	5,5	82	-	-	20,5
	6	2	1210	26	2,5	-	74	-	28,5
	8	2	1210	26	10	-	74	-	36,0
	10	3	1215	42	-	-	-	-	42,0
	12	2	1215	42	7	-	74	-	49,0
95	4	7	1610	26	5,5	90	-	-	20,5
	6	2	1610	26	2,5	-	79	-	28,5
	8	2	1610	26	10	-	79	-	36,0
	10	3	1615	42	-	-	-	-	42,0
	12	2	1615	42	7	-	79	-	49,0
100	4	7	1610	26	5,5	90	-	-	20,5
	6	2	1610	26	2,5	-	82	-	28,5
	8	2	1610	26	10	-	82	-	36,0
	10	3	1615	42	-	-	-	-	42,0
	12	2	1615	42	7	-	82	-	49,0

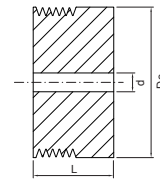

1

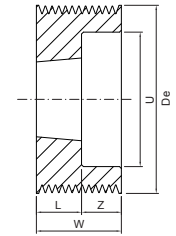

2

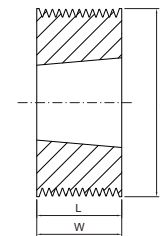

3

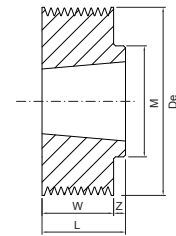

7

Dimensions des poulies Poly-V - moyeux amovibles SER-SIT®



» "PYB" Poly-V "K"

De [mm]	Nb de gorges	Type	Moyeu amovible SER-SIT®	L [mm]	z [mm]	M [mm]	U [mm]	d [mm]
106	4	7	1610	26	5,5	90	-	20,5
	6	2	1610	26	2,5	-	88	28,5
	8	2	1610	26	10	-	88	36,0
	10	3	1615	42	-	-	-	42,0
	12	2	1615	42	7	-	88	49,0
112	4	7	1610	26	5,5	90	-	20,5
	6	2	1610	26	2,5	-	94	28,5
	8	2	1610	26	10	-	94	36,0
	10	3	1615	42	-	-	-	42,0
	12	2	1615	42	7	-	94	49,0
118	4	7	1610	26	5,5	90	-	20,5
	6	7	2012	32	3,5	110	-	28,5
	8	2	2012	32	4	-	98	36,0
	10	2	2012	32	10	-	98	42,0
	12	2	2012	32	17	-	98	49,0
125	4	8	1610	26	5,5	90	109	20,5
	6	7	2012	32	3,5	110	-	28,5
	8	2	2012	32	4	-	105	36,0
	10	2	2012	32	10	-	105	42,0
	12	2	2517	45	4	-	105	49,0
132	4	8	1610	26	5,5	90	116	20,5
	6	7	2012	32	3,5	110	-	28,5
	8	2	2012	32	4	-	112	36,0
	10	2	2012	32	10	-	112	42,0
	12	2	2517	45	4	-	112	49,0
140	4	8	1610	26	5,5	90	124	20,5
	6	7	2517	45	16,5	120	-	28,5
	8	7	2517	45	9	120	-	36,0
	10	7	2517	45	3	120	-	42,0
	12	2	2517	45	4	-	124	49,0
150	4	8	1610	26	5,5	90	134	20,5
	6	7	2517	45	16,5	120	-	28,5
	8	7	2517	45	9	120	-	36,0
	10	7	2517	45	3	120	-	42,0
	12	2	2517	45	4	-	130	49,0
160	4	8	2012	32	11,5	110	144	20,5
	6	8	2517	45	16,5	120	140	28,5
	8	8	2517	45	9	120	140	36,0
	10	8	2517	45	3	120	140	42,0
	12	2	2517	45	4	-	140	49,0
170	4	8	2012	32	11,5	110	154	20,5
	6	8	2517	45	16,5	120	150	28,5
	8	8	2517	45	9	120	150	36,0
	10	7	2517	45	3	120	150	42,0
	12	2	2517	45	4	-	150	49,0
180	4	6	2012	32	5,75	110	164	20,5
	6	6	2517	45	8,25	120	160	28,5
	8	6	2517	45	4,5	120	160	36,0
	10	6	2517	45	1,5	120	160	42,0
	12	5	2517	45	2	120	160	49,0
190	4	6	2012	32	5,75	110	174	20,5
	6	6	2517	45	8,25	120	170	28,5
	8	6	2517	45	4,5	120	170	36,0
	10	6	2517	45	1,5	120	170	42,0
	12	5	2517	45	2	120	170	49,0
200	4	6	2012	32	5,75	110	184	20,5
	6	6	2517	45	8,25	120	180	28,5
	8	6	2517	45	4,5	120	180	36,0
	10	6	2517	45	1,5	120	180	42,0
	12	5	2517	45	2	120	180	49,0

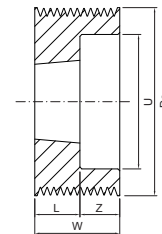

2

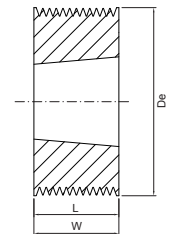

3

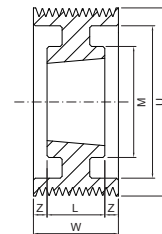

5

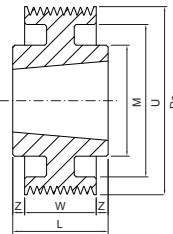

6

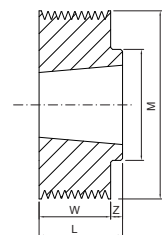

7

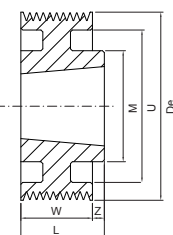

8

Dimensions des poulies Poly-V - moyeux amovibles SER-SIT®



» "PYB" Poly-V "K"

De [mm]	Nb de gorges	Type	Moyeu amovible SER-SIT®	L [mm]	z [mm]	M [mm]	U [mm]	d [mm]
212	4	6	2012	32	5,75	110	196	20,5
	6	6	2517	45	8,25	120	192	28,5
	8	6	2517	45	4,5	120	192	36,0
	10	6	2517	45	1,5	120	192	42,0
	12	5	2517	45	2	120	192	49,0
224	4	6	2012	32	5,75	110	208	20,5
	6	6	2517	45	8,25	120	204	28,5
	8	6	2517	45	4,5	120	204	36,0
	10	6	2517	45	1,5	120	204	42,0
	12	5	2517	45	2	120	204	49,0
236	4	6	2012	32	5,75	110	220	20,5
	6	6	2517	45	8,25	120	216	28,5
	8	6	2517	45	4,5	120	216	36,0
	10	6	2517	45	1,5	120	216	42,0
	12	5	2517	45	2	120	216	49,0
250	4	9	2012	32	5,75	110	234	20,5
	6	6	2517	45	8,25	120	230	28,5
	8	6	2517	45	4,5	120	230	36,0
	10	6	2517	45	1,5	120	230	42,0
	12	5	2517	45	2	120	230	49,0
280	4	9	2012	32	5,75	110	264	20,5
	6	9	2517	45	8,25	120	260	28,5
	8	9	2517	45	4,5	120	260	36,0
	10	9	3020	52	5	146	256	42,0
	12	9	3020	52	1,5	146	256	49,0
315	4	9	2012	32	5,75	110	299	20,5
	6	9	2517	45	8,25	120	295	28,5
	8	9	2517	45	4,5	120	295	36,0
	10	6	3020	52	5	146	285	42,0
	12	9	3020	52	1,5	146	285	49,0
355	4	9	2517	45	12,25	120	339	20,5
	6	9	2517	45	8,25	120	339	28,5
	8	9	3020	52	8	146	335	36,0
	10	9	3020	52	5	146	335	42,0
	12	9	3020	52	1,5	146	335	49,0
400	4	9	2517	45	2,25	120	380	20,5
	6	9	2517	45	8,25	120	380	28,5
	8	9	3020	52	8	146	370	36,0
	10	9	3020	52	5	146	370	42,0
	12	9	3020	52	1,5	146	370	49,0
450	4	9	2517	45	12,25	120	420	20,5
	6	9	2517	45	8,25	120	420	28,5
	8	9	3020	52	8	146	420	36,0
	10	9	3020	52	5	146	420	42,0
	12	9	3020	52	1,5	146	420	49,0
500	4	9	2517	45	12,25	120	470	20,5
	6	9	2517	45	8,25	120	470	28,5
	8	9	3020	52	8	146	470	36,0
	10	9	3020	52	5	146	470	42,0
	12	9	3020	52	1,5	146	470	49,0

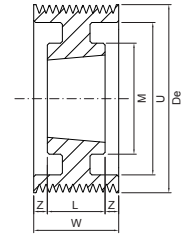

5

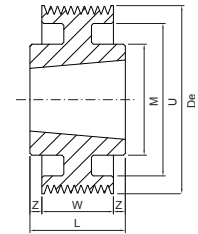

6

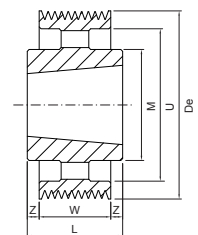

9

Dimensions des poulies Poly-V - moyeux amovibles SER-SIT®



“PYB” Poly-V “L”

De [mm]	Nb de gorges	Type	Moyeu amovible SER-SIT®	L [mm]	z [mm]	M [mm]	U [mm]
75	6	2	1210	26	12,5	56	38,5
	8	2	1210	26	22	56	48,0
	10	2	1215	42	15	56	57,0
	12	2	1215	42	25	56	67,0
80	6	2	1210	26	12,5	56	38,5
	8	2	1210	26	22	56	48,0
	10	2	1215	42	15	56	57,0
	12	2	1215	42	25	56	67,0
85	6	2	1210	26	12,5	61	38,5
	8	2	1210	26	22	61	48,0
	10	2	1215	42	15	61	57,0
	12	2	1215	42	25	61	67,0
	16	4	1215	42	22	61	86,0
90	6	2	1210	26	12,5	66	38,5
	8	2	1210	26	22	66	48,0
	10	2	1215	42	15	66	57,0
	12	2	1215	42	25	66	67,0
	16	4	1215	42	22	66	86,0
95	6	2	1210	26	12,5	71	38,5
	8	2	1210	26	22	71	48,0
	10	2	1215	42	15	71	57,0
	12	2	1215	42	25	71	67,0
	16	4	1215	42	22	71	86,0
100	6	2	1610	26	12,5	76	38,5
	8	2	1610	26	22	76	48,0
	10	2	2012	32	25	79	57,0
	12	2	2012	32	35	79	67,0
	16	4	2012	32	27	79	86,0
106	6	2	1610	26	12,5	82	38,5
	8	2	1610	26	22	82	48,0
	10	2	2012	32	25	82	57,0
	12	2	2012	32	35	82	67,0
	16	4	2012	32	27	82	86,0
112	6	2	1610	26	12,5	88	38,5
	8	2	1610	26	22	88	48,0
	10	2	2012	32	25	88	57,0
	12	2	2012	32	35	88	67,0
	16	4	2012	32	27	88	86,0
118	6	2	2012	32	6,5	94	38,5
	8	2	2012	32	16	94	48,0
	10	4	2517	45	6	97	57,0
	12	4	2517	45	11	97	67,0
	16	4	2517	45	20,5	97	86,0
	20	4	2517	45	30	97	105,0
125	6	2	2012	32	6,5	101	38,5
	8	2	2012	32	16	101	48,0
	10	4	2517	45	6	101	57,0
	12	4	2517	45	11	101	67,0
	16	4	2517	45	20,5	101	86,0
	20	4	2517	45	30	101	105,0
132	6	2	2012	32	6,5	108	38,5
	8	2	2012	32	16	108	48,0
	10	4	2517	45	6	108	57,0
	12	4	2517	45	11	108	67,0
	16	4	2517	45	20,5	108	86,0
	20	4	2517	45	30	108	105,0

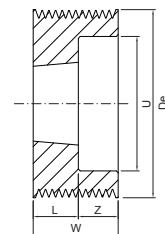

2

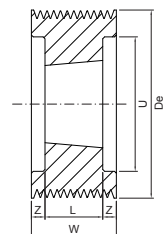

4

Dimensions des poulies Poly-V - moyeux amovibles SER-SIT®



» "PYB" Poly-V "L"

De [mm]	Nb de gorges	Type	Moyeu amovible SER-SIT®	L [mm]	z [mm]	M [mm]	U [mm]	d [mm]
140	6	7	2517	45	6,5	120	-	38,5
	8	2	2517	45	3	-	116	48,0
	10	4	2517	45	6	-	116	57,0
	12	4	2517	45	11	-	116	67,0
	16	4	2517	45	20,5	-	116	86,0
	20	4	3020	52	26,5	-	116	105,0
150	6	7	2517	45	6,5	120	-	38,5
	8	2	2517	45	3	-	126	48,0
	10	4	2517	45	6	-	126	57,0
	12	4	2517	45	11	-	126	67,0
	16	4	2517	45	20,5	-	126	86,0
	20	4	3020	52	26,5	-	126	105,0
160	6	7	2517	45	6,5	120	-	38,5
	8	2	2517	45	3	-	136	48,0
	10	4	2517	45	6	-	136	57,0
	12	4	2517	45	11	-	136	67,0
	16	4	3020	52	17	-	136	86,0
	20	4	3020	52	26,5	-	136	105,0
170	6	8	2517	45	6,5	120	146	38,5
	8	2	2517	45	3	-	146	48,0
	10	4	2517	45	6	-	146	57,0
	12	4	2517	45	11	-	146	67,0
	16	4	3020	52	17	-	146	86,0
	20	4	3020	52	26,5	-	146	105,0
180	6	6	2517	45	3,25	120	156	38,5
	8	5	2517	45	1,5	120	156	48,0
	10	5	2517	45	6	120	156	57,0
	12	5	2517	45	11	120	156	67,0
	16	4	3020	52	17	-	156	86,0
	20	4	3020	52	26,5	-	156	105,0
190	6	6	2517	45	3,25	120	166	38,5
	8	5	2517	45	1,5	120	166	48,0
	10	5	2517	45	6	120	166	57,0
	12	5	2517	45	11	120	166	67,0
	16	5	3020	52	17	146	166	86,0
	20	5	3020	52	26,5	146	166	105,0
200	6	6	2517	45	3,25	120	176	38,5
	8	5	2517	45	1,5	120	176	48,0
	10	5	3020	52	2,5	146	176	57,0
	12	5	3020	52	7,5	146	176	67,0
	16	5	3020	52	17	146	176	86,0
	20	4	3535	89	8	-	176	105,0
212	6	6	2517	45	3,25	120	188	38,5
	8	5	2517	45	1,5	120	188	48,0
	10	5	3020	52	2,5	146	188	57,0
	12	5	3020	52	7,5	146	188	67,0
	16	5	3020	52	17	146	188	86,0
	20	4	3535	89	8	-	188	105,0
224	6	6	2517	45	3,25	120	202	38,5
	8	5	2517	45	1,5	120	202	48,0
	10	5	3020	52	2,5	146	202	57,0
	12	5	3020	52	7,5	146	202	67,0
	16	5	3020	52	17	146	202	86,0
	20	5	3535	89	8	178	202	105,0
236	6	6	2517	45	3,25	120	214	38,5
	8	5	2517	45	1,5	120	214	48,0
	10	5	3020	52	2,5	146	214	57,0
	12	5	3020	52	7,5	146	214	67,0
	16	5	3020	52	17	146	214	86,0
	20	5	3535	89	8	178	214	105,0

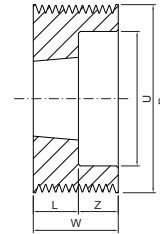

2

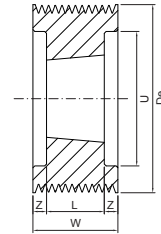

4

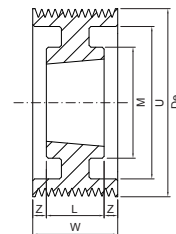

5

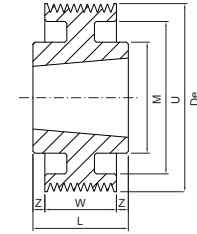

6

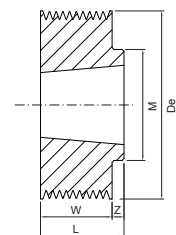

7

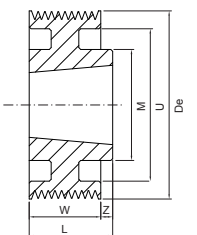

8

Dimensions des poulies Poly-V - moyeux amovibles SER-SIT®



» "PYB" Poly-V "L"

De [mm]	Nb de gorges	Type	Moyeu amovible SER-SIT®	L [mm]	z [mm]	M [mm]	U [mm]	d [mm]
250	6	9	2517	45	3,25	120	228	38,5
	8	5	2517	45	1,5	120	228	48,0
	10	5	3020	52	2,5	146	228	57,0
	12	5	3020	52	7,5	146	228	67,0
	16	5	3020	52	17	146	228	86,0
	20	5	3535	89	8	178	226	105,0
280	6	6	2517	45	3,25	120	256	38,5
	8	6	3020	52	2	146	256	48,0
	10	5	3020	52	2,5	146	256	57,0
	12	5	3020	52	7,5	146	256	67,0
	16	6	3535	89	1,5	178	256	86,0
	20	5	3535	89	8	178	256	105,0
315	6	9	2517	45	3,25	120	285	38,5
	8	9	3020	52	2	146	285	48,0
	10	6	3535	89	16	178	285	57,0
	12	6	3535	89	11	178	285	67,0
	16	6	3535	89	1,5	178	285	86,0
	20	5	4040	102	1,5	215	285	105,0
355	6	9	3020	52	6,75	146	325	38,5
	8	9	3020	52	2	146	325	48,0
	10	9	3535	89	16	178	325	57,0
	12	9	3535	89	11	178	325	67,0
	16	9	3535	89	1,5	178	325	86,0
	20	5	4040	102	1,5	215	325	105,0
400	6	9	3020	52	6,75	146	370	38,5
	8	9	3020	52	2	146	370	48,0
	10	9	3535	89	16	178	370	57,0
	12	9	3535	89	11	178	370	67,0
	16	9	3535	89	1,5	178	370	86,0
	20	10	4040	102	1,5	215	370	105,0
450	6	9	3020	52	6,75	146	420	38,5
	8	9	3020	52	2	146	420	48,0
	10	9	3535	89	16	178	420	57,0
	12	9	3535	89	11	178	420	67,0
	16	9	3535	89	1,5	178	420	86,0
	20	9	4040	102	1,5	215	420	105,0
500	6	9	3020	52	6,75	146	470	38,5
	8	9	3020	52	2	146	470	48,0
	10	9	3535	89	16	178	470	57,0
	12	9	3535	89	11	178	470	67,0
	16	9	3535	89	1,5	178	470	86,0
	20	9	5050	127	11	267	470	105,0
630	6	9	3020	52	6,75	146	600	38,5
	8	9	3020	52	2	146	600	48,0
	10	9	3535	89	16	178	600	57,0
	12	9	3535	89	11	178	600	67,0
	16	9	4040	102	8	215	600	86,0
	20	9	5050	127	11	267	600	105,0
800	6	9	3535	89	25,2	178	770	38,5
	8	9	3535	89	20,5	178	770	48,0
	10	9	4040	102	22,5	215	770	57,0
	12	9	4040	102	17,5	215	770	67,0
	16	9	5050	127	20,5	267	770	86,0
	20	9	5050	127	11	267	770	105,0

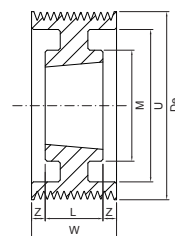

5

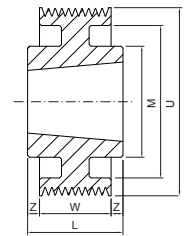

6

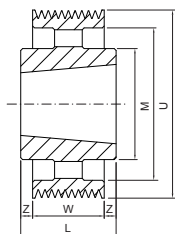

9

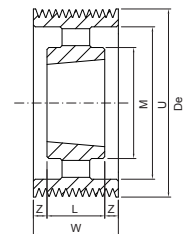

10

Accessoires



Description

Les moyeux amovibles SER-SIT® sont conçus pour :

- un assemblage parfait
- un démontage rapide de la poulie et des entraînements
- une facilité d'emploi, sans outil, sauf une clé Allen.

La large gamme d'alésages finis disponibles garantit un montage immédiat, ce qui permet d'éviter les coûteux temps d'arrêt de l'usine.

Les moyeux sont usinés avec des rainures de clavettes aux normes UNI et DIN. Celles-ci sont en plus des vis de serrage qui, dans de nombreux cas, sont suffisantes pour satisfaire le couple requis. La fixation par les moyeux SER-SIT® permet d'éliminer tout déglacement entre le moyeu et l'alésage de manière à éliminer positivement la fretting corrosion. Les moyeux SER-SIT® sont interchangeables avec tous les types similaires vendus à travers le monde.



Rainures de clavette UNI 6604-69 / DIN 6885

Diamètre des alésages [mm]	b [mm]	t ₂ [mm]	Diamètre des alésages [pouces]	b [pouces]	t ₂ [pouces]
9 ÷ 10	3	1,4	3/8 - 1/2	1/8	1/16
11 ÷ 12	4	1,8	9/16 - 3/4	3/16	3/32
13 ÷ 17	5	2,3	13/16 - 1	1/4	1/8
18 ÷ 22	6	2,8	1-1/16 - 1-1/4	5/16	1/8
23 ÷ 30	8	3,3	1-5/16	3/8	1/8
31 ÷ 38	10	3,3	1-5/8 - 1-3/4	7/16	5/32
39 ÷ 44	12	3,3	1-7/8 - 2	1/2	5/32
45 ÷ 50	14	3,8	2-1/8 - 2-1/2	5/8	7/32
51 ÷ 58	16	4,3	2-5/8 - 3	3/4	1/4
59 ÷ 65	18	4,4	3-1/8 - 3-1/2	7/8	5/16
66 ÷ 75	20	4,9	3-3/4 - 4	1	3/8
76 ÷ 85	22	5,4	4-1/4 ÷ 5	1-1/4	7/16
86 ÷ 95	25	5,4			
96 ÷ 110	28	6,4			
111 ÷ 130	32	7,4			

Clavette réduite seulement pour les cas du tableau ci-dessous.

Diamètre des alésages [mm]	Type des moyeux d'assemblage SER-SIT®	b [mm]	t ₂ [mm]
24 - 25	1008	8	1,3
28	1108	8	1,3
35	1310	10	1,3
42	1615	12	2,2
65	2517	18	3,3
Diamètre des alésages [pouces]	Type des moyeux d'assemblage SER-SIT®	b [pouces]	t ₂ [pouces]
1	1008	1/4	1/16
1-1/8	1108	5/16	5/64
1-5/8 - 1-3/4	1615	7/16	1/8
3-1/2	3535	7/8	1/4
3-3/4 - 4	4040	1	1/4

Caractéristiques techniques des moyeux amovibles SER-SIT®

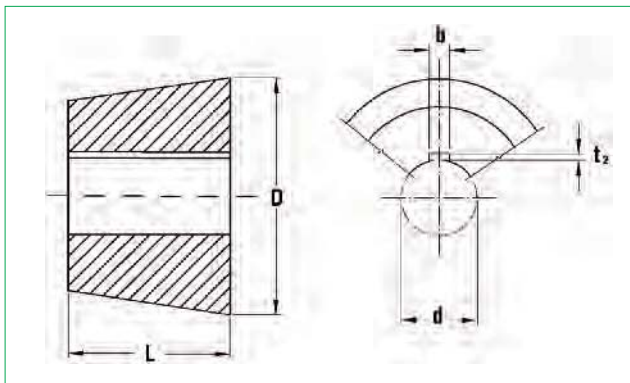

Désignation

BC 4025 F20

Moyeu amovible SER-SIT®

Type

Diamètre de l'alésage [mm]

Type des moyeux amovibles SER-SIT®	Diamètre des alésages d	L [mm]	D [mm]	vis				M _S [Nm]
				N°	Filetage	Longueur [mm]	clé Allen [mm]	
1008 (25.20)	mm pou- 11 12 14 15 16 18 19 20 22 24* 25* 3/8 1/2 5/8 3/4 7/8 1*	22,3	35	2	1/4	13	3	5,5
1108 (28.20)	mm pou- 11 12 14 15 16 17 18 19 20 22 24 25 26 27 28* 3/8 1/2 5/8 3/4 7/8 1 1 1/8*	22,3	38	2	1/4	13	3	5,5
1210 (30.25)	mm pou- 11 12 14 15 16 18 19 20 22 24 25 26 28 30 32 1/2 5/8 3/4 7/8 1 1 1/8 1 1/4	25,4	47	2	3/8	16	5	20
1215 (30.40)	mm pou- 12 14 15 16 18 19 20 22 24 25 26 28 30 32 1/2 5/8 3/4 7/8 1 1 1/8 1 1/4	38,1	47	2	3/8	16	5	20
1310 (35.25)	mm pou- 14 16 18 19 20 22 24 25 28 30 32 35* 1/2 5/8 3/4 7/8 1 1 1/8 1 1/4 1 3/8	25,4	52	2	3/8	16	5	20
1610 (40.25)	mm pou- 12 14 15 16 18 19 20 22 24 25 26 28 30 32 35 38 40 42 3/8 1/2 5/8 3/4 7/8 1 1 1/8 1 1/4 1 3/8 1 1/2 1 5/8	25,4	57	2	3/8	16	5	20
1615 (40.40)	mm pou- 12 14 15 16 18 19 20 22 24 25 26 28 30 32 35 38 40 42* 1/2 5/8 3/4 7/8 1 1 1/8 1 1/4 1 3/8 1 1/2 1 5/8* 1 3/4*	38,1	57	2	3/8	16	5	20
2012 (50.30)	mm pou- 14 15 16 18 19 20 22 24 25 26 28 30 32 35 38 40 42 45 48 50 5/8 3/4 7/8 1 1 1/8 1 1/4 1 3/8 1 1/2 1 5/8 1 3/4 1 7/8 2	31,8	70	2	7/16	22	5	30
2517 (65.45)	mm pou- 18 19 20 22 24 25 28 30 32 35 38 40 42 45 48 50 55 60 65* 3/4 7/8 1 1 1/8 1 1/4 1 3/8 1 1/2 1 5/8 1 3/4 1 7/8 2 2 1/8 2 1/4 2 3/8 2 1/2	44,5	85	2	1/2	25	6	50
3020 (75.50)	mm pou- 22 25 28 30 32 35 38 40 42 45 48 50 55 57 60 65 70 75 1 1/4 1 3/8 1 1/2 1 5/8 1 3/4 1 7/8 2 2 1/8 2 1/4 2 3/8 2 1/2 2 5/8 2 3/4 2 7/8 3	50,8	108	2	5/8	32	8	90
3030 (75.75)	mm pou- 25 28 30 32 35 38 40 42 45 47 48 50 55 60 65 70 75 1 1/4 1 3/8 1 1/2 1 5/8 1 3/4 1 7/8 2 2 1/8 2 1/4 2 3/8 2 1/2 2 5/8 2 3/4 2 7/8 3	76,2	108	2	5/8	32	8	90
3535 (90.90)	mm pou- 25 35 38 40 42 45 48 50 55 60 65 70 75 80 85 90 1 1/2 1 5/8 1 3/4 1 7/8 2 2 1/8 2 1/4 2 3/8 2 1/2 2 5/8 2 3/4 2 7/8 3 3 1/8 3 1/4 3 3/8 3 1/2*	88,9	127	3	1/2	38	10	115
4040 (100.100)	mm pou- 40 42 45 50 55 60 65 70 75 80 85 90 95 100 1 3/4 2 2 3/4 3 1/2 3 3/4* 4*	101,6	146	3	5/8	44	14	170
4545 (115.115)	mm pou- 55 60 65 70 75 80 85 90 95 100 105 110 3 3 1/2 4	114,3	162	3	3/4	51	14	195
5050 (125.125)	mm pou- 50 60 65 70 75 80 85 90 95 100 110 115 120 125 3 1/2 4	127,0	178	3	7/8	57	17	275
6050** (150.125)	mm pou- 80-85-90-95-100-105-110-115-120-125-130-135-140-145-150	127,0	235	3	1-1/4	107	48	650

Moyeu amovible dont le diamètre d'alésage est en **gras** sont en acier et non en fonte

M_S = Couple de serrage des vis

* = rainure de clavette réduite

** = Tête de vis hexagonale

Montage des moyeux amovibles SER-SIT®

- Avant d'installer le moyeu sur la poulie, nettoyez soigneusement l'alésage et les pièces.
- Installez le dans la poulie en veillant à ce que les demi-alésages filetés de la poulie coïncident avec les alésages non filetés du moyeu d'alésage.
- Serrez à la main, la vis.
- Monter la poulie sur l'arbre après l'avoir soigneusement nettoyée.

Mettre en position et serrer les vis alternativement.

- Démontage: déposer les vis et desserrer la clavette jusqu'à ce que le moyeu soit relâché.

Note

Veillez à ce que le haut clavette ne soit pas en contact avec le fond de son logement dans le moyeu- vérifier qu'il subsiste un jeu.

Moyeux amovibles SER-SIT® : couples de glissement et charges axiales admissibles

Les couples de glissement ont été calculés en tenant compte du couple de serrage nominal pour la vis (Ms), d'une valeur de coefficient de frottement $\eta = 0,14$ et dans un assemblage sans clavette.

Type des moyeux amovibles SER-SIT®	Diamètre de l'alésage d [mm]	Couple de glissement [Nm]	Charge axiale admissible [N]
1008	12	29	3990
	19	51	4940
	24	66	5490
1108	12	28	-
	19	49	4630
	24	64	5220
	28	79	5720
1210 + 1215	16	82	8840
	19	105	9800
	24	142	10900
	32	210	12300
1610 + 1615	19	98	-
	24	135	9570
	38	240	11900
	42	265	12700
2012	24	165	11500
	38	310	14400
	42	340	15700
	48	400	-
	50	420	16700
2517	24	220	-
	38	380	17000
	42	430	18500
	48	510	-
	55	600	21000
	60	670	22300
3020 + 3030	38	520	23900
	48	730	26100
	55	890	29900
	60	970	31500
	75	1300	34500
3535	42	1000	41000
	60	1580	49800
	75	2150	54800
	90	2600	59000
4040	48	1700	-
	60	2300	70200
	75	3150	77200
	100	4400	89400
4545	55	2500	79600
	75	3900	93000
	100	5500	107700
	110	6300	-
5050	75	3950	91800
	100	5650	106600
	125	7370	119500

SERLOCK® est le nouveau moyeu de serrage, sans clavette, breveté pour une utilisation immédiate avec toutes les transmissions de puissance adaptés aux moyeux SER-SIT®, T / L ou similaires :

- Interchangeable directement avec les moyeux SER-SIT® ou T / L
- Disponible en types 1108, 1210, 1610, 2012, 2517, 3020
- Avec diamètre d'alésage de 12 à 70 mm selon les types
- Permet des réglages axiaux et angulaires très fins

SERLOCK® est un système de serrage innovant qui combine tous les avantages des moyeux sans friction SIT-LOCK® avec la grande disponibilité d'une large gamme de composants PT pour les moyeux :

- Poulies trapézoïdales et Poly-V
- Poulies de synchronisation
- Accouplements
- Pignons

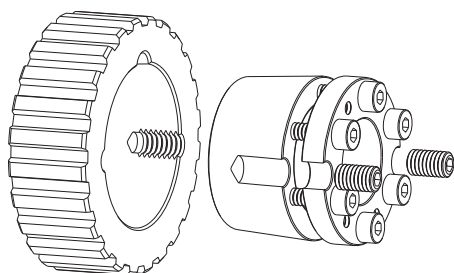

SERLOCK® élimine :

- Tous les problèmes liés aux systèmes conventionnels de clavette (jeu, rupture, corrosion par frettage, démontage difficile, positionnement axiale et angulaire restreint du composant sur l'arbre);
- Usinage supplémentaire sur le composant à fixer sur l'arbre, requis lors de l'utilisation de moyeux/éléments de serrage conventionnels.

Avec les avantages suivants:

- Disponibilité immédiate du système (élément à serrer + système de serrage avancé);
- Assemblage et démontage faciles;
- Possibilité de réduire le diamètre des arbres utilisés jusqu'à 25%;
- Ajustements angulaire et axial facile des composants par rapport à l'arbre;
- Possibilité d'utiliser SERLOCK® également sur des arbres avec rainure de clavette.

Tout cela signifie des avantages immédiats pour l'utilisateur en raison de l'augmentation potentielle de la productivité.

L'assemblage est extrêmement simple et rapide

- 1) Assembler le moyeu SERLOCK® sur l'arbre au moyen de la vis à deux positions;
- 2) Positionner la partie dans la position axiale et angulaire requise;

- 3) Serrer progressivement la vis de réglage jusqu'à ce que le couple Ms, indiqué dans les tableaux techniques, soit atteint;
- 4) Serrer la vis de serrage graduellement et uniformément comme sur le croquis, jusqu'à ce que le couple Ms, indiqué dans les tableaux techniques, soit atteint.

NOTE:

Ne lubrifiez pas ni le moyeu SERLOCK®, ni l'arbre sur lequel il est monté.

Pour démonter :

- 1) Démontez les vis de serrage;
- 2) Insérer les vis dans les trous de démontage filetés, les serrer jusqu'à ce que la douille conique soit relâchée;

Afin d'enlever la bague extérieure, si nécessaire :

- 3) Après avoir retiré la douille intérieure, desserrer l'ensemble de vis;
- 4) En gardant l'ensemble desserré en place, positionnez la douille intérieure à 30 ° par rapport à la position d'origine;
- 5) Insérez les vis et serrez-les progressivement jusqu'à ce que la bague intérieure soit relâchée.

Désignation	SL 1108 F10
SL: SERLOCK®	
Type	
F... diamètre de l'alésage (mm)	

Dimensions et performances des types standards



Dans le cas d'applications spécifiques, d'alésages, types différents ou d'arbres creux, veuillez prendre contact avec notre service technique.

La tolérance d'arbre est h8 ou mieux, si elle n'est pas spécifiée autrement, et les dimensions sont exprimées en mm.

SERLOCK® 1108																
Type	Dimensions [mm]					Performances		Vis				Vis de serrage				
	d	H	H1	H2	D	M _T [Nm]	F _{ax} [N]	N°	Type	M _s	clé Allen	N°	Type	M _s	clé Allen	
SL1108F12	12	20	29,5	33,5	39	109	18200	6	M4	4,9	3	2	1/4 W	4,9	3	
SL1108F14	14	20	29,5	33,5	39	128	18200	6	M4	4,9	3	2	1/4 W	4,9	3	
SL1108F15	15	20	29,5	33,5	39	137	18200	6	M4	4,9	3	2	1/4 W	4,9	3	
SL1108F16	16	20	29,5	33,5	39	146	18200	6	M4	4,9	3	2	1/4 W	4,9	3	
SL1108F18	18	20	29,5	33,5	39	164	18200	6	M4	4,9	3	2	1/4 W	4,9	3	
SL1108F19	19	20	29,5	33,5	39	173	18200	6	M4	4,9	3	2	1/4 W	4,9	3	
SL1108F20	20	20	29,5	33,5	39	182	18200	6	M4	4,9	3	2	1/4 W	4,9	3	
SL1108F22	22	20	29,5	33,5	39	201	18200	6	M4	4,9	3	2	1/4 W	4,9	3	

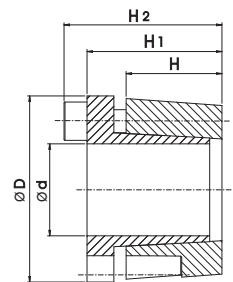

SERLOCK® 1210																
Type	Dimensions [mm]					Performances		Vis				Vis de serrage				
	d	H	H1	H2	D	M _T [Nm]	F _{ax} [N]	N°	Type	M _s	clé Allen	N°	Type	M _s	clé Allen	
SL1210F14	14	25	37,5	43,5	49	246	35100	6	M6	14	5	2	3/8 W	14	5	
SL1210F15	15	25	37,5	43,5	49	263	35100	6	M6	14	5	2	3/8 W	14	5	
SL1210F16	16	25	37,5	43,5	49	281	35100	6	M6	14	5	2	3/8 W	14	5	
SL1210F18	18	25	37,5	43,5	49	316	35100	6	M6	14	5	2	3/8 W	14	5	
SL1210F19	19	25	37,5	43,5	49	333	35100	6	M6	14	5	2	3/8 W	14	5	
SL1210F20	20	25	37,5	43,5	49	351	35100	6	M6	14	5	2	3/8 W	14	5	
SL1210F22	22	25	37,5	43,5	49	386	35100	6	M6	14	5	2	3/8 W	14	5	
SL1210F24	24	25	37,5	43,5	49	421	35100	6	M6	14	5	2	3/8 W	14	5	
SL1210F25	25	25	37,5	43,5	49	438	35100	6	M6	14	5	2	3/8 W	14	5	

SERLOCK® 1610																
Type	Dimensions [mm]					Performances		Vis				Vis de serrage				
	d	H	H1	H2	D	M _T [Nm]	F _{ax} [N]	N°	Type	M _s	clé Allen	N°	Type	M _s	clé Allen	
SL1610F14	14	25	37,5	43,5	59	246	35100	6	M6	14	5	2	3/8 W	14	5	
SL1610F15	15	25	37,5	43,5	59	263	35100	6	M6	14	5	2	3/8 W	14	5	
SL1610F16	16	25	37,5	43,5	59	281	35100	6	M6	14	5	2	3/8 W	14	5	
SL1610F18	18	25	37,5	43,5	59	316	35100	6	M6	14	5	2	3/8 W	14	5	
SL1610F19	19	25	37,5	43,5	59	333	35100	6	M6	14	5	2	3/8 W	14	5	
SL1610F20	20	25	37,5	43,5	59	351	35100	6	M6	14	5	2	3/8 W	14	5	
SL1610F22	22	25	37,5	43,5	59	386	35100	6	M6	14	5	2	3/8 W	14	5	
SL1610F24	24	25	37,5	43,5	59	421	35100	6	M6	14	5	2	3/8 W	14	5	
SL1610F25	25	25	37,5	43,5	59	438	35100	6	M6	14	5	2	3/8 W	14	5	
SL1610F26	26	25	37,5	43,5	59	456	35100	6	M6	14	5	2	3/8 W	14	5	
SL1610F28	28	25	37,5	43,5	59	491	35100	6	M6	14	5	2	3/8 W	14	5	
SL1610F30	30	25	37,5	43,5	59	526	35100	6	M6	14	5	2	3/8 W	14	5	
SL1610F32	32	25	37,5	43,5	59	561	35100	6	M6	14	5	2	3/8 W	14	5	
SL1610F35	35	25	34,8	40,8	59	614	35100	6	M6	14	5	2	3/8 W	14	5	

M _T	Moment de couple transmissible	Nm
M _S	Couple de serrage des vis	Nm
F _{ax}	Charge axiale transmissible	N



SERLOCK® 2012															
Type	Dimensions [mm]					Performances		Vis				Vis de serrage			
	d	H	H1	H2	D	M _T [Nm]	F _{ax} [N]	N°	Type	M _s	clé Allen	N°	Type	M _s	clé Allen
SL2012F19	19	30	45,5	53,5	71	436	45900	6	M8	25	6	2	7/16 W	25	6
SL2012F20	20	30	45,5	53,5	71	459	45900	6	M8	25	6	2	7/16 W	25	6
SL2012F22	22	30	45,5	53,5	71	505	45900	6	M8	25	6	2	7/16 W	25	6
SL2012F24	24	30	45,5	53,5	71	551	45900	6	M8	25	6	2	7/16 W	25	6
SL2012F25	25	30	45,5	53,5	71	574	45900	6	M8	25	6	2	7/16 W	25	6
SL2012F26	26	30	45,5	53,5	71	597	45900	6	M8	25	6	2	7/16 W	25	6
SL2012F28	28	30	45,5	53,5	71	643	45900	6	M8	25	6	2	7/16 W	25	6
SL2012F30	30	30	45,5	53,5	71	689	45900	6	M8	25	6	2	7/16 W	25	6
SL2012F32	32	30	45,5	53,5	71	735	45900	6	M8	25	6	2	7/16 W	25	6
SL2012F35	35	30	45,5	53,5	71	804	45900	6	M8	25	6	2	7/16 W	25	6
SL2012F38	38	30	45,5	53,5	71	873	45900	6	M8	25	6	2	7/16 W	25	6
SL2012F40	40	30	45,5	53,5	71	919	45900	6	M8	25	6	2	7/16 W	25	6
SL2012F42	42	30	45,5	53,5	71	965	45900	6	M8	25	6	2	7/16 W	25	6

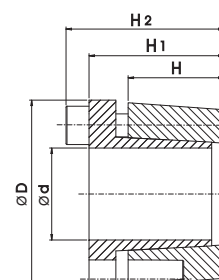

SERLOCK® 2517															
Type	Dimensions [mm]					Performances		Vis				Vis de serrage			
	d	H	H1	H2	D	M _T [Nm]	F _{ax} [N]	N°	Type	M _s	clé Allen	N°	Type	M _s	clé Allen
SL2517F24	24	45	60,5	68,5	86	551	45900	6	M8	25	6	2	1/2 W	35	6
SL2517F25	25	45	60,5	68,5	86	574	45900	6	M8	25	6	2	1/2 W	35	6
SL2517F26	26	45	60,5	68,5	86	597	45900	6	M8	25	6	2	1/2 W	35	6
SL2517F28	28	45	60,5	68,5	86	643	45900	6	M8	25	6	2	1/2 W	35	6
SL2517F30	30	45	60,5	68,5	86	689	45900	6	M8	25	6	2	1/2 W	35	6
SL2517F 32	32	45	60,5	68,5	86	735	45900	6	M8	25	6	2	1/2 W	35	6
SL2517F35	35	45	60,5	68,5	86	804	45900	6	M8	25	6	2	1/2 W	35	6
SL2517F38	38	45	60,5	68,5	86	873	45900	6	M8	25	6	2	1/2 W	35	6
SL2517F40	40	45	60,5	68,5	86	919	45900	6	M8	25	6	2	1/2 W	35	6
SL2517F42	42	45	60,5	68,5	86	965	45900	6	M8	25	6	2	1/2 W	35	6
SL2517F45	45	45	60,5	68,5	86	1034	45900	6	M8	25	6	2	1/2 W	35	6
SL2517F48	48	45	60,5	68,5	86	1103	45900	6	M8	25	6	2	1/2 W	35	6
SL2517F50	50	45	60,5	68,5	86	1148	45900	6	M8	25	6	2	1/2 W	35	6
SL2517F55	55	45	60,5	68,5	86	1263	45900	6	M8	25	6	2	1/2 W	35	6

SERLOCK® 3020															
Type	Dimensions [mm]					Performances		Vis				Vis de serrage			
	d	H	H1	H2	D	M _T [Nm]	F _{ax} [N]	N°	Type	M _s	clé Allen	N°	Type	M _s	clé Allen
SL3020F30	30	50	68,5	78,5	108	993	66200	6	M10	49	8	2	5/8 W	65	8
SL3020F32	32	50	68,5	78,5	108	1059	66200	6	M10	49	8	2	5/8 W	65	8
SL3020F35	35	50	68,5	78,5	108	1159	66200	6	M10	49	8	2	5/8 W	65	8
SL3020F38	38	50	68,5	78,5	108	1258	66200	6	M10	49	8	2	5/8 W	65	8
SL3020F40	40	50	68,5	78,5	108	1324	66200	6	M10	49	8	2	5/8 W	65	8
SL3020F42	42	50	68,5	78,5	108	1391	66200	6	M10	49	8	2	5/8 W	65	8
SL3020F45	45	50	68,5	78,5	108	1490	66200	6	M10	49	8	2	5/8 W	65	8
SL3020F48	48	50	68,5	78,5	108	1589	66200	6	M10	49	8	2	5/8 W	65	8
SL3020F50	50	50	68,5	78,5	108	1655	66200	6	M10	49	8	2	5/8 W	65	8
SL3020F55	55	50	68,5	78,5	108	1821	66200	6	M10	49	8	2	5/8 W	65	8
SL3020F60	60	50	68,5	78,5	108	1986	66200	6	M10	49	8	2	5/8 W	65	8
SL3020F65	65	50	68,5	78,5	108	2152	66200	6	M10	49	8	2	5/8 W	65	8
SL3020F70	70	50	68,5	78,5	108	2318	66200	6	M10	49	8	2	5/8 W	65	8

M_T Moment de couple transmissible Nm
 M_S Couple de serrage des vis Nm
 F_{ax} Charge axiale transmissible N

Glissières moteur

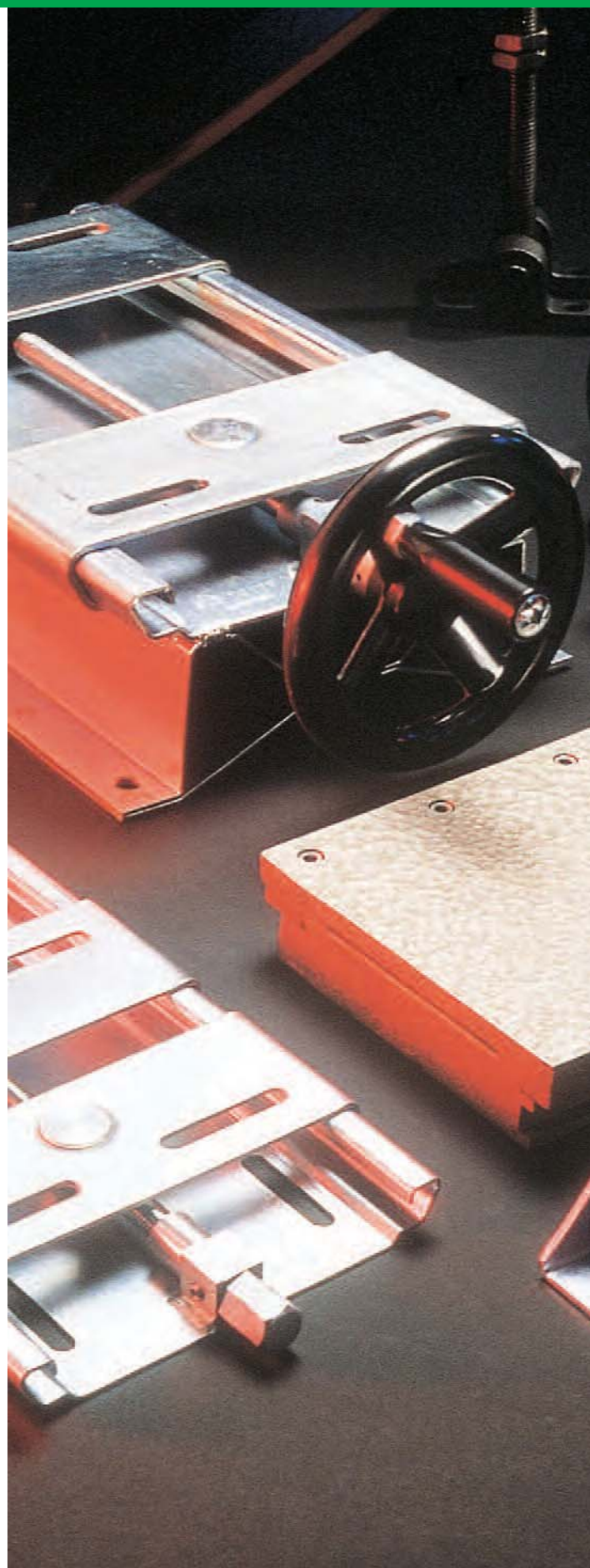

GLISSIERES MOTEUR COMPATTA - TC

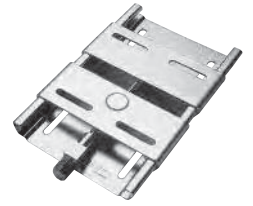

Description

La glissière moteur COMPATTA est très facile à installer, de faible hauteur elle convient à tout type de moteur.

Le réglage de la glissière moteur s'effectue par clé sans déplacer les boulons du moteur et ainsi sans compromettre l'alignement du variateur.

La glissière moteur a été conçue pour permettre de larges plages de réglage.

Les six modèles décrits ci-dessous sont disponibles en stock. Cette série de glissières moteur est en acier galvanisé, d'autres matériaux comme l'acier inoxydable sont disponibles sur demande.

SIT est capable de fabriquer des glissières moteur personnalisées conformément aux exigences du client.

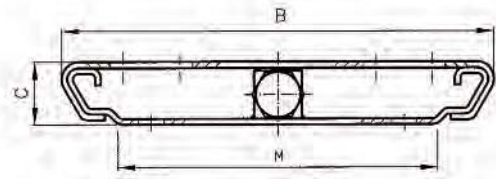
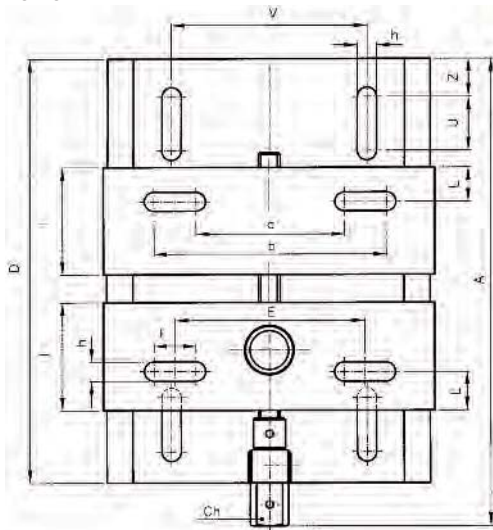

Désignation	TC	MEDIA
Embase moteur Compatta TC		
Type		

Type de glissière	Type du moteur	56M	63M	71M	80M	90S	90L	100L	112M	132S	132M	160M	160L	180M	180L	200L	225S	225M
TC 80 (mignon)	Ajustement max [mm]	98	88	76	63	-	-	-	-	-	-	-	-	-	-	-	-	-
TC 90 (piccola)		-	-	118	105	90	90	-	-	-	-	-	-	-	-	-	-	-
TC 112 (junior)		-	-	-	169	154	154	134	105	-	-	-	-	-	-	-	-	-
TC 132 (media)		-	-	-	-	208	208	188	158	132	132	-	-	-	-	-	-	-
TC 180 (maxi)		-	-	-	-	-	-	-	-	-	-	176	176	151	151	-	-	-
TC 225 (magnum)		-	-	-	-	-	-	-	-	-	-	-	-	-	-	182	144	144

Type de glissière	Type du moteur électrique	Puissance du moteur électrique 2 pôles (2.800 tr/min) [kW]	Puissance du moteur électrique 4 pôles (1.400 tr/min) [kW]	A [mm]	B [mm]	C [mm]	D [mm]	E [mm]	F [mm]	I [mm]	L [mm]	M [mm]	Ch [mm]	V [mm]	Z [mm]	U [mm]	a x b x h [mm]	Poids [kg]
TC 80 (mignon)	56+80	0,12-1,1	0,1-0,75	240	154	22	220	85	25	50	16	113	15	90	25	40	60x110x9	1,5
TC 90 (piccola)	71+90	0,37-2,2	0,25-1,5	293	180	25	270	90	45	70	20	134	16	110	25	40	45x135x9	2,0
TC 112 (junior)	80+112	0,75-4	0,55-4	365	220	30	340	110	43,5	85	23	163	17	130	25	50	66,5x153,5x13	3,5
TC 132 (media)	90+132	1,5-9	1,1-7,5	430	250	35	400	134	47,5	100	26	185	22	150	25	60	86,5x181,5x13	5,8
TC 180 (maxi)	160+180	15-25	11-22	532	380	40	500	220	60	125	35	305	24	260	25	60	160x280x15	12,0
TC 225 (magnum)	200+225	30-45	30-45	635	448	50	600	280	55	160	50	338	27	300	30	70	225x335x18	22,5

GLISSIERES MOTEUR VAREX - TX

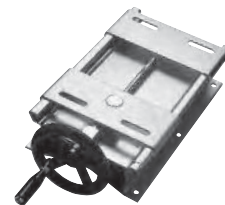

Description

Les glissières moteur VAREX (en acier galvanisé) sont une solution économique et optimale dans les systèmes à vitesse variable, avec une poulie à vitesse variable dans lesquels le déplacement axial du

moteur électrique permet une variation de vitesse en continu de l'arbre entraîné.

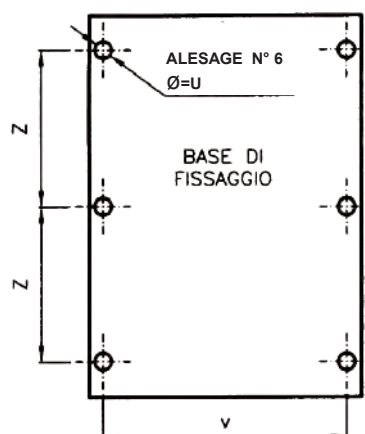
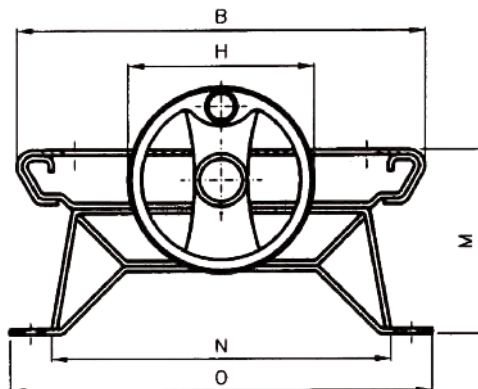
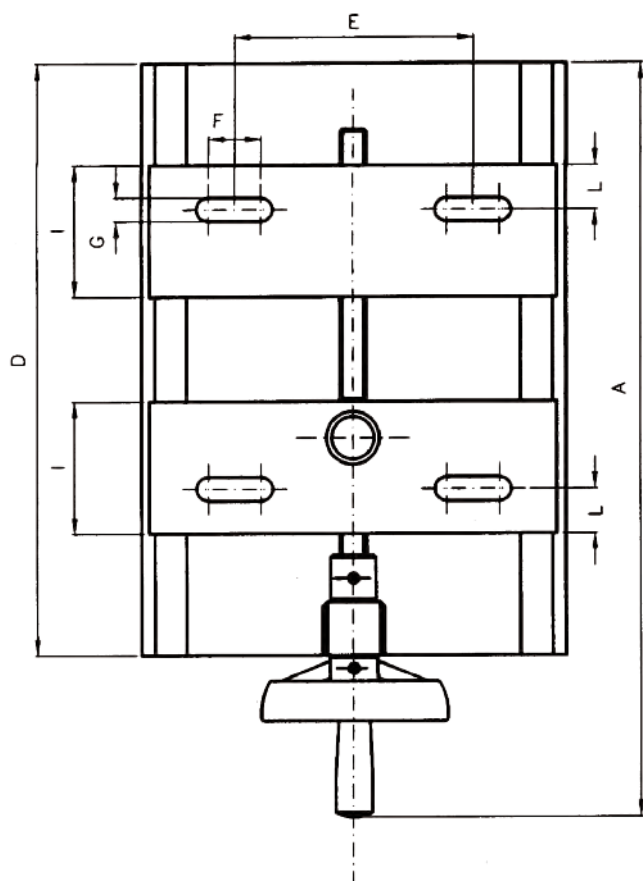

Type de glissière	Type de moteur	56M	63M	71M	80M	90S	90L	100L	112M	132S	132M
TX (mignon)	Ajustement max [mm]	98	88	76	63	-	-	-	-	-	-
TX (piccola)		-	-	118	105	90	90	-	-	-	-
TX (media)		-	-	-	-	208	208	188	158	132	132

Désignation **TX MEDIA**

Base de moteur Varex TX

Type

Type de glissière moteur	Type de moteur électrique	Puissance du moteur électrique 2 pôles (2.800 tr/min) [kW]	Puissance du moteur électrique 4 pôles (1.400 tr/min) [kW]	A [mm]	B [mm]	D [mm]	E [mm]	F [mm]	G [mm]	H [mm]	I [mm]	L [mm]	M [mm]	N [mm]	O [mm]	U [mm]	V [mm]	Z [mm]	Poids [kg]
TX (mignon)	55-80	0,12-1,1	0,1-0,75	323	158	220	85	25	9	100	50	16	73	116	160	8,5	134	95	2,8
TX (piccola)	71-90	0,37-2,2	0,25-1,5	394	182	270	90	45	9	120	70	20	90	140	184	8,5	164	110	4,0
TX (media)	90-132	1,5-9	1,1-7,5	545	250	400	134	47	13	156	100	26	110	192	248	10,5	220	180	10,0

GLISSIERES MOTEUR LINEA - TT



Description

Cette nouvelle gamme de glissières universelles "LINEA" (en acier, protection par zingage) permet la fixation et le réglage de tous les types de moteurs électriques en toutes positions. La conception particulièrement robuste des glissières ainsi que des éléments de fixation permet toutes les combinaisons par le déplacement à la position voulue des poussoirs de réglage filetés.

La mise en place des moteurs électriques est facilitée par un nombre réduit de pièces normalisées et par le maintien des boulons de fixation dans les glissières. Les glissières peuvent être fixées sur leur supports soit à l'aide de boulons ou par soudure électrique, s'il s'agit de supports en acier.

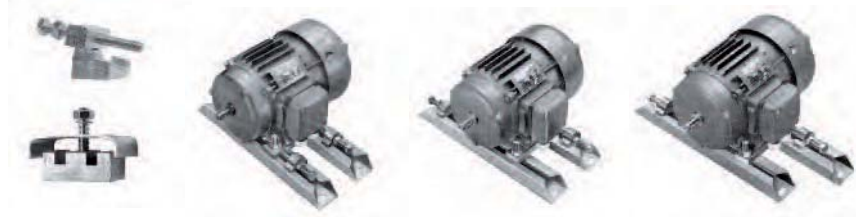

Désignation	TT 100/10
Glissières moteur TT: Linea	
Type	

- ① Moteur
- ② Rail
- ③ Butée poussoir coulissant
- ④ Butée de fixation du moteur
- ⑤ Plaque de fixation

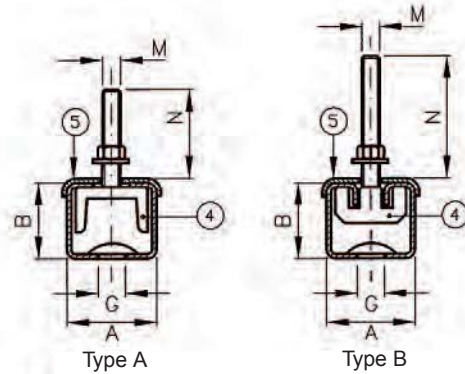
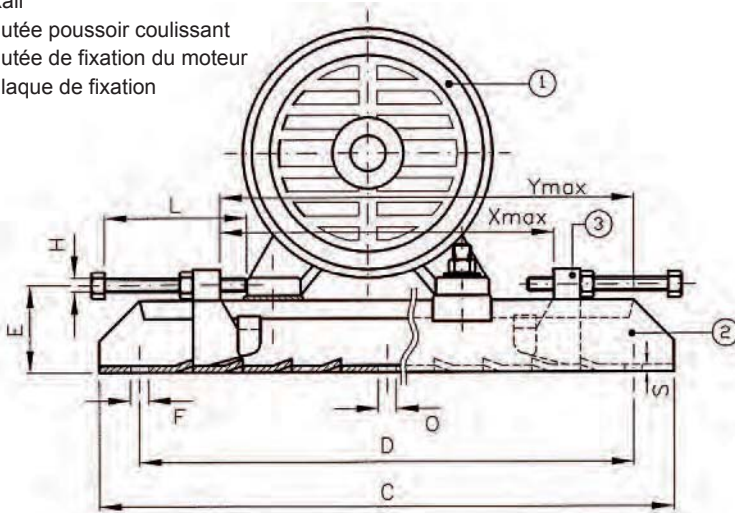

Type	Type de glissière	Moteur	A [mm]	B [mm]	C [mm]	D [mm]	E [mm]	F [mm]	G [mm]	H [mm]	L [mm]	M [mm]	N [mm]	X max. [mm]	Y max. [mm]	S [mm]	Poids [kg]
Type A	TT71/6	56-71	47	31	312	280	38	13	18	M8	80	M6	25	180	220	2,5	2,4
	TT80/8	80	47	31	375	343	38	13	18	M8	80	M8	30	240	280	2,5	2,7
	TT90/8	80-90	59	36	395	355	45	13	21	M10	100	M8	35	245	300	3	4,3
	TT100/10	100	59	36	395	355	45	13	21	M10	100	M10	40	245	300	3	4,4
	TT112/10	100-112	59	36	495	455	45	13	21	M10	100	M10	40	345	400	3	5,2
Type B	TT132/10	100-132	65	40	530	480	52	17	26	M12	120	M10	45	360	420	3,5	7,8
	TT160/12	160	65	40	630	580	52	17	26	M12	120	M12	50	460	520	3,5	8,8
	TT180/12	160-180	75	42	700	630	57	17	26	M12	120	M12	50	520	580	4	12,0
	TT225/16	200-225	82	50	864	800	68	17	27	M16	140	M16	65	670	740	5	20,4
	TT280/20	250-280	116	70	1072	1000	90	20	27	M18	150	M20	80	870	940	6	43,0
	TT355/24	315-355	116	70	1330	1250	90	24	27	M18	150	M24	100	1130	1200	6	52,0
	TT400/30	400	116	70	1430	1350	90	24	30	M18	150	M30	100	1230	1300	6	58,0

GLISSIERES MOTEUR TV 909



Description

Les glissières "TV 909" sont essentiellement conçues pour effectuer de la variation de vitesse par le déplacement axial de moteurs électriques équipés de poulies variables à deux flasques mobiles. La rigidité de ces glissières ainsi que la possibilité de réglage fin à l'aide du système vis-écrou commandé par un volant de manoeuvre permet de résoudre des applications dans lesquelles la vitesse de l'organe mené doit être réglée avec précision.

Le coulissement est assuré par deux glissières à queue d'aronde largement dimensionnées qui assurent un déplacement très souple et sans à coups de l'ensemble menant. Pour effectuer la fixation de la glissière il suffit de faire coulisser le plateau supérieur dans chaque sens afin de découvrir les trous de fixation situés à chaque extrémité

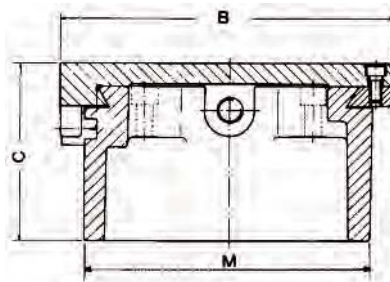
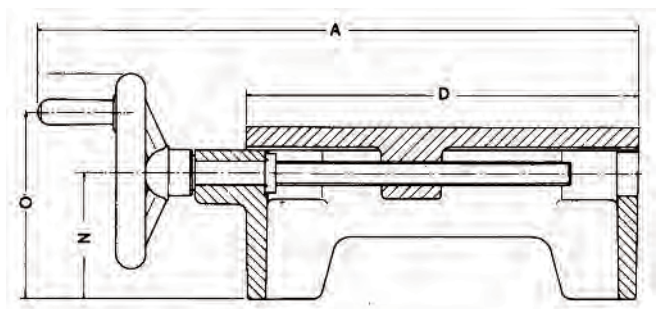
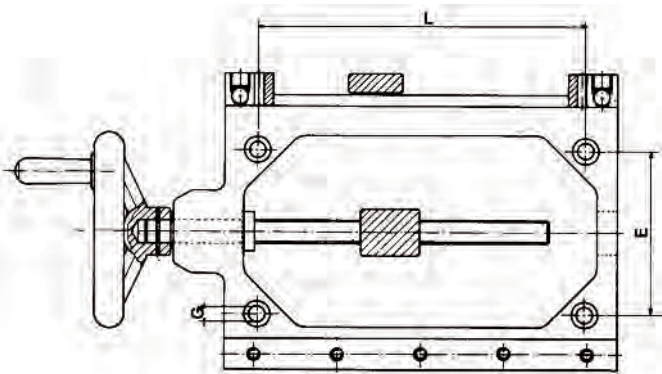

Désignation	TV909	G2
Glissières moteur TV909		
Type		

Type de glissière	A [mm]	B [mm]	C [mm]	D [mm]	E [mm]	G [mm]	L [mm]	M [mm]	N [mm]	O [mm]	Ajustement maximum [mm]	Poids [kg]
TV909 G1	332	163	87	201	85	8,0	163	135	62	97	98	6,7
TV909 G2	400	217	114	254	118	10,5	211	189	83	128	158	13,6
TV909 G3	568	293	128	354	180	13,0	303	258	96	151	217	24,5

GLISSIÈRES MOTEUR TV 910



Description

Les glissières moteur TV910, en fonte, ont les mêmes caractéristiques techniques du modèle 909 mais ont été conçues avec une épaisseur réduite, afin de répondre à des impératifs d'encombrement.

De ce fait le volant de réglage est monté en bout d'un support coudé et la liaison entre son axe et le système vis-écrou est réalisée par un joint de cardan qui assure une transmission sans jeu.

Le volant de réglage se trouve ainsi au dessus du plan de pose ce qui permet à ces glissières d'être utilisées dans des montages dont les limites d'encombrement rendent très difficile l'utilisation d'un tel mécanisme.

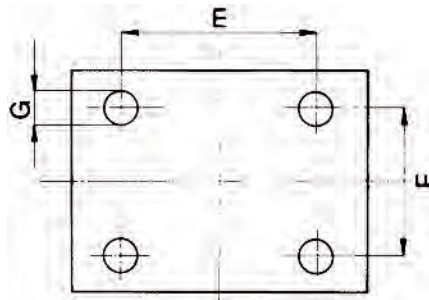

Désignation	TV910	G2
Glissières moteur TV910		
Type		

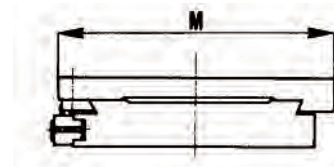
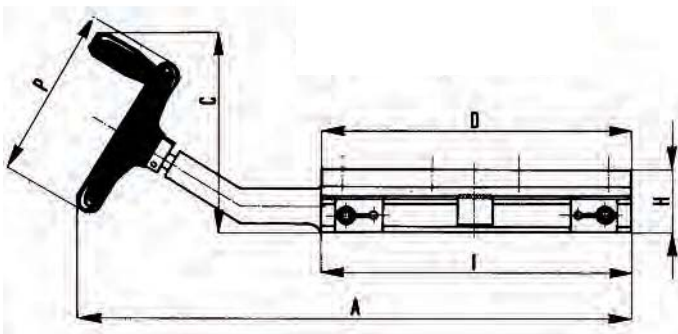

Type de glissière	A [mm]	C [mm]	D [mm]	E [mm]	F [mm]	G [mm]	H [mm]	I [mm]	M [mm]	P [mm]	Ajustement maximum [mm]	Poids [kg]
TV910 G1	345	135	189	130	65	10,5	44	188	151	100	78	6,1
TV910 G2	420	147	228	150	80	10,5	44	230	177	100	131	8,9
TV910 G3	475	170	267	185	108	12,5	55	269	222	123	171	14,5

GLISSIÈRES MOTEUR AJUSTABLES TB 911

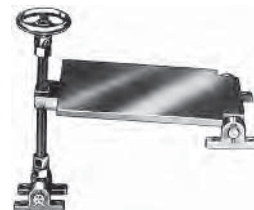

Description

Les glissières basculantes "TV 911", en fonte et acier, sont spécialement conçues pour des applications de variation de vitesse à poulies variables dans lesquelles le déplacement du moteur d'entraînement ne peut s'effectuer que par basculement en raison des impératifs de montage.

Ces glissières se composent d'une platine de fixation articulée en fonte et d'un système visécrou avec volant de manoeuvre également articulé en raison du basculement. L'ensemble est maintenu dans deux plans différents par des axes d'articulation et des double paliers largement dimensionnés afin de donner une grande rigidité au montage.

Le débattement prévu est suffisant pour obtenir la plage de variation désirée.

Ce type de glissière peut également être utilisé pour assurer la tension de courroies trapézoïdales entre un moteur électrique et une machine menée lorsque l'encombrement ne permet pas l'emploi de glissières classiques.

Désignation	TB	1
Glissières moteur TB911		
Type		

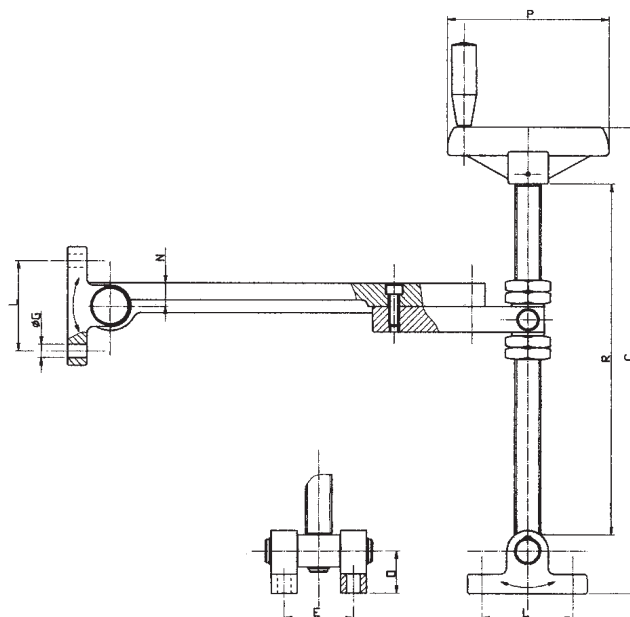
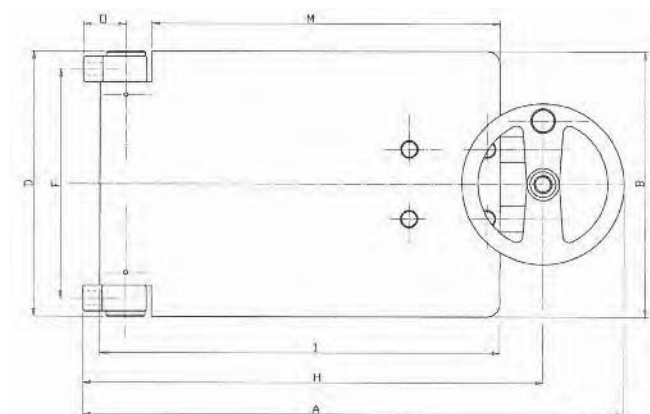

Type de glissière	A* [mm]	B [mm]	C [mm]	D [mm]	E [mm]	F [mm]	G [mm]	H* [mm]	I [mm]	L [mm]	M [mm]	N [mm]	O [mm]	P [mm]	R [mm]	Poids [kg]
TB 1	413	206	346	206	53	172	11	351	308	70	268	18	33	125	273	9,4
TB 2	548	316	520	315	58	280	11	486	436	70	391	22	36	125	443	20,0

* Avec un angle de 90 ° entre l'essieu moteur et le sol

Tension et alignement de la courroie



TEN-SIT® 2.0 - Contrôleur de tension Ten-Sit

TEN-SIT® 2.0 est une jauge électronique de courroie, utilisée pour la tension correcte de tous types de courroies. Son principe de fonctionnement repose sur la relation entre la tension de la

courroie et la fréquence de vibration de la courroie elle-même. **TEN-SIT® 2.0** est capable de mesurer avec précision la tension de toute courroie grâce à son microphone souple.

Désignation

MSTENSIT/02

TEN-SIT® 2.0 - Contrôleur de tension

Caractéristiques

- Fiabilité et précision
- Convient à tout type de courroie
- Pratique et polyvalent
- Léger et compact
- **Plage de sensibilité 8 ÷ 600 Hz**
- Microphone unidirectionnel

Mode d'emploi

Assurez-vous que l'entraînement est à l'arrêt. Vérifier que la sonde est connectée à la jauge. Appuyez sur la touche "ON" pour démarrer l'appareil. Placez la sonde aussi près que possible du dos de la courroie à mi-portée "L_f" sans la toucher lorsqu'elle vibre. Si cela n'était pas possible, à cause d'une protection, diriger la sonde vers la partie interne de la courroie. Faites vibrer la courroie en la frappant avec un marteau ou tout autre objet métallique.

Exemples de calculs

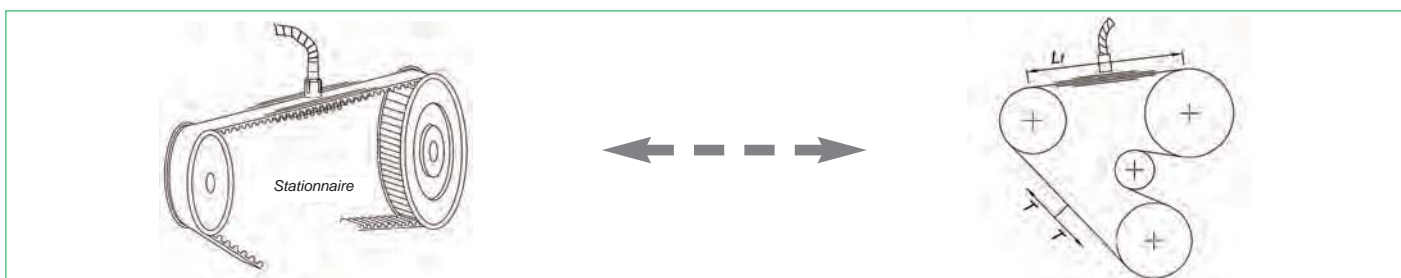

* Voir la table des masses linéaires

Courroie : 3150 HPPD PLUS 14M 55
Code SIT : HPPD3150P14M55

Masse linéaire : $(0,421/40) \cdot 55 = 0,579$ [kg/m] (Valeurs extraites de la table de masse)

Tension **T**: 2150 [N] (Valeur de traction T, avec entraînements stationnaires et poulies libres, constante sur toute la courroie)

Tolérance d'allongement de la courroie **L_f**: 0,65 [m]

La valeur de fréquence correcte qui doit être obtenue et lue sur le tensiomètre **TEN-SIT®** est:

Fréquence

$$f = \frac{1}{2 \cdot L_f} \sqrt{\frac{T}{M}} = \frac{1}{2 \cdot 0,65} \sqrt{\frac{2150}{0,579}} = 46,9 \text{ [Hz]}$$

Lisez la valeur de fréquence (Hz) sur l'écran une fois que le signal acoustique a été capté.

L'unité est capable de reconnaître et de différencier les vibrations de la courroie et le bruit de fond.

L'affichage indique alternativement la fréquence et le nombre de mesures effectuées si l'option entraînement à "plusieurs courroies" a été sélectionnée, mesurer alors chaque courroie individuellement et utiliser la valeur moyenne. Avec des courroies simples 2 ou 3 mesures doivent être prises pour garantir la précision.



Tension

$$T = 4 \cdot M \cdot L_f^2 \cdot f^2 = 4 \cdot 0,579 \cdot 0,65^2 \cdot 53^2 = 2749 \text{ [N]}$$

Masses linéaires des courroies

Type de courroie	Profil du pas [mm]	Largeur de la courroie [mm]	Masse linéaire [kg/m]
SIT Mustang Torque	8	20	0,083
	14	40	0,328
SIT Mustang Speed	5	9	0,031
	8	20	0,112
	14	40	0,408
SIT HPPD Plus HTD	3	9	0,022
	5	9	0,039
	8	20	0,115
	14	40	0,421
CLASSICA Imperial Pitch	XL	25,4	0,056
	L	25,4	0,082
	H	25,4	0,120
	XH	25,4	0,282
	XXH	25,4	0,406

Lorsque la largeur des courroies diffère de celles indiquées dans le tableau, faites un prorata de la largeur pour obtenir la valeur. Pour les banded, multiplier la valeur de masse par le nombre de rainures de la courroie.

Relation entre la tension de la courroie et la fréquence

$$T = 4 \cdot M \cdot L_f^2 \cdot f^2 \qquad f = \frac{1}{2 \cdot L_f} \sqrt{\frac{T}{M}}$$

Dans laquelle :

T = Tension statique de la courroie	[N]
M = Masse linéaire de la courroie	[kg/m]
L_f = Facteur d'élongation	[m]
f = Fréquence des vibrations	[Hz]

Masses linéaires des courroies trapézoïdales

Type de courroie	Profil du pas [mm]	Nombre de courroie	Masse linéaire [kg/m]
SIT TORQUE-FLEX "XP" (ISO)	XPZ	-	0,079
	XPA	-	0,110
	XPB	-	0,192
	XPC	-	0,310
SIT CLASSICAL V-BELTS TORQUE-FLEX (ISO)	ZX	-	0,053
	AX	-	0,100
	BX	-	0,158
	CX	-	0,251
SIT NARROW V-BELTS WEDGE - Envelope (RMA)	3V	-	0,078
	5V	-	0,236
	8V	-	0,531
SIT NARROW V-BELTS WEDGE Moulded Cog (RMA)	3VX	-	0,070
	5VX	-	0,192
SIT EXCELITE ES (ISO)	Z	-	0,059
	A	-	0,118
	B	-	0,197
	C	-	0,335
	D	-	0,630
SIT EXCELITE ES NARROW (ISO)	SPZ	-	0,059
	SPA	-	0,118
	SPB	-	0,197
	SPC	-	0,335
SIT BANDED V-BELTS NARROW (ISO)	SPZ	1	0,100
	SPA	1	0,132
	SPB	1	0,252
	SPC	1	0,433
SIT BANDED V-BELTS Classical (ISO)	BX	1	0,213
	CX	1	0,349
SIT NARROW BANDED V-BELTS WEDGE (RMA)	3V	1	0,118
	5V	1	0,283
	8V	1	0,705

En utilisant la formule, il est possible de calculer simplement la fréquence désirée pour toute transmission par courroie. Si la mesure indiquée est inférieure à la valeur calculée, la courroie nécessitera une tension supplémentaire. Si toutefois la mesure est supérieure à la valeur calculée, détendre le variateur. Dans les deux cas, mesurer à nouveau.

REMARQUE: Il est nécessaire de faire tourner le variateur sous charge pendant environ une ou deux minutes, puis d'utiliser le **TEN-SIT® 2.0** pour vérifier la valeur de la tension et le resserrer si nécessaire. Lorsque vous avez fini d'utiliser le tensiomètre **TEN-SIT® 2.0**, maintenez la touche "OFF" enfoncée jusqu'à ce que le triple signal acoustique soit entendu. Si "LOBAT" apparaît à l'écran, remplacez la pile.

LINE-LASER® - Outil d'alignement de poulies laser

Afin d'obtenir des performances et une durée de vie d'une transmission correcte, les poulies doivent être correctement alignées. Le **LINE-LASER®** est la solution idéale pour un alignement parfait et rapide.

Léger et fiable, il combine la précision de la technologie laser à l'utilisation facile.

Avantages

- Courroies, poulies et roulements prolongés
- Convient pour tous les types de poulies
- Réduction des vibrations
- Correction des désalignements axiaux et angulaires
- Faible frottement et économie de consommation d'énergie
- Trois références de contrôle

Caractéristiques

- Entraxe maximum autorisé : 2 mètres (plus que ce qui est nécessaire, mais la largeur du faisceau est ajoutée à l'erreur de pointage)
- Erreur maximale: 1 mm par mètre

Remarque:

L'appareil, par des chocs (par exemple, une chute accidentelle) pourrait perdre les alignements.

Vérifier périodiquement sur une surface de référence l'alignement de l'outil.



Alignement de la transmission

Les courroies synchrones sont très sensibles au désalignement. Les éléments porteurs de tension sont généralement tressés, multi-brins, de câbles en fibre de verre. Ils ont une résistance à la traction et à l'allongement élevée, ce qui produit une courroie très stable. Tout désalignement entraînera une usure inégale des courroies, une répartition irrégulière de la charge et une défaillance prématurée. En général, les courroies synchrones ne doivent pas être utilisées là où le désalignement est un problème. Le désalignement doit être limité à 1/4 ou 4,3 mm par mètre de distance centrale. Le désalignement peut être défini de deux manières. Tout d'abord, si deux poulies ne sont pas situées de manière égale sur les arbres, les poulies sont alors mal alignées, comme dans la Fig. 1. Deuxièmement, les arbres ne peuvent pas être parallèles, ce qui entraîne un désalignement, comme dans la Fig. 2.

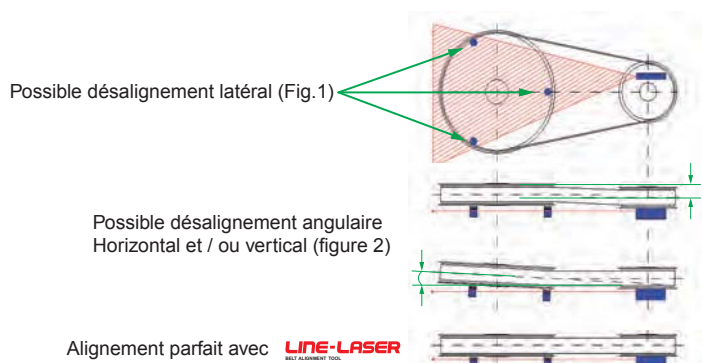

Désalignement

Tout degré de désalignement réduit la durée de vie de la courroie et entraîne une usure prématurée. Par conséquent, **LINE-LASER®** doit être utilisé pour vérifier l'alignement correct en vérifiant que les poulies et les arbres sont parallèles.

Le désalignement cause des problèmes d'entraînement. Les faces des poulies serviront à contrôler cet alignement pour un bon fonctionnement.

En considérant une transmission à deux poulies flasquées, le contact de courroie sur un seul bord est acceptable. Le contact de la courroie avec les flancs opposés de deux poulies doit être évité.

Alignement

Le mauvais alignement peut également être attribué à l'installation incorrecte d'une bague ou d'un châssis d'entraînement lâche. Reportez-vous aux instructions des fabricants des poulies pour une installation correcte des douilles. Fixez le moteur et le cadre pour éliminer les fluctuations vibratoires.

Stockage des courroies

Les courroies doivent être stockées à une température comprise entre 15 et 20 ° C, dans un endroit sec et propre. Elles doivent être stockées dans une position horizontale pour éviter les déformations.

Les courroies ne doivent jamais être pliées ou accrochées sur des pointes ou des crochets. Une longue exposition à la lumière directe du soleil et à la lumière peut endommager les courroies.



SIT S.p.A.
Viale A. Volta, 2
20090 Cusago (MI) - Italy
Tel. +39.02.89144.1
Fax +39.02.89144293
export@sitspa.it
www.sitspa.com

Usine
Via G. Carminati, 15
24012 Val Brembilla (BG) - Italy

SIT GERMANY

SIT ANTRIEBSELEMENTE GmbH
Rieseler Feld 9 (Gewerbegebiet West)
D - 33034 Brakel
Tel. +49.5272.3928.0
Fax. +49.5272.392890
E-mail: info@sit-antriebselemente.de

SIT SWITZERLAND

SIT (Schweiz) AG
Lenzbüel 13
CH - 8370 Sirmach
Tel. +41.71.969.50.00
Fax +41.71.969.50.01
E-mail: info@sit-antriebstechnik.ch

SIT SPAIN

DINAMICA DISTRIBUCIONES S.A.
Ctra. N-II, Km 592,6
E - 08740 S. Andreu De La Barca
(Barcellona)
Tel. +34.93.6533500
Fax. +34.93.6533508
E-mail: dinamica@dinamica.net

SIT FRANCE

FOGEX
215, Rue Henri Barbusse
F - 95103 Argenteuil Cedex
Tel. +33.01.34344600
Fax +33.01.34344601
E-mail: info@fogex.com

SIT USA

S.I.T. INDEVA, Inc.
3630 Green Park Circle
NC - 28217 Charlotte
Tel. 001.704.357.8811
Fax 001.704.357.8866
E-mail: info@sit-indeva.com

SIT CHINA

SIT INDEVA (SHANGHAI) LTD.
Building 2, 269 YuanZhong Road
Nanhui Industrial park
Pudong new area
PRC - 201300 Shanghai
Tel. +86.021.51082206
Fax +86.021.64863511
E-mail: info@sit-shanghai.com